

Cat. No. W204-E1-03



**SYSMAC BUS/2
CV-series**

Remote I/O

SYSTEM MANUAL

OMRON

SYSMAC BUS/2 Remote I/O

System Manual

Revised September 2002

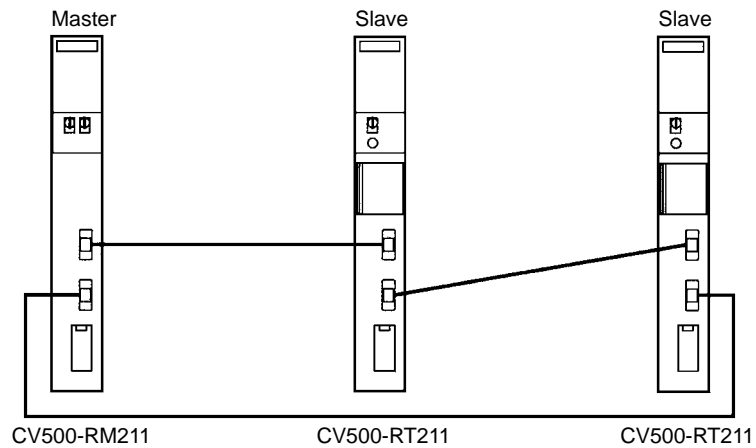
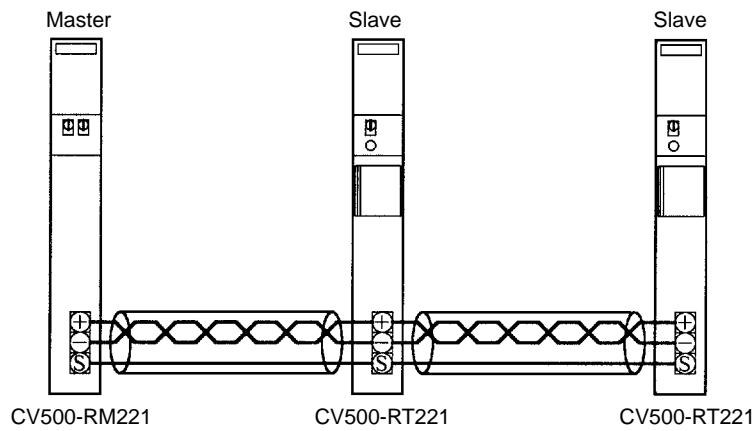

Notice:

OMRON products are manufactured for use according to proper procedures by a qualified operator and only for the purposes described in this manual.

The following conventions are used to indicate and classify warnings in this manual. Always heed the information provided with them.

Caution Indicates information that, if not heeded, could result in minor injury or damage to the product.

DANGER! Indicates information that, if not heeded, could result in loss of life or serious injury.

OMRON Product References

All OMRON products are capitalized in this manual. The word "Unit" is also capitalized when it refers to an OMRON product, regardless of whether or not it appears in the proper name of the product.

The abbreviation "Ch," which appears in some displays and on some OMRON products, often means "word" and is abbreviated "Wd" in documentation in this sense.

The abbreviation "PC" means Programmable Controller and is not used as an abbreviation for anything else.

Visual Aids

The following headings appear in the left column of the manual to help you locate different types of information.

Note Indicates information of particular interest for efficient and convenient operation of the product.

1, 2, 3... 1. Indicates lists of one sort or another, such as procedures, checklists, etc.

© OMRON, 1992

All rights reserved. No part of this publication may be reproduced, stored in a retrieval system, or transmitted, in any form, or by any means, mechanical, electronic, photocopying, recording, or otherwise, without the prior written permission of OMRON.

No patent liability is assumed with respect to the use of the information contained herein. Moreover, because OMRON is constantly striving to improve its high-quality products, the information contained in this manual is subject to change without notice. Every precaution has been taken in the preparation of this manual. Nevertheless, OMRON assumes no responsibility for errors or omissions. Neither is any liability assumed for damages resulting from the use of the information contained in this publication.

TABLE OF CONTENTS

SECTION 1

| | |
|-----------------------------------|----------|
| Introduction | 1 |
| 1-1 Outline of SYSMAC BUS/2 | 2 |
| 1-2 Features | 5 |
| 1-3 Terminology | 6 |

SECTION 2

| | |
|-----------------------------------|----------|
| System Configuration | 9 |
| 2-1 Overview | 10 |
| 2-2 System Limitations | 13 |
| 2-3 Transmission Paths | 18 |
| 2-4 Examples | 21 |

SECTION 3

| | |
|-----------------------------------|-----------|
| Installation | 25 |
| 3-1 Remote I/O Master Units | 26 |
| 3-2 Remote I/O Slave Units | 28 |
| 3-3 Wiring | 30 |

SECTION 4

| | |
|--|-----------|
| Switch Settings and Word Allocation | 37 |
| 4-1 Overview | 38 |
| 4-2 Word Allocation | 38 |
| 4-3 Other Switch Settings | 48 |
| 4-4 Unit Settings | 49 |

SECTION 5

| | |
|--|-----------|
| Operation | 53 |
| 5-1 Overview | 54 |
| 5-2 7-Segment Display | 54 |
| 5-3 CPU Bus Unit Area Operations | 57 |

SECTION 6

| | |
|-------------------------|-----------|
| I/O Delays | 69 |
|-------------------------|-----------|

SECTION 7

| | |
|---|-----------|
| Examples | 73 |
| 7-1 Remote I/O System Settings | 74 |
| 7-2 User Program for 7-Segment Display | 76 |
| 7-3 User Program for Stopping Slave Communications | 78 |
| 7-4 User Program for Stopping Master Communications | 79 |

SECTION 8

| | |
|--|------------|
| Troubleshooting | 81 |
| 8-1 Troubleshooting Flowcharts | 82 |
| 8-2 Troubleshooting with Indicators | 83 |
| 8-3 Troubleshooting from the CVSS | 88 |
| 8-4 Correcting Errors | 93 |
| 8-5 Transmission Path Backup | 97 |
| 8-6 Clearing Communications Errors | 101 |
| 8-7 I/O Table | 101 |
| Appendices | |
| A Standard Models | 107 |
| B Specifications | 111 |
| C CPU Bus Unit Area | 115 |
| D Auxiliary Area | 119 |
| E Settings for and Restrictions in Executing READ(190)/WRIT(191) | 123 |
| Glossary | 125 |
| Index | 141 |
| Revision History | 145 |

About this Manual:

This manual describes the installation and operation of the SYSMAC BUS/2 Remote I/O System and includes the sections described below. It covers general information on the System and specific information on the CV500-RM211 and CV500-RM221 Remote I/O Master Units and the CV500-RT211 and CV500-RT221 Remote I/O Slave Units. Specific information on other Slaves that can be connected to a SYSMAC BUS/2 Remote I/O System are available in operation manuals for the other Slaves.

Please read this manual completely and be sure you understand the information provide before attempting to install and operation a SYSMAC BUS/2 Remote I/O System.

Section 1 introduces the SYSMAC BUS/2 Remote I/O System, describes it's principle features, and defines terms that are used in the remainder of the manual.

Section 2 describes how various Units go together to create a Remote I/O System and provides the capabilities and limitations of the Systems. Examples showing various system configurations are also provided.

Section 3 describes the parts of the Remote I/O Master Units and Remote I/O Slave Units and tells how to mount and wire them. Technical specifications that are also need for actual wiring are provided in *Appendix B Specifications*.

Section 4 explains how words are allocated according to various settings and explains the other settings necessary to prepare a Remote I/O System. These settings include both hardware switch settings as well as software switch settings. A Peripheral Device (e.g., the CVSS) is required to make the software settings.

Section 5 describes various features that can be used to control operation once it has begun. User programming is required to use many of these features, so this section should also be read before installing the System and starting operation.

Section 6 describes calculations of the delay between receiving an input signal and producing an output signal in a Remote I/O System.

Section 7 provides examples of the steps to set up and program a System.

Section 8 provides procedures for debugging and troubleshooting a System. Included are flowcharts, indicator status explanations, and troubleshooting tables. The procedures to recover from errors and re-start the System are also provided in this section.

SECTION 1

Introduction

This section introduces Remote I/O Systems in general and outlines the SYSMAC BUS/2 Remote I/O System and its relation to other OMRON Systems. The main features of a SYSMAC BUS/2 System are also provided along with definitions of the basic terms and abbreviations used in this manual.

| | | |
|-------|---|---|
| 1-1 | Outline of SYSMAC BUS/2 | 2 |
| 1-1-1 | The SYSMAC BUS/2 Remote I/O System | 2 |
| 1-1-2 | SYSMAC BUS/2 in Relation to Other Systems | 3 |
| 1-2 | Features | 5 |
| 1-3 | Terminology | 6 |

1-1 Outline of SYSMAC BUS/2

1-1-1 The SYSMAC BUS/2 Remote I/O System

Programmable Controllers (PCs) have proven to be efficient, economical, and easy to maintain, and have made great contributions to productivity in terms of reducing costs and labor. With the growth in scale of production facilities, it became necessary to control and monitor a multitude of devices distributed in remote locations, and recent expectations for PC communications capabilities in a total FA and CIM environment have placed even greater burdens on PCs. To meet these challenges and to provide integrated control of remote I/O, OMRON first developed the SYSMAC BUS Remote I/O System. Now the CV-series introduces the SYSMAC BUS/2 Remote I/O System, which takes the basic features of SYSMAC BUS and adds advanced communications and maintenance capabilities.

SYSMAC BUS/2 is a remote I/O system that connects the PC to Slave Racks and other Slaves, such as I/O Terminals and Display Terminals. You can select either Wired and/or Optical Remote I/O Systems depending on your needs.

With SYSMAC BUS/2, remote Slaves can be controlled up to 500 m away for Wired Systems and up to 10 km (800 m between Racks) for Optical Systems.

Communications are executed through the Remote I/O Master Units mounted on the CPU or Expansion CPU Rack and the Slaves. A two cables connects the Units, thereby reducing wiring requirements. In addition, each Unit conducts communications automatically, and communications can be stopped in localized areas, so maintenance can be performed without affecting the overall system.

Communications with a SYSMAC LINK System or a SYSMAC NET Link System is made possible by the gateway function, which bridges different communications protocols. With a SYSMAC LINK System or SYSMAC NET Link System you can, for example, connect an FA computer in a central control room to integrate the production management, collection of production data, and monitoring of production conditions.

An illustration of the basic configuration of a Remote I/O System is shown below.

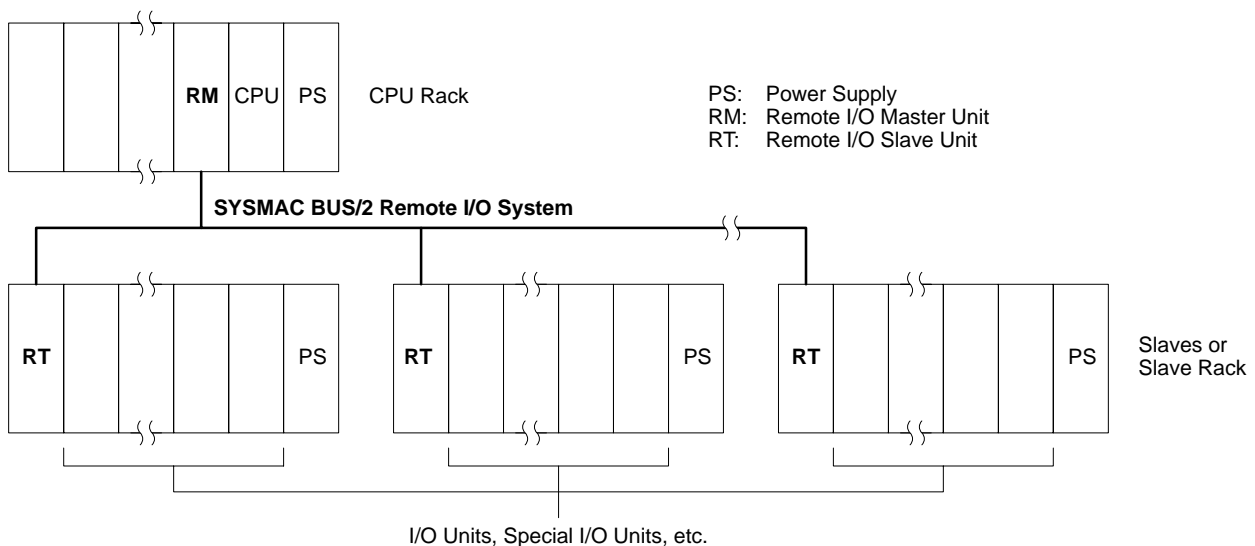

1-1-2 SYSMAC BUS/2 in Relation to Other Systems

The following illustration shows the relationship of the SYSMAC BUS/2 Remote I/O System to other OMRON Systems.

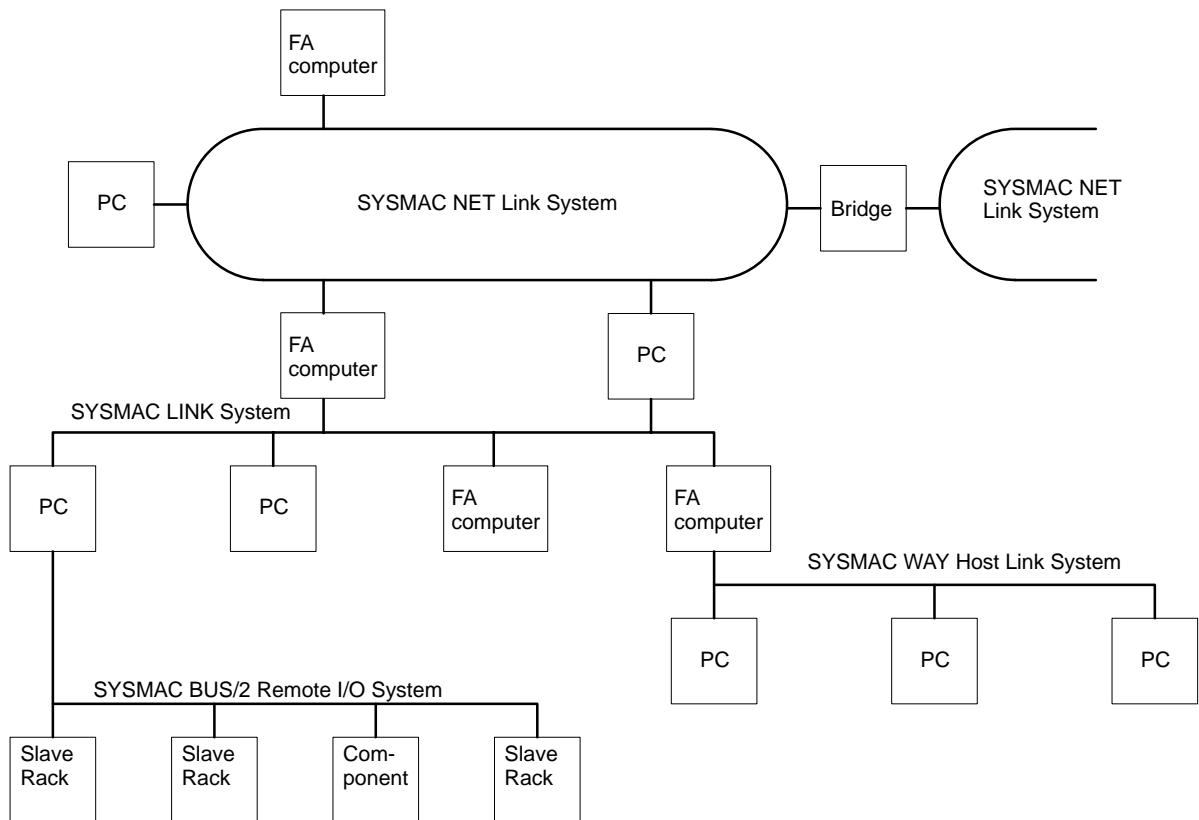

OMRON FA Network Systems

| System | Function | Communications | Baud rate | No. of nodes |
|--------------------------------|---|------------------------------|--|--------------------------------|
| SYSMAC NET Link System | Optical LAN (limited area network) for connecting differing models of personal computers and/or Programmable Controllers. | N:N, token ring | 2 Mbps | 127, including one line server |
| SYSMAC LINK System | A network for connecting PCs to each other or to an FA computer. | N:N, token bus | 2 Mbps | 62 |
| SYSMAC WAY Host Link System | A network for connecting to a host computer (a host link interface is built into CV-series PCs). | RS-232 (1:1) RS-422 (1:N) | 300, 600, 1200, 2400, 4800, 9600, or 19200 bps | 32 |
| SYSMAC BUS/2 Remote I/O System | A network connecting PCs, Slave Racks, and other Slaves to enable distributed control by a single PC of multiple I/O Units and Special I/O Units at remote locations. | 1:N, polling or selective | 1.5 Mbps | 32 (number of Slaves) |

Gateway

A gateway interfaces different communications protocols, e.g., between the SYSMAC BUS/2 and SYSMAC LINK or SYSMAC NET. The gateway capability provided in SYSMAC BUS/2 allows a Programming Device connected to the SYSMAC BUS/2 System to communicate with PCs or computers in a SYSMAC LINK System or a SYSMAC NET Link System. The flow of gateway data is as follows when going from a Slave Rack in a SYSMAC BUS/2 System to a PC in a SYSMAC LINK System:

- 1, 2, 3...**
1. Data input from a Programming Device is transmitted from the Slave to its Master via the SYSMAC BUS/2 System.
 2. The Master transmits the data to a SYSMAC LINK Unit located on the CPU (or Expansion CPU) Rack.
 3. The SYSMAC LINK Unit then transmits the data to the SYSMAC LINK network, through which the destination PC can access the data.

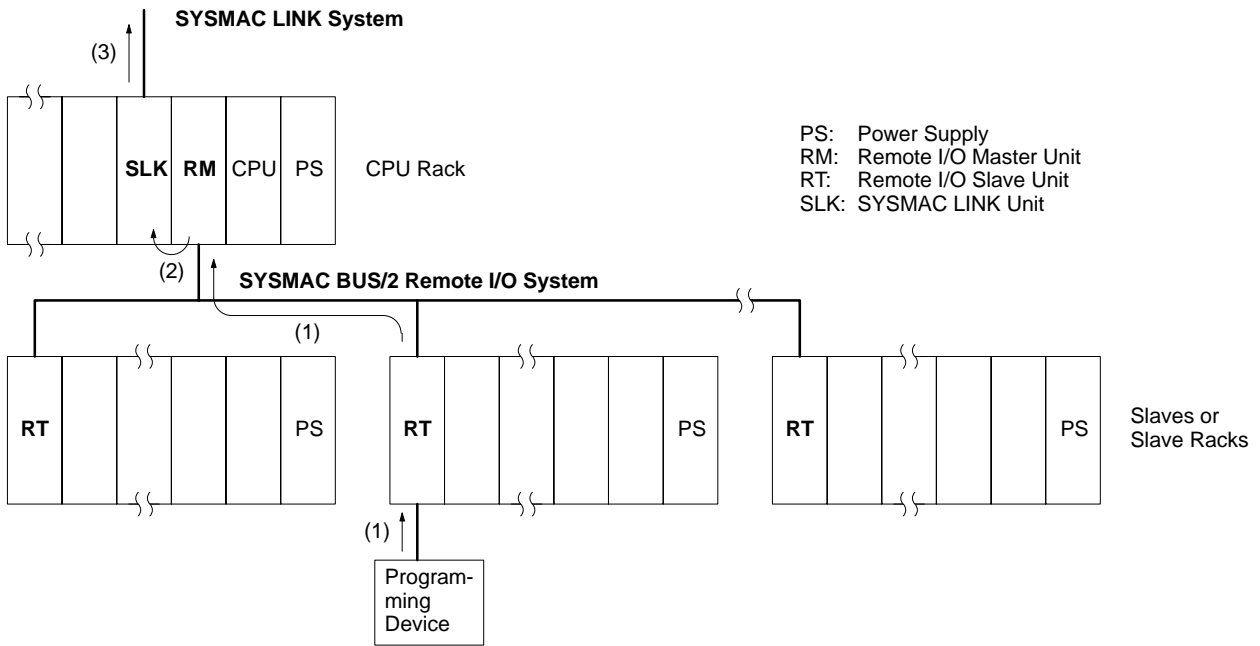

Communications Range

SYSMAC BUS/2 can communicate to devices located on networks up to two levels away (three, including the local SYSMAC BUS/2 network itself). For example, from the Programming Device connected to the Slave, you can access data in all the levels shown in the diagram below.

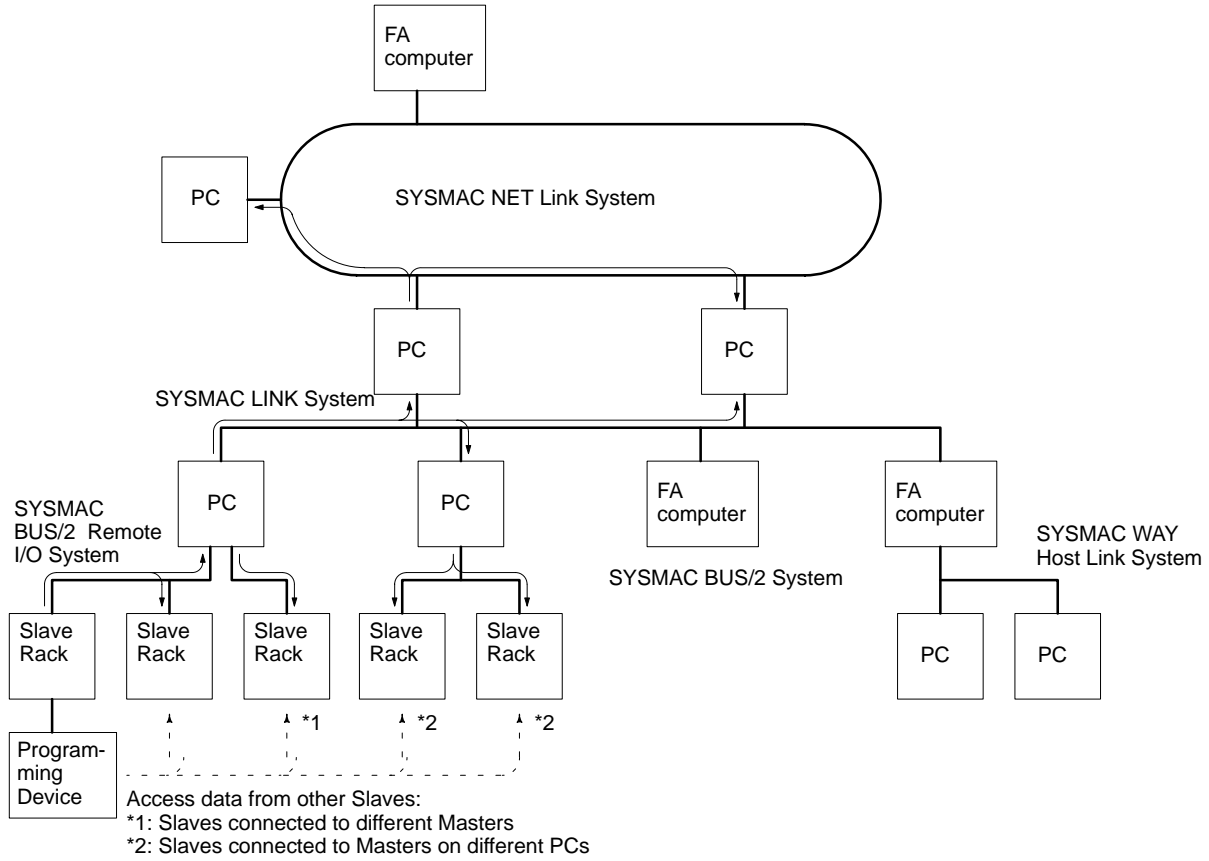

1-2 Features

Easy Distributed Control

Communication between Masters and Slaves is automatically handled by the Units themselves, thereby eliminating the need for special communications programs.

With the program in the PC's CPU, distributed control integrating multiple I/O Units and Special I/O Units is possible.

You can select either optical fiber cable (for optical systems) or twisted-pair cable (for wired systems).

Masters and Slaves can be connected by two-conductor cable (optical: two-core optical fiber; wire: twisted-pair cable), thereby greatly reducing installation requirements.

Versatile System Configuration

You can set up your system on a scale to meet your production needs. For large-scale systems, it is possible for the SYSMAC BUS/2 to communicate with SYSMAC LINK and SYSMAC NET. In addition, SYSMAC BUS/2 can be combined with the existing SYSMAC BUS Remote I/O System.

Gateway

A gateway interfaces different networks and enables communications with devices on SYSMAC WAY, SYSMAC LINK, and SYSMAC NET networks. This function gives you the advantages of high-speed communications without the need to worry about different protocols.

| | |
|----------------------------|---|
| Programming Devices | You can communicate with PCs connected to Masters and with other networks from a Programming Device connected to a Slave. |
| Communications | Cyclic and event communications at 1.5 M are supported. Cyclic data communications enable remote I/O refreshing. Event communications enable data manipulation with the DELIVER COMMAND instruction (CMND(194)) as well as remote monitoring and programming from Peripheral Devices. |

System Expandability and Flexibility

Units can be moved, changed, added, or replaced simply by stopping the section of the System involving them.

| | |
|------------------------------------|---|
| Stopping/Restarting Masters | Communications through a Master can be stopped to interrupt data transfer to the Slaves, thus enabling maintenance for that section of the Control System without stopping the entire System. Once maintenance has been completed, communications through the Master can be easily restarted. |
| Stopping/Restarting Slaves | Communications to individual Slaves can also be stopped and restarted. |
| Communications Tests | Communications tests are possible between a Master and individual Slaves in a Remote I/O System. |

Reliability and System Productivity

In FA systems it is essential to maximize reliability and speed. With SYSMAC BUS/2, optical transmission paths can be backed up by using optical fiber cable loops. In addition, errors can be quickly and accurately identified for rapid system recovery.

| | |
|---------------------------------|--|
| Transmission Path Backup | Optical fiber cables, which are not affected by noise, permit highly reliable and responsive communications. If a loop connection is used, the transmission path is switched automatically in the event of a breakdown in communications, thereby minimizing system down time. |
| Operating Status Readout | The operating status of Master is provided in the CPU Bus Unit Area. In addition, error flags and other error data are provided to facilitate the rapid identification of the problem area in the event of an error. |
| 7-Segment Displays | CV500 Slaves provide 4-digit, 7-segment displays to provide information on errors and operating conditions. |

Easy System Design

| | |
|---------------------------------|---|
| | You can set the communications cycle time and error detection standards. |
| Communication Cycle Time | You can set the communications cycle time between Masters and Slaves. |
| Operating Environment | You can set the detection standards for communications errors. In addition, you can select whether data is to be retained or cleared for each Slave for communications error. |

1-3 Terminology

The following terms are used in this manual. Although most of these are explained in detail later in the manual, they are offered here for convenience and to aid initial understanding.

Units and Racks

Units are sold as individual modules and include I/O Units, Special I/O Units, Link Units, CPU Bus Units, I/O Terminals, etc. When Units are mounted to a Backplane, they collectively form a Rack. The main Units and Racks that are directly related to Remote I/O Systems are described below.

| | |
|-------------------------------|--|
| Remote I/O Master Unit | The Unit through which a Remote I/O System is controlled and accessed. The Remote I/O Master Unit is mounted to the CPU Rack or Expansion CPU Rack |
|-------------------------------|--|

where it connects to the CPU bus. A Remote I/O Master Unit is called a Master for short and is classified as a CPU Bus Unit.

| | |
|------------------------------|---|
| Remote I/O Slave Unit | The Unit on a Slave Rack (see below) through which the I/O points on the Slave Rack are controlled or accessed. A Remote I/O Slave Unit is called a Slave for short. The term Slave is also used collectively to refer to all the Units that connect to the Remote I/O Master Unit, such as I/O Terminals, Programmable Terminals, and Optical I/O Units. |
| CPU Bus Units | A Unit that connects to the CPU bus on the CPU Rack or Expansion CPU Rack. CPU Bus Units include SYSMAC NET Link Units, SYSMAC LINK Units, SYSMAC BUS/2 Remote I/O Master Units, and BASIC Units. |
| Special I/O Units | Units dedicated to special purposes. Special I/O Units include a wide range of Units, such as Analog Input Units, Position Control Units, High-speed Counter Units, etc. |
| Peripheral Devices | Devices used to program the PC or to access and/or control data in PC memory areas. The main Peripheral Device for the CV-series PCs is the CV Support Software (CVSS) running on an IBM AT/PC or compatible. |
| CPU Rack | The Rack to which the CPU is mounted. The CPU Rack provides a CPU bus to which CPU Bus Units can be mounted. |
| Expansion CPU Rack | A Rack connected to the CPU Rack via the CPU bus and the I/O bus. CPU Bus Units can be mounted to an Expansion CPU Rack. |
| Expansion I/O Racks | Racks connected to the CPU Rack or Expansion CPU Rack through a I/O Interface Unit. Only the I/O bus is available on Expansion I/O Racks. |
| Slave Racks | Racks connected to the CPU Rack or Expansion CPU Rack through a Remote I/O Slave Unit. The Remote I/O Slave Unit is connected to a Remote I/O Master Unit on the CPU Rack or Expansion CPU Rack and provides slots for mounting I/O or Special I/O Units at remote locations. |

Numbers

Different Units are allocated different numbers to enable identification and to determine memory area word allocations.

| | |
|---------------------------|--|
| Unit Numbers | All CPU Bus Units are assigned unit numbers to identify them and allocate certain words in memory for special purposes. Slaves are also allocated unit number to allocate words to them. |
| Master Numbers | Although Masters have unit numbers assigned to them as CPU Bus Units, they also have their own numbers. These are automatically allocated in order according to the CPU bus unit numbers set for them. |
| Slave Unit Numbers | Slaves are also identified by numbers assigned to them. |

Slave Groups

Slaves are divided into three groups depending on the capabilities and requirements of the Units. Many of these Units have their own operation manuals. This manual deals mainly with the Remote I/O Slave Units, which are part of group 3.

| | |
|----------------|--|
| Group 1 | Includes Slaves of type 1Q, 2Q, 1I, 2I, 2M, and 4M. |
| Group 2 | Includes Slaves of type 4Q, 8Q, 4I, 8I, 8M, 16M, 4MH, and 0NH. |
| Group 3 | Includes Slaves of type 58M, 54MH, and 122M. |

Abbreviations

| | |
|--------------|----------------------------------|
| RM | Remote I/O Master Unit |
| RT | Remote I/O Slave Unit |
| G1 | Group-1 Slaves |
| G2 | Group-2 Slaves |
| G3 | Group-3 Slaves |
| IOIF | I/O Interface Unit |
| IOC | I/O Control Unit |
| PS | Power Supply |
| SNT | SYSMAC NET Link Unit |
| SLK | SYSMAC LINK Unit |
| # | Used to identify unit numbers. |
| & | Used to identify master numbers. |

SECTION 2

System Configuration

This section describes the way in which a Remote I/O System is constructed and the Units that can be included. It also provides the limits placed on System size for each aspect of the system and illustrates four examples Systems composed of various parts. Details on actually mounting and connecting Remote I/O Systems are provided in *Section 3 Installation* and details on setting switches and other preparations for operation are provided in *Section 4 Switch Settings and Word Allocation*.

| | | |
|-------|---|----|
| 2-1 | Overview | 10 |
| 2-1-1 | Slaves | 11 |
| 2-1-2 | Link Units | 11 |
| 2-1-3 | Racks | 12 |
| 2-1-4 | Limitations | 12 |
| 2-1-5 | Communications | 13 |
| 2-1-6 | Programming Devices | 13 |
| 2-2 | System Limitations | 13 |
| 2-2-1 | Remote I/O Master Units | 13 |
| 2-2-2 | Slaves | 14 |
| 2-2-3 | Restrictions on Other Units | 16 |
| 2-2-4 | Restrictions on Programming Devices | 16 |
| 2-2-5 | I/O Points | 17 |
| 2-3 | Transmission Paths | 18 |
| 2-4 | Examples | 21 |
| 2-4-1 | CPU Rack | 21 |
| 2-4-2 | Expansion Racks | 22 |
| 2-4-3 | Special I/O Units | 23 |
| 2-4-4 | Peripheral Devices | 24 |

2-1 Overview

The following illustration shows the basic system configuration of a PC that includes a SYSMAC BUS/2 Remote I/O System. The System shown below includes three Remote I/O Subsystems, each of which starts with one Remote I/O Master Unit. Each Master is in turn connected to a series of Slaves that form the Remote I/O System. Each of the three Remote I/O Subsystems is outlined with broken lines.

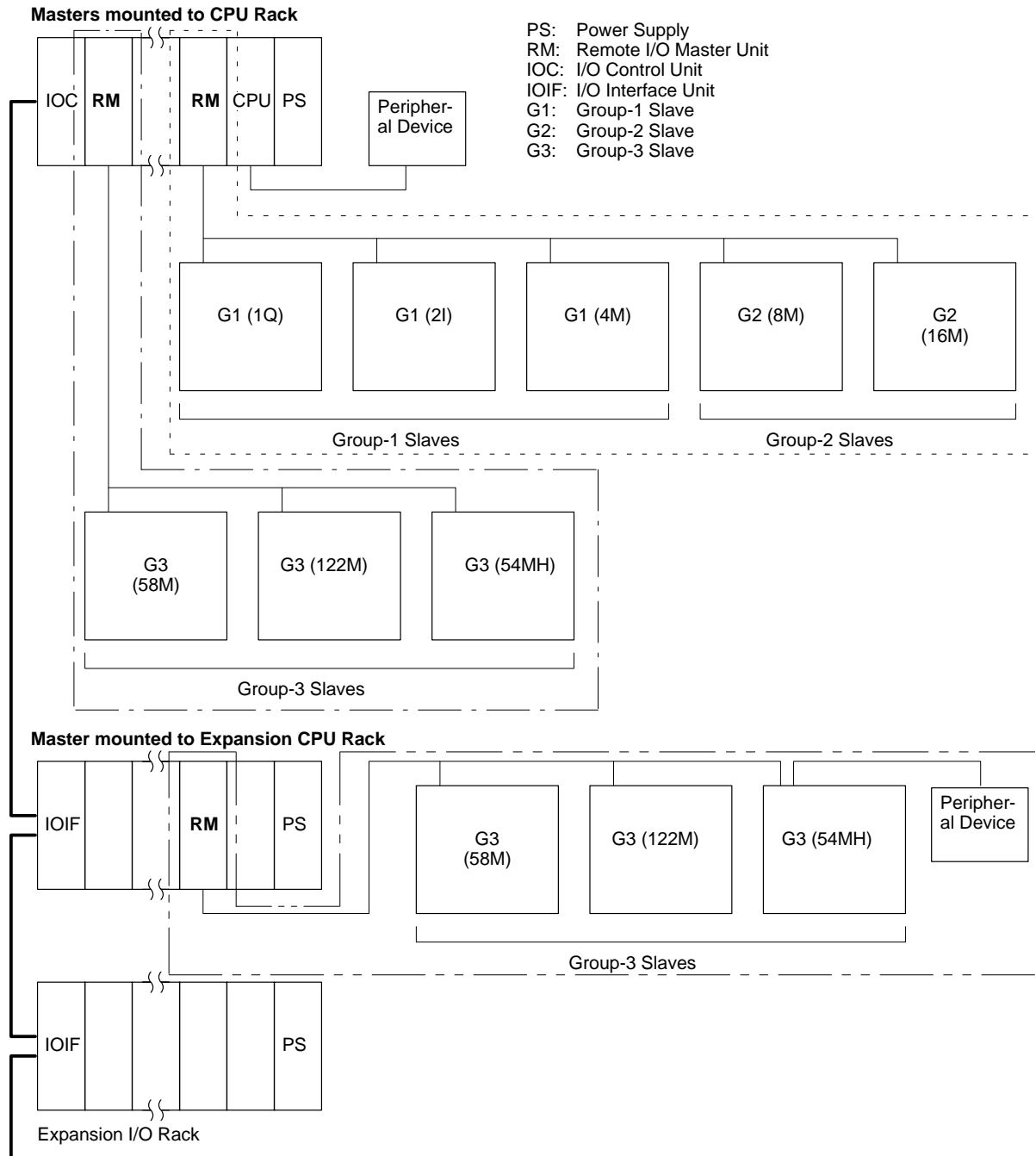

The remainder of this section introduces the basic components of a Remote I/O System and other Units related to Remote I/O Systems in general.

2-1-1 Slaves

There are various types of Slave that can be connected to a Remote I/O Master Unit. These Slaves include I/O Terminals, Programmable Displays, and Remote I/O Slave Units.

Slaves are classified into various types by the number of I/O they provide and by the special features that they offer. The numbers in type designations indicate the total number of I/O words available for that Unit (one word = 16 bits). The letters indicate the following:

- Q: Output only
- I: Input only
- M: Mixed (input and output)
- H: Group 2: Event communications possible
Group 3: Special I/O Units connectable

The number of input bits available is independent of the number of output bits available. For example, the 58M has 29 input and 29 output words, for a total of 58 words. Even if fewer than 29 input words are used it will not increase the number of output words available

There are two types of event communications possible: those using the DELIVER COMMAND instruction (CMND(194)) from the PC user program and those executed from Programming Devices, such as the CVSS.

CV500-RT211 and CV500-RT221 Remote I/O Slave Units are classified as Group-3 Slaves and are used for form Slave Racks. They can be switched between the three group-3 Slave types by setting a DIP switch.

| Name | Type | Output points | Input points | Communications |
|---------------------|------|---------------|---------------|--|
| Group-1 Slaves (G1) | 1Q | 16 | 0 | Not possible |
| | 2Q | 32 | 0 | |
| | 1I | 0 | 16 | |
| | 2I | 0 | 32 | |
| | 2M | 16 | 16 | |
| | 4M | 32 | 32 | |
| Group-2 Slaves (G2) | 4Q | 64 | 0 | Not possible |
| | 8Q | 128 | 0 | |
| | 4I | 0 | 64 | |
| | 8I | 0 | 128 | |
| | 8M | 64 | 64 | |
| | 16M | 128 | 128 | |
| | 4MH | 32 | 32 | Possible |
| Group-3 Slaves (G3) | 58M | 29 words max. | 29 words max. | Possible for CV500-RT211/RT221 only. |
| | 54M | 27 words max. | 27 words max. | |
| | 122M | 61 words max. | 61 words max. | |

2-1-2 Link Units

The Units in the following table are classified as Link Units. Link Units enable communications between different PCs, between PCs and other devices on networks including the PC, or between remote I/O and the CPU. With the exception of Remote I/O Slave Units, the Units listed in the following table are also classified as CPU Bus Units because they mount to the CPU bus, through which they are able to communicate with the CPU.

Although SYSMAC NET Link and SYSMAC LINK Units are not directly a part of a Remote I/O System, they are directly related because they can be included in a System to enable communications from Slaves, through the PC, and to other PCs connected to via SYSMAC NET Link and SYSMAC LINK Units.

| Unit | Types | Purpose |
|------------------------|---|--|
| Remote I/O Master Unit | Optical: CV500-RM211 Wired: CV500-RM221 | To connect to a CPU Rack or an Expansion CPU Rack to Slaves to create a SYSMAC BUS/2 Remote I/O System. |
| Remote I/O Slaves | Group-1 Slaves Group-2 Slaves Group-3 Slaves Slave Racks Optical: CV500-RT211 Wired: CV500-RT221 | To connect a Master to other Units so that the CPU can communicate with these Units via the SYSMAC BUS/2 Remote I/O System. The Remote I/O Slave Units (CV500-RT211 and CV500-RT221) are used to create Slave Racks |
| SYSMAC NET Link Unit | CV500-SNT31 | To connect the PC to SYSMAC NET Link System. A SYSMAC NET Link System is a LAN (limited area network) that can be composed of both PC and non-PC nodes. SYSMAC NET Link Systems enable communications and automatic data exchange. |
| SYSMAC LINK Unit | Optical: CV500-SLK11 Wired: CV500-SLK21 | To connect the PC to other PCs in a SYSMAC LINK System to enable communications and automatic data exchange. |

2-1-3 Racks

| Rack | Purpose | Remarks |
|---------------------|---|--|
| CPU Rack | Controls I/O and data processing. The CPU Rack also provides a CPU bus to which CPU Bus Units can be mounted. | CV500/CV1000/ CV2000/CVM1 CPU Units |
| Expansion CPU Rack | Provides slots for mounting additional CPU Bus Units and other Units. An Expansion CPU Rack connects to the CPU Rack via the CPU bus and I/O bus through of an I/O Interface Unit (CV500-II101). | — |
| Expansion I/O Racks | Connect to a CPU Rack or Expansion CPU Rack through of an I/O Interface Unit (CV500-II201) to provide additional slots for Special I/O Units and I/O Units. CPU Bus Units cannot be mounted to Expansion I/O Racks. | — |
| Slave Racks | Allow I/O and Special I/O Units to be placed in remote locations. A Slave Rack (a group-3 Slave) is connected to the CPU Rack or Expansion CPU Rack via a Master and provides slots for mounting I/O and Special I/O Units. | Group-3 Slaves |

2-1-4 Limitations

PC

The following table shows the maximum number of actual I/O, Masters, Expansion I/O Racks, and CPU Bus Units support by each PC.

| PC | Total I/O points | Masters | Expansion I/O Racks* | CPU Bus Units* |
|--------------------------------|--|---------|----------------------|----------------|
| CV500/ CVM1-CPU01-E | Local I/O only: 512 Local and remote I/O: 1,536 | 2 max. | 7 max. | 16 max. |
| CV1000/CV2000/ CVM1-CPU11-E | Local I/O only: 1,024 Local and remote I/O: 3,072 | 4 max. | 7 max. | 16 max. |

Note * CVM1-BC103/053 Backplanes do not support Expansion CPU Racks and support only one Expansion I/O Rack. They thus support a maximum of 3 or 6 CPU Bus Units, depending on the CPU Backplane used.

Remote I/O Master Units

The following table shows the maximum number of Slaves and Programming Devices supported by each Master. Refer to 2-2-2 *Slaves* for details on computing the number of group-3 Slaves allowed for each Master.

Programming Devices can be connected to the CV500-RT211/RT221 only.

| Master | Slaves | | | Programming Devices |
|---|---------|---------|--|---------------------|
| | Group 1 | Group 2 | Group 3 | |
| CV500-RM211 (Optical) CV500-RM221 (Wire) | 32 | 16 | 8 (counting 58M Slaves as 1 each and 54MH and 122M Slaves as 2 each) | 2 |

2-1-5 Communications

Masters and Slaves I/O data transfer is automatically controlled between Masters and Slaves, so there is no need for a special communications control program.

Special I/O Units Most Special I/O Units can be mounted to SYSMAC BUS/2 Slave Racks for special remote control needs. The I/O READ/WRITE instructions can be used for these remote Special I/O Units, however, only for more recent product versions. Refer to *Compatible Special I/O Units in Appendix A Standard Models* for details.

Programming Devices Connecting Programming Devices to Remote I/O Slave Units on Slave Racks enables programming, data changes, and monitoring across two network levels (three including the Remote I/O System) and simplifies maintenance.

2-1-6 Programming Devices

The CV Support Software (CVSS) or other CV-series Programming Device can be connected to the CV500-RT211/RT221 to enable communications with the PC's CPU. The following features are provided.

CVSS:

- PC programming and debugging
- Monitoring I/O, timers, counters, word contents, etc.

Graphic Programming Console (GPC):

- PC monitoring, debugging, and ladder-diagram programming
- (Does not support SFC programming)

Programming Console:

- PC monitoring and ladder-diagram programming
- (Does not support SFC programming and other advanced programming/debugging operations)

Up to two Programming Devices can be connected for each Master and up to four can be connected for each PC, including those connected to the CPU and Expansion CPU Racks. If these numbers are exceeded, it may result in a communications error and faulty operation.

2-2 System Limitations

2-2-1 Remote I/O Master Units

Number Connectable The maximum number of Masters that can be mounted to a single PC (including both the CPU Rack and Expansion CPU Rack) is two in a CV500 or CVM1-CPU01-E System and four in a CV1000, CV2000, or CVM1-CPU11-E System. These limits include all Masters, regardless of whether they are wired or optical.

| PC | Number of Masters |
|----------------------------|-------------------|
| CV500/CVM1-CPU01-E | 2 |
| CV1000/CV2000/CVM1-CPU11-E | 4 |

Mounting Location Masters can be mounted to any slot on the CV500-BC101/051/031 CPU or CV500-BI111 Expansion CPU Backplane except for these reserved for other Units. Masters cannot be mounted to Expansion I/O Racks.

Masters can be mounted to only certain slots on CVM1-BC103/053 CPU Backplanes.

CPU Rack

On a CV500-BC101/051/031 CPU Rack, a Master can be mounted in any of the 10/5/3 slots shown in the following illustration. It cannot be mounted in the leftmost slot even if an Expansion CPU Rack or Expansion I/O Rack is not connected.

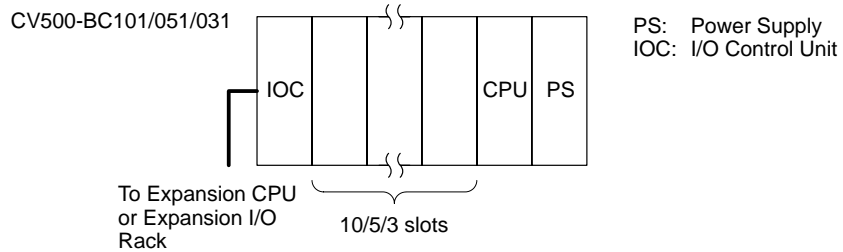

Masters can also be mounted to any of the rightmost 6 slots on the CVM1-BC103 CPU Backplane or any of the rightmost 3 slots on the CVM1-BC053 CPU Backplane.

Expansion CPU Rack

On an Expansion CPU Rack, a Master can be mounted in any of the 11 slots shown in the following illustration.

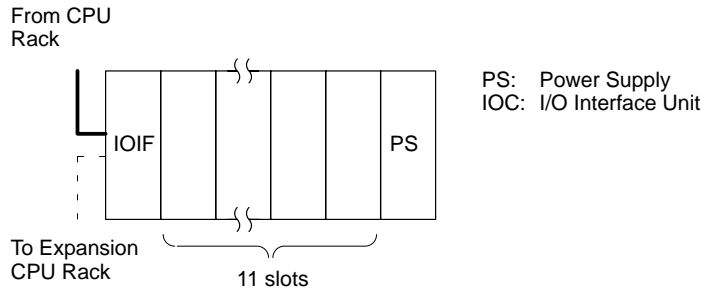

2-2-2 Slaves

Limitations

The following table shows the maximum number of Slaves that can be connected to each Master for each group of Slaves.

| Master | Slave group | | |
|--|-------------|----|--|
| | 1 | 2 | 3 |
| CV500-RM211 (Optical) CV500-RM221 (Wired) | 32 | 16 | 8 (counting 58M Slaves as 1 each and 54MH and 122M Slaves as 2 each) |

Group-1 Slaves

A maximum of 32 group-1 Slaves can be connected to a single Master.

Group-2 Slaves

A maximum of 16 group-2 Slaves can be connected to a single Master.

Group-3 Slaves

Group-3 Slaves include three types: 58M, 54MH, and 122M. The CV500-RT211 and CV500-RT221 (Group-3 Slaves) can be set to 58M, 54M, or 122M with a DIP switch setting. This setting determines the total number of remote I/O points possible on the Slave Rack. The total of all Group-3 Slaves must be consider if a Slave of more than one type is connected.

When calculating the total allowable number of Slaves, each 122M or 54HM Slave counts as two 58M Slaves. If various types of Slave are used together, add up the total number of Slaves, counting 122M and 54HM Slaves as 2 each and 58M Slaves as 1 each. The total must be less than 8.

For example, if three 122M Slaves and two 58M Slaves were connected, each of the 122M Slaves counts as two 58M Slaves, so the total number of group-3 Slaves would be computed as follows:

$$\begin{aligned} &(122M) \quad (58M) \\ &(3 \times 2) + (2 \times 1) = 8 \end{aligned}$$

This combination would be the equivalent of eight group-3 Slaves and the System would operate properly.

Note If the number of Units actually connected does not agree with those registered in the I/O table in the CPU, then the System will not operate properly even if the limit to the number of Slaves is not exceeded.

Example

The following System includes one Master, six 58M Slaves, and one 122M Slave. The total number of group-3 Slaves can thus be calculated as follows:

$$1 + 2 + 1 + 1 + 1 + 1 = 8$$

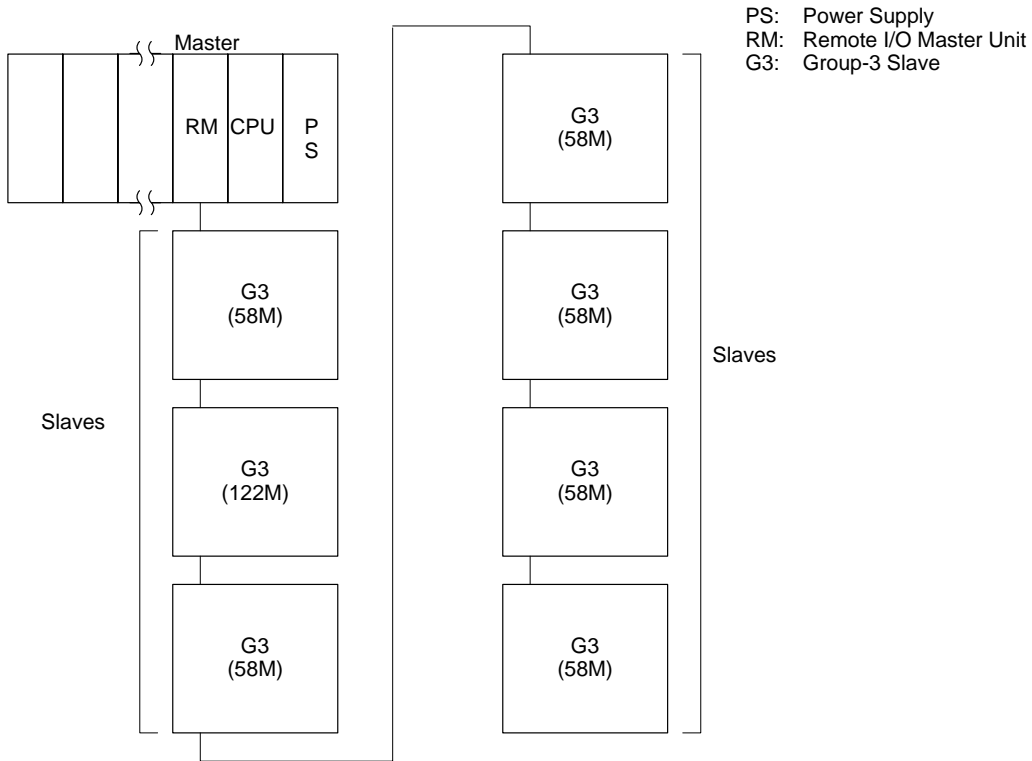

Slave Racks

Mounting Location

The CV500-RT211 or CV500-RT221 must be mounted to the leftmost slot of a CV500-BI112 Backplane to create a Slave Rack.

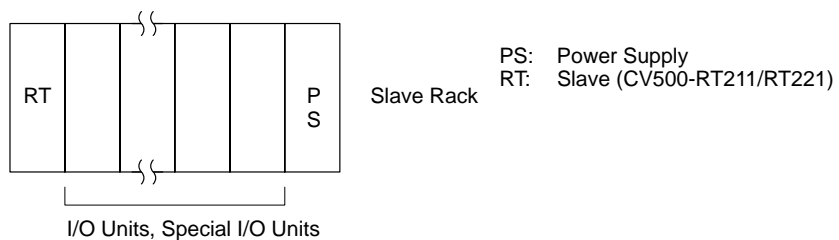

Unit Limitations

The following table shows the number of I/O Units and Special I/O Units that can be mounted to each Slave Rack (group-3 Slave).

| Type of Slave | Units per Slave | |
|---------------------|-----------------|-------------------|
| | I/O Units | Special I/O Units |
| 58M 54MH 122M | 11 max. | 8 max. |

The I/O READ/WRITE instructions (READ(190) and WRIT(191)) can be used for Special I/O Units on Slave Racks only under certain conditions. For details on the types and models of Special I/O Units that can be used and the conditions for using READ(190) and WRIT(191), refer to *Appendix A Standard Models*.

Terminator Settings

In Wired Remote I/O Systems, the Slave at the end of the transmission path must be set as the terminator. There must be one and only one terminator set for each Master. If there is no terminator set or if there are two or more terminators set, the SYSMAC BUS/2 System will not operate. For details, refer to *4-3 Other Switch Settings*.

2-2-3 Restrictions on Other Units**CPU Bus Units**

SYSMAC BUS/2 Masters are classified as CPU Bus Units. A maximum of 16 CPU Bus Units can be mounted to one PC (including both the CPU Rack and the Expansion CPU Rack).

Special I/O Units

Most Special I/O Units can be connected to Slave Racks in a SYSMAC BUS/2 System, but the I/O READ/WRITE instructions (READ(190) and WRIT(191)) can be used for Special I/O Units on Slave Racks only under certain conditions. For details on the types and models of Special I/O Units that can be used and the conditions for using READ(190) and WRITE(191), refer to *Appendix A Standard Models*.

2-2-4 Restrictions on Programming Devices**Number Connectable**

Only one Programming Device can be connected to a single Slave and can be connected only to the CV500-RT211/RT221. In addition, only two Programming Devices can be connected for each Master. If multiple Masters are mounted to a single PC, then a total of four Programming Devices can be connected, including any connected to the CPU.

Available Devices

The Programming Devices that can be used with the SYSMAC BUS/2 System are the CVSS, the CV-series Programming Console, and the CV-series GPC.

Connecting Cable

For connecting Programming Devices to Slaves, use special-purpose CVSS cables.

Note Set the baud rate for communicating between a Programming Device and a Slave with a DIP switch setting on the Slave. For details, refer to *4-3 Other Switch Settings*.

2-2-5 I/O Points

Total I/O Points

There is a limit to the number of I/O points that the CPU can process. The maximum number of I/O points that can be processed on local Racks (i.e., CPU Racks, Expansion CPU Racks, and Expansion I/O Racks) is 512 for the CV500/CVM1-CPU01-E and 1,024 for the CV1000/CV2000/CVM1-CPU11-E. In addition, if CV-series Masters are mounted, the number of bits that can be used by Remote I/O Units is 1,024 for the CV500/CVM1-CPU01-E and 2,048 for the CV1000/CV2000/CVM1-CPU11-E. In addition, the number of I/O points that can be used by a SYSMAC BUS Remote I/O System is 512 for the CV500/CVM1-CPU01-E and 1024 for the CV1000/CV2000/CVM1-CPU11-E.

| PC | Maximum number of I/O points | | | |
|--------------------------------|------------------------------|--------------|------------|-------|
| | Local Racks | SYSMAC BUS/2 | SYSMAC BUS | Total |
| CV500/ CVM1-CPU01-E | 512 | 1,024 | 512 | 2,048 |
| CV1000/CV2000/ CVM1-CPU11-E | 1,024 | 2,048 | 1,024 | 4,096 |

Remote I/O Points

The total number of I/O points for a SYSMAC BUS/2 System is the sum of all the I/O points connected to all the Masters mounted to the PC. In order for the System to operate properly, the following three conditions must be satisfied:

- 1, 2, 3... 1. The sum total of I/O points for Units mounted to CPU Racks, Expansion CPU Racks, and Expansion I/O Racks must not exceed 512 for the CV500/CVM1-CPU01-E and 1,024 for the CV1000/CV2000/CVM1-CPU11-E. Remote I/O Master Units are ignored when computing this total.
2. The total number of I/O points in the SYSMAC BUS/2 System must not exceed 1,024 for the CV500/CVM1-CPU01-E and 2,048 for the CV1000/CV2000/CVM1-CPU11-E regardless of the number of Masters being used. This total includes all Units mounted to Slave Racks and all other Units connected through a Master.
3. The total number of I/O points in the SYSMAC BUS System must not exceed 512 for the CV500/CVM1-CPU01-E and 1,024 for the CV1000/CV2000/CVM1-CPU11-E regardless of the number of Masters being used. This total includes all Units mounted to Slave Racks and all other Units connected through a Master.

Example

In this example, the CPU Rack is a CV500, and the Masters, Slaves, and Expansion CPU Rack are connected as shown in the following illustration.

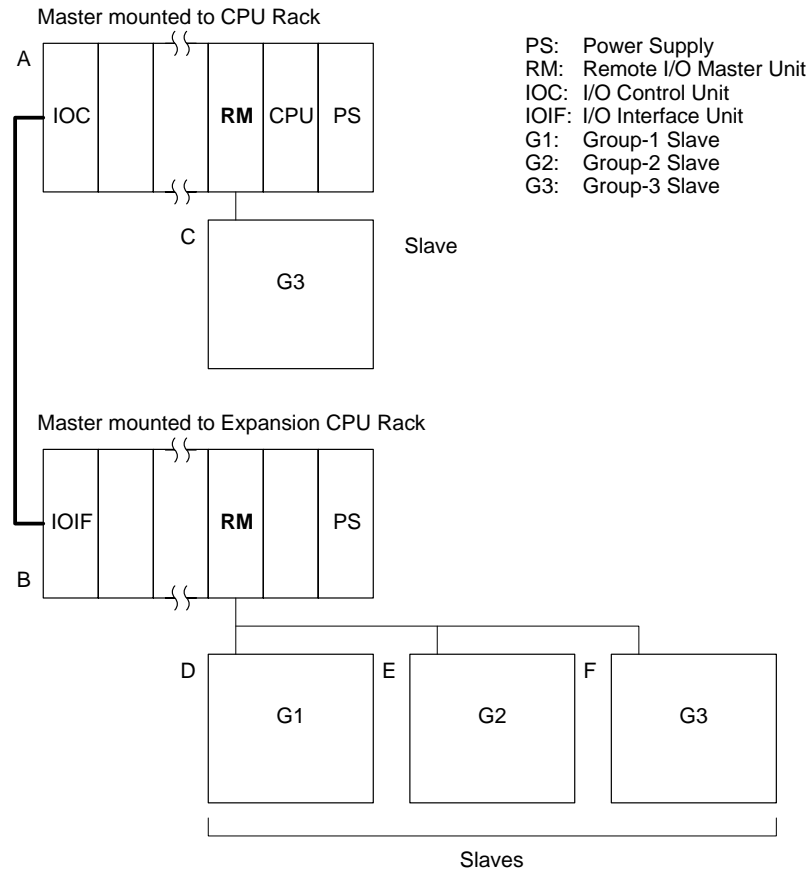

A total of up to 512 I/O points can be provided on the CPU Rack (A) and Expansion CPU Rack (B) and a total of 1,024 points can be provided by Slaves C, D, E, and F.

$$\text{Number of I/O points on A} + \text{B} \leq 512$$

$$\text{Number of I/O points for C} + \text{D} + \text{E} + \text{F} \leq 1,024$$

2-3 Transmission Paths

Each Master is connected to the Slaves using shielded twisted-pair cable for Wired Units and optical fiber cable for Optical Units. For general guidelines, refer to the following table. For model numbers and other details, refer to *Appendix A Standard Models*.

| Units | Cable | Features | Notes |
|---------|-----------------------|---|---|
| Wired | Shielded twisted-pair | Low cost Simple wiring | More susceptible to noise than optical. |
| Optical | Optical fiber (H-PCF) | Not susceptible to noise. Long-distance transmission | --- |

- Note**
1. Optical and Wired Remote I/O Units cannot be combined within a single Remote I/O Subsystem. Optical Masters can thus be connected only to Optical Remote I/O Slave Units, Optical I/O Units, and I/O Link Units, while Wired Masters can thus be connected only to Wired Remote I/O Slave Units, Wired I/O Units, and I/O Terminals. Both Optical Masters and Wired Masters can be mounted to the same PC.
 2. Grounds must be connected for Programming Devices in Wired Systems.

Wired Systems

The maximum total length of a Wired System is 500 m. CV500-RT-221 Slaves are shown in the following example. Wired Systems use multidrop connections; connect plus to plus, minus to minus, and S to S. Set the last Slave as the terminator. Refer to 4-3 Other Switch Settings and 3-3 Wiring for details on switch settings and wiring.

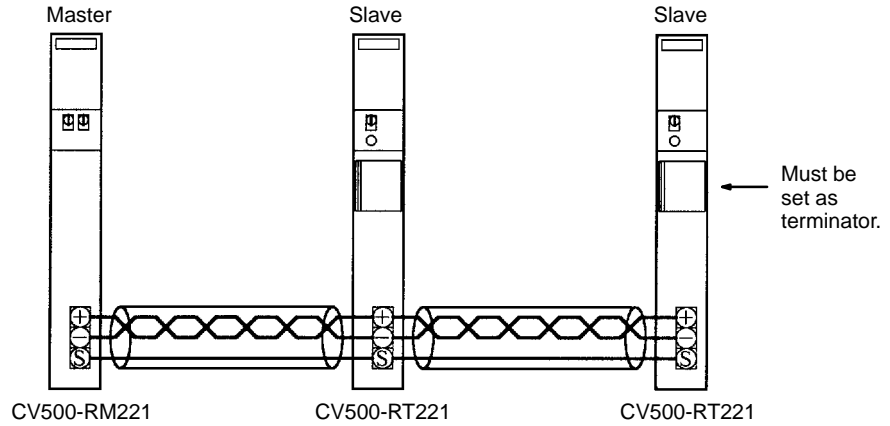

Optical Systems

The maximum distance between Units in an Optical System is 800 m. CV500-RT-211 Slaves are shown below. On CV500-RT211 Slaves there is no difference between the upper and lower optical connectors. Refer to 3-3 Wiring for details on connecting Slaves.

Optical Systems can be connected either in daisy-chain fashion or in a loop. Loop connections provide a transmission path backup.

Daisy Chains

Daisy chains can be made using either normal or sub-line connections.

Normal Line Connections

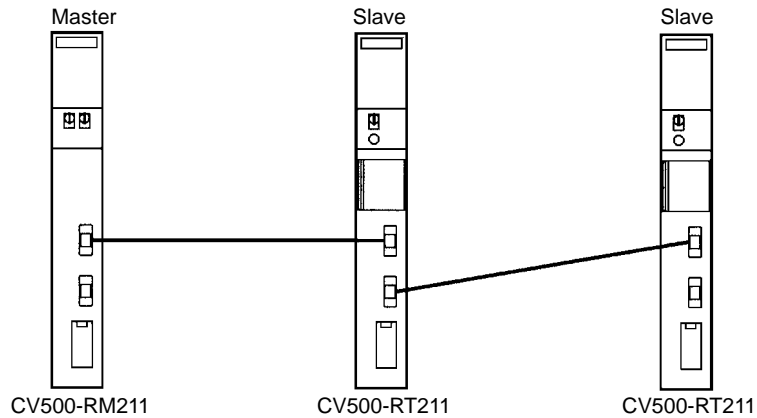

Sub-line Connections

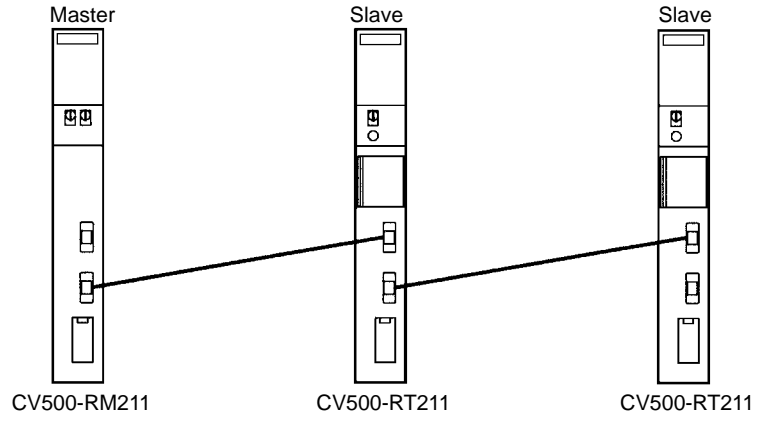

Loops

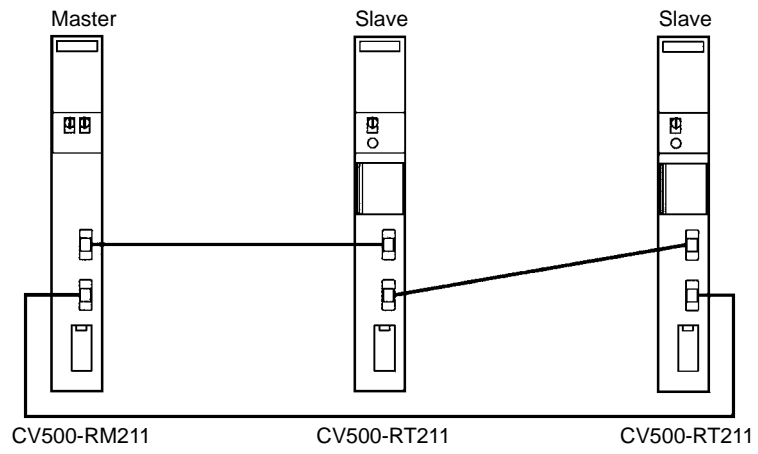

2-4 Examples

The following examples show various examples of system configurations and the limits for each.

2-4-1 CPU Rack

System Limitations

| | |
|----------------------------------|--|
| CPU Rack: | CV500, CV1000, CV2000, CVM1 |
| Number of Masters: | CV500/CVM1-CPU01-E: 2 max. CV1000/CV2000/CVM1-CPU11-E: 4 max. |
| Number of I/O Points for Slaves: | CV500/CVM1-CPU01-E: 1,024 max. CV1000/CV2000/CVM1-CPU11-E: 2,048 max. |
| Number of Slaves: | Refer to page 14. |

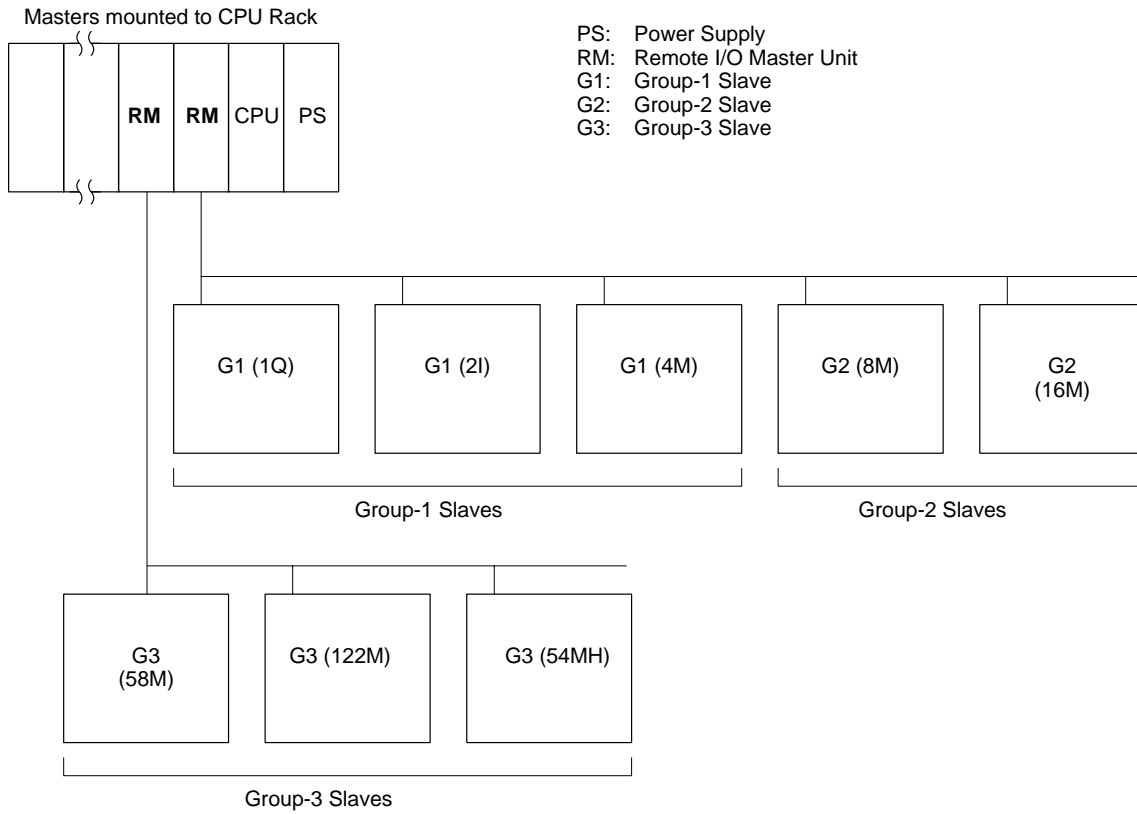

2-4-2 Expansion Racks

| | | |
|---------------------------|----------------------------------|--|
| System Limitations | CPU Rack: | CV500, CV1000, CV2000, or CVM1 |
| | Number of Masters: | CV500/CVM1-CPU01-E: 2 max. CV1000/CV2000/CVM1-CPU11-E: 4 max. |
| | Number of I/O Points for Slaves: | CV500/CVM1-CPU01-E: 1,024 max. CV1000/CV2000/CVM1-CPU11-E: 2,048 max. |
| | Number of Slaves: | Refer to page 14. |
| | Expansion CPU Rack: | 1 max. |
| | Expansion I/O Racks: | 7 max. (6 max. if an Expansion CPU Rack is used.) |

Masters cannot be mounted to Expansion I/O Racks.

If an Expansion CPU Rack is connected, a CV500-IC101 I/O Control Unit must be mounted to the CPU Rack and a CV500-II101 I/O Interface Unit must be mounted to the Expansion CPU Rack.

A CV500-II201 I/O Interface Unit must also be mounted to an Expansion I/O Rack.

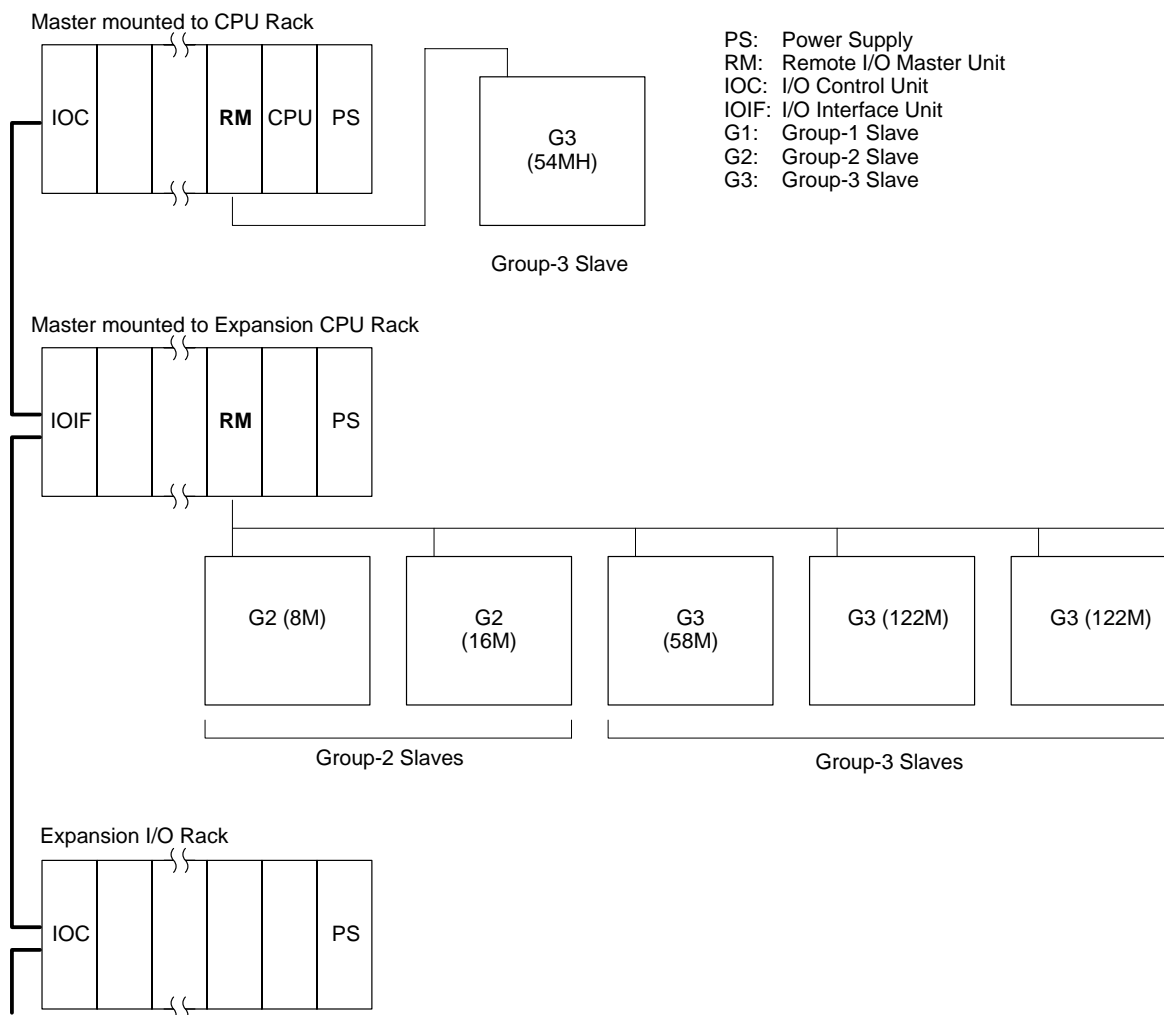

2-4-3 Special I/O Units

System Limitations

| | |
|----------------------------------|--|
| CPU Rack: | CV500, CV1000, CV2000, or CVM1 |
| Number of Masters: | CV500/CVM1-CPU01-E: 2 max. CV1000/CV2000/CVM1-CPU11-E: 4 max. |
| Number of I/O Points for Slaves: | CV500/CVM1-CPU01-E: 1,024 max. CV1000/CV2000/CVM1-CPU11-E: 2,048 max. |
| Number of Slaves: | Refer to page 14. |

The I/O READ/WRITE instructions (READ(190) and WRIT(191)) can be executed for Special I/O Units mounted to Slave Racks only under certain conditions. Refer to *Appendix A Standard Models* for details.

Up to eight Special I/O Units can be mounted to each Slave Rack.

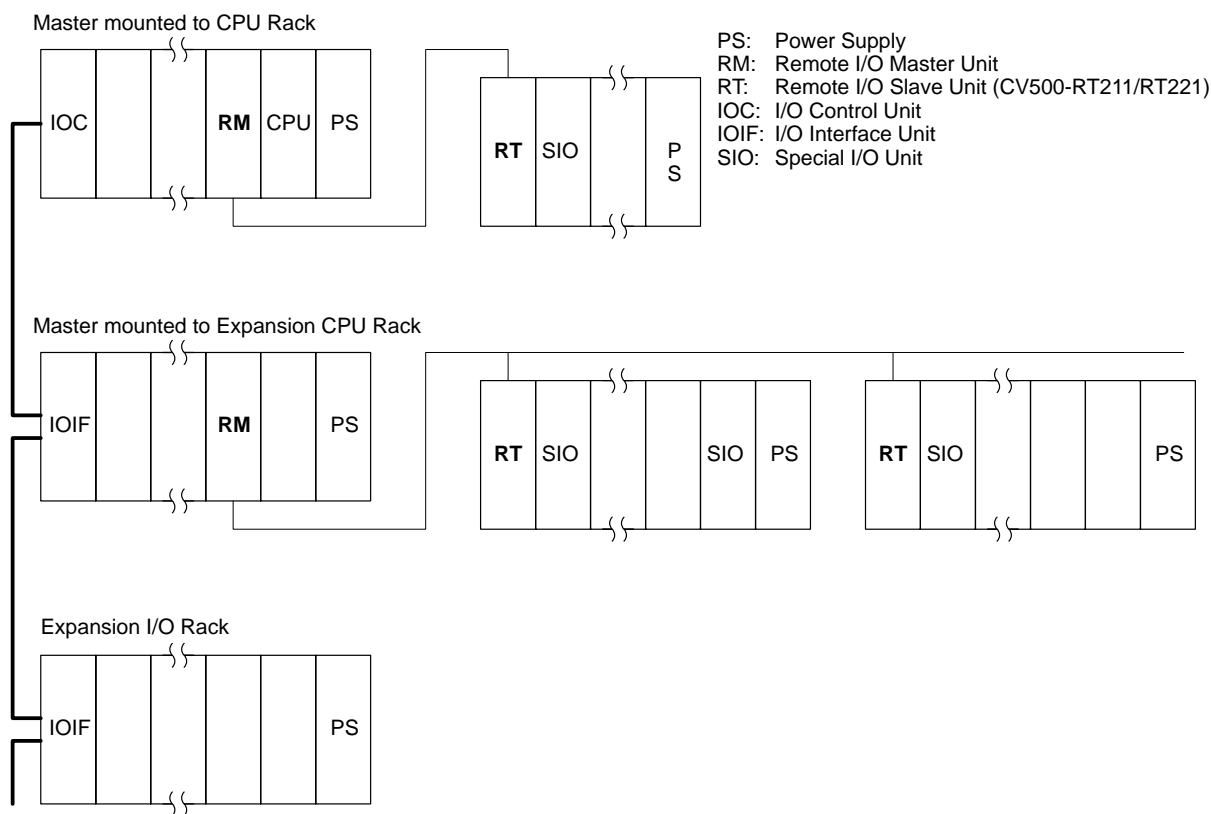

2-4-4 Peripheral Devices

| | | |
|---------------------------|----------------------------------|--|
| System Limitations | CPU Rack: | CV500, CV1000, CV2000, or CVM1 |
| | Number of Masters: | CV500/CVM1-CPU01-E: 2 max. CV1000/CV2000/CVM1-CPU11-E: 4 max. |
| | Number of I/O Points for Slaves: | CV500/CVM1-CPU01-E: 1,024 max. CV1000/CV2000/CVM1-CPU11-E: 2,048 max. |
| | Number of Slaves: | Refer to page 14. |
| | Peripheral Devices: | CVSS, GPC, Programming Console |
| | Number of Peripheral Devices: | 1 per Slave, 2 per Master, 4 per PC |

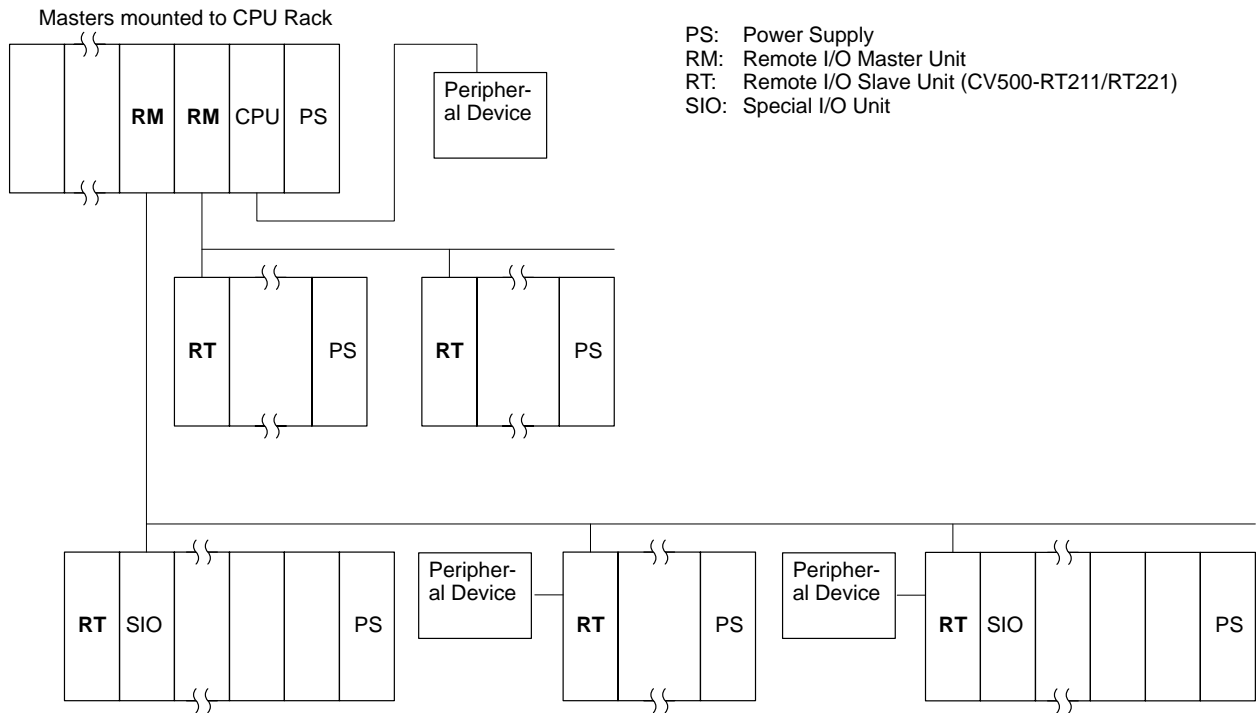

SECTION 3

Installation

This section describes parts of the Remote I/O Master Units and Remote I/O Slaves Units, explains the operation of their indicators and displays, and provide connection methods for installing them. Switch settings necessary for operation are provided in *Section 4 Switch Settings and Word Allocation*.

| | | |
|-------|---|----|
| 3-1 | Remote I/O Master Units | 26 |
| 3-2 | Remote I/O Slave Units | 28 |
| 3-3 | Wiring | 30 |
| 3-3-1 | Optical Systems (CV500-RM211 and CV500-RT211) | 30 |
| 3-3-2 | Wired Systems (CV500-RM221 and CV500-RT221) | 33 |

3-1 Remote I/O Master Units

The following illustrations show the parts of CV500-RM211 and CV500-RM221 Masters.

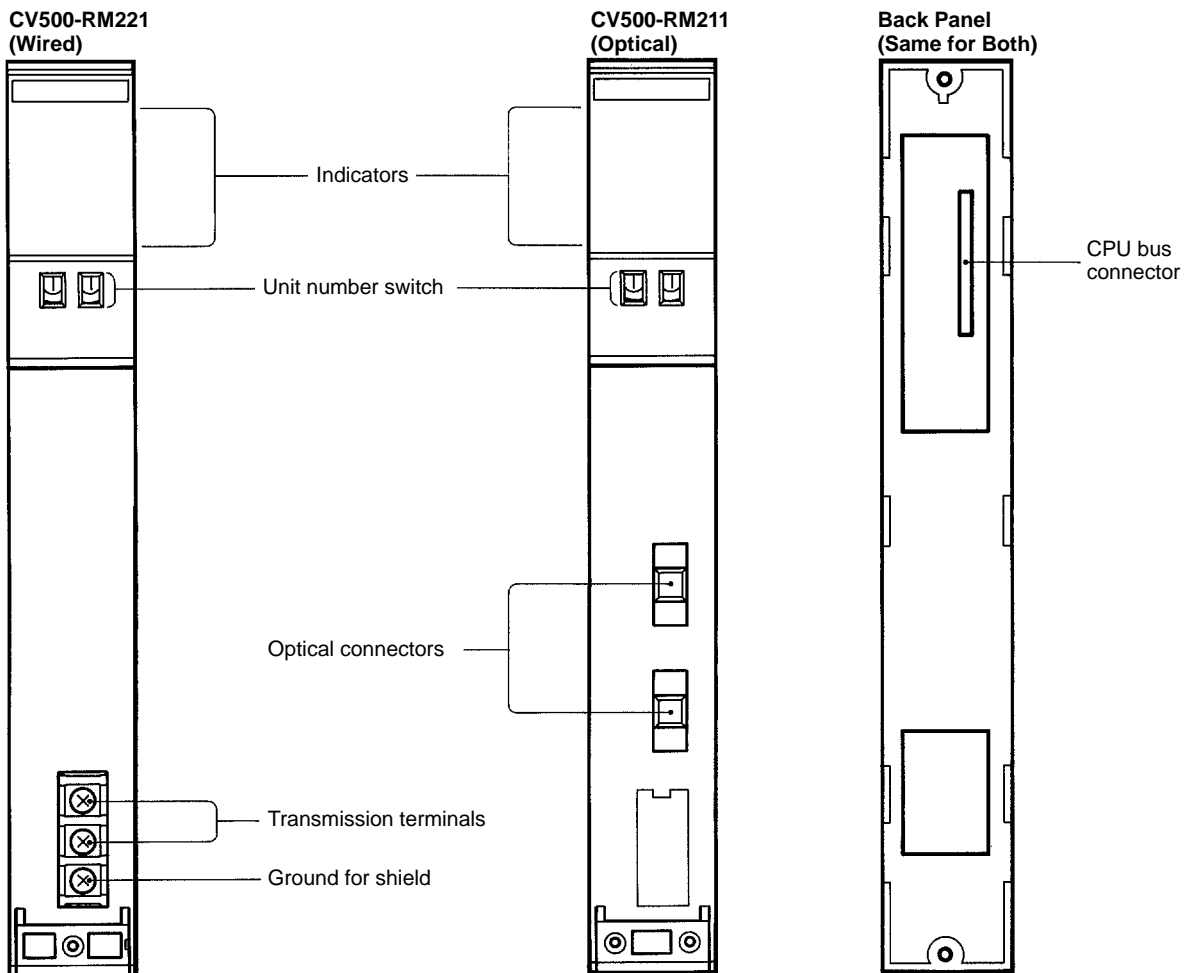

Indicators

The indicators are LEDs that show operating conditions.

Unit Number Switch

These rotary switches are used to set the unit number of the Master as a CPU Bus Unit. The CPU Bus Unit unit number must be within a range of 0 to 15. Use a standard screwdriver to change the number. The unit number setting will determine which words are allocated to the Master in the CPU Bus Unit Area. For details, refer to *Section 4 Switch Settings and Word Allocations*.

Transmission Terminals

These terminals are connected to the Slaves to enable communications in Wired Systems. When connecting Slaves, positive must be connected to positive and negative to negative.

Ground for Shield

This ground must be wired to prevent electrical noise from causing transfer errors in Wired Systems

Optical Connectors

These connectors are connected to the Slaves to enable communications in Optical Systems. For loop connections, both connectors are used. When not making a loop connection, cover the unused connector.

CPU Bus Connector

This connector connects the Master to the CPU bus on the Backplane.

Indicators

CV500-RM211 (Optical)

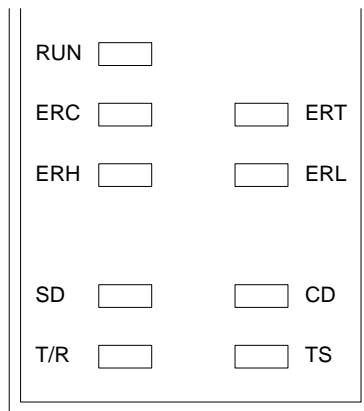

CV500-RM221 (Wired)

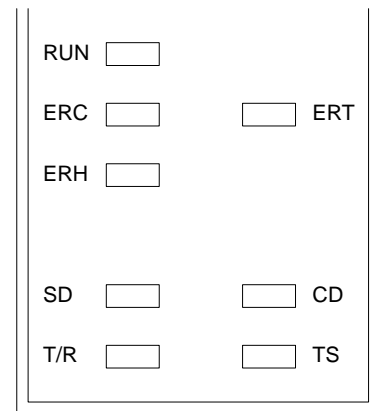

| Indicator | Color | Indication | Status | Meaning |
|-----------|--------|-------------------------|----------|--|
| RUN | Green | Operating status | Lit | Unit operating properly. |
| | | | Not lit | Unit stopped. |
| T/R | Orange | Data transfer status | Lit | Data being transferred. |
| | | | Not lit | Data transfer stopped or completed. |
| TS | Orange | Test status | Lit | Communications test being conducted. |
| | | | Flashing | Communications test completed and error occurred. |
| | | | Not lit | Communications test completed with no error. |
| SD | Orange | Data transmission | Lit | Data being transmitted. |
| | | | Not lit | Data transmission stopped. |
| CD | Orange | Data reception | Lit | Data being received. |
| | | | Not lit | Data reception stopped. |
| ERC | Red | Communications error | Lit | Communications controller error occurred. The Master will not operate while this indicator is lit. |
| | | | Not lit | Communications controller normal. |
| ERH | Red | CPU bus error | Lit | Error in transmission of data between Master and CPU. Data is not refreshed between the Master and CPU while this indicator is lit. |
| | | | Not lit | Normal |
| ERT | Red | Transmission error | Lit | Transmission error occurred. Turns OFF upon recovery. |
| | | | Not lit | Normal |
| ERL | Red | Transmission path error | Lit | Loop error occurring. This indicator will not light unless the Slaves have been connected in a loop. |
| | | | Not lit | Loop normal or Slaves not connected in a loop. |

3-2 Remote I/O Slave Units

The following illustrations show the parts of the CV500-RT211 and RT211 Remote I/O Slave Units.

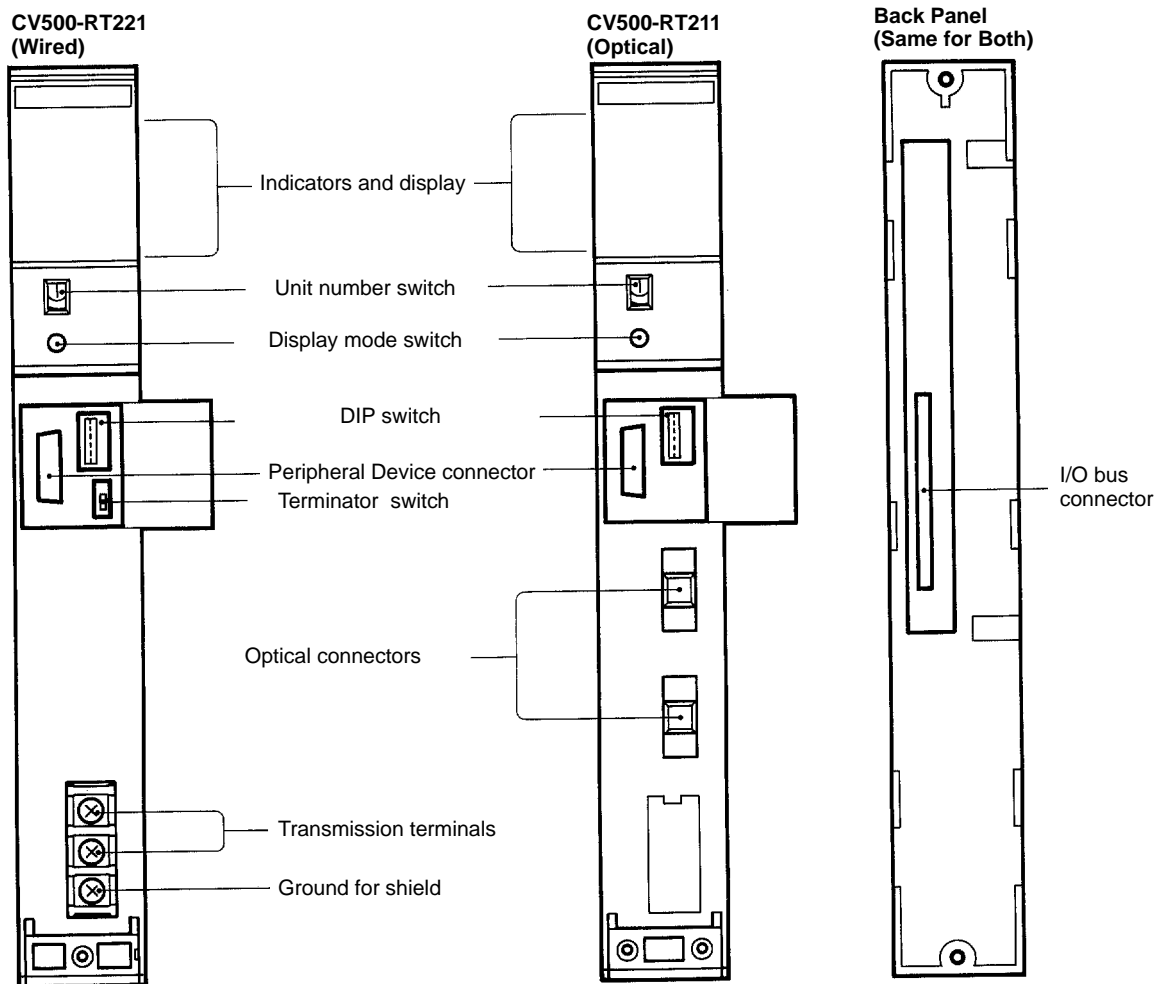

Indicators and Display

The indicators are LEDs that show operating conditions. The display is a 7-segment display that can be set to show desired status or settings.

Unit Number Switch

This rotary switch is used to set the unit number of the Slave within a range of 0 to 15. Use a standard screwdriver to change the number of a Unit. For details, refer to *Section 4 Switch Settings and Word Allocations*.

DIP Switch

This switch is used to set the terminator and the operating parameters for the Slave. For details, refer to *4-3 Other Switch Settings*.

Display Mode Switch

This switch is used for changing the display mode for the 7-segment display.

Peripheral Device Connector

This connector is used to connect a Programming Device to the Slave.

Transmission Terminals

These terminals connect the Slave to the Remote I/O System to enable communications in Wired Systems. When connecting Slaves, positive must be connected to positive and negative to negative.

Ground for Shield

This ground must be wired to prevent electrical noise from causing transfer errors in Wired Systems

Optical Connectors

These connectors connect the Slave to the Remote I/O System to enable communications in Optical Systems. For loop connections, both connectors are used. When not making a loop connection, cover the unused connector.

I/O Bus Connector

This connector connects the Slave to the Backplane.

Indicators

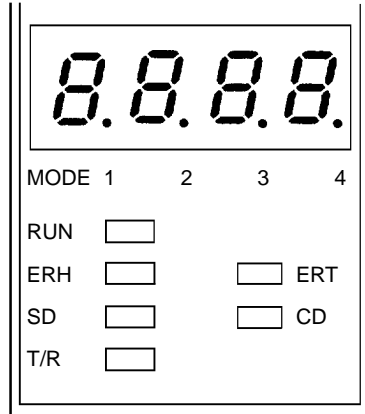

| Indicator | Color | Indication | Status | Meaning |
|--------------------------|--------|----------------------|--|--|
| RUN | Green | Slave status | Lit | Unit operating properly. |
| | | | Not lit | Unit stopped. |
| T/R | Orange | Data transfer status | Lit | Data being transferred. |
| | | | Not lit | Data transfer stopped or completed. |
| SD | Orange | Data transmission | Lit | Data being transmitted from the Unit. |
| | | | Not lit | Data transmission stopped from the Unit. |
| CD | Orange | Data reception | Lit | Data being received. |
| | | | Not lit | Data reception stopped. |
| ERH | Red | I/O bus error | Lit | I/O bus error occurred. |
| | | | Not lit | Normal |
| ERT | Red | Transmission error | Lit | Transmission error occurred. |
| | | | Not lit | Normal |
| 7-segment display | | | When the display mode switch is pressed, the display mode will change sequentially from mode 1 through to mode 4 and then back to mode 1. The mode that is selected will determine the data that is displayed. | |

3-3 Wiring

This section provides the connection methods for Remote I/O Master and Remote I/O Slave Units. Refer to the individual operation manuals for other Slaves and Special I/O Units for details on wiring these Units and to the *CV-series PC Installation Guide* for details on wiring I/O Units.

3-3-1 Optical Systems (CV500-RM211 and CV500-RT211)

Slaves should be wired in order beginning at the Master and ending with the farthest Slave. Use the following procedure.

- 1, 2, 3...
 1. Insert the bushings into the mounting bracket and then insert and fasten the screws.
 2. Pass the tension members through the holes in the terminals and fasten them by tightening the terminal screws. Skip this step if the cables do not have tension members.
 3. Hold the cable and fasten it to the mounting bracket. If the Unit is being connected to two other Units, fasten both cables at the same time.

4. Hold the cable connectors with the latches on the left and push them all the way in.

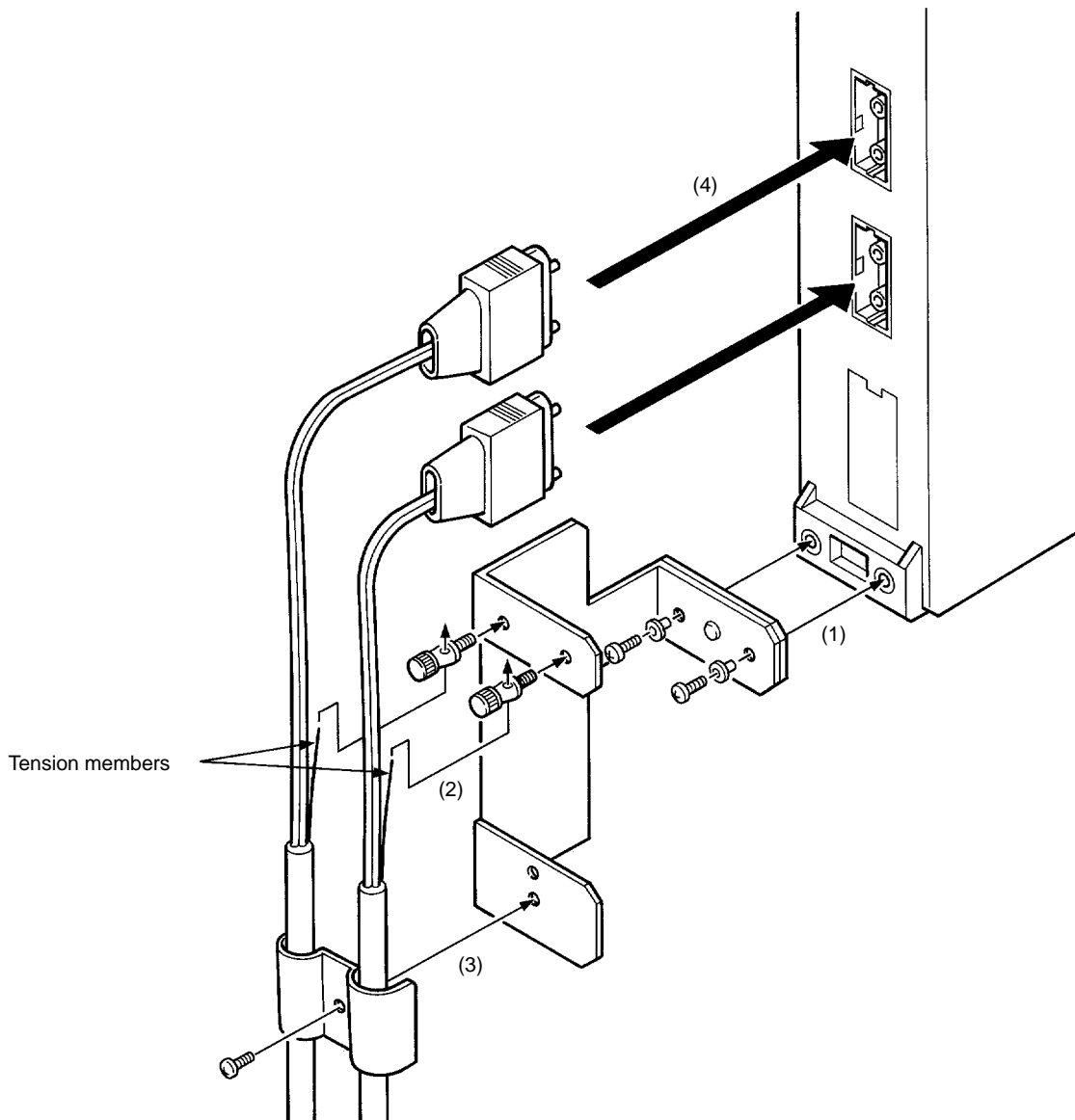

Wiring Precautions

Be sure to use the proper cables, as shown in *Appendix A Standard Models*. When attaching or removing cables, be sure to hold the connectors firmly. There are different connection methods, as shown in the following illustrations. Be careful to use the appropriate method for your System.

Daisy Chaining

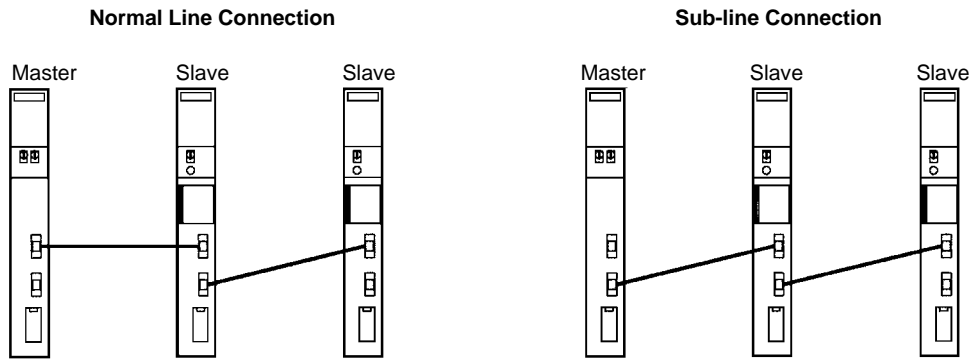

Loop Connections

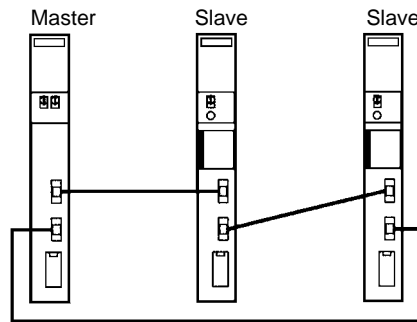

The bending radius must be 100 mm or greater. To ensure this, leave a space of 200 mm below the Unit as shown in the following illustration.

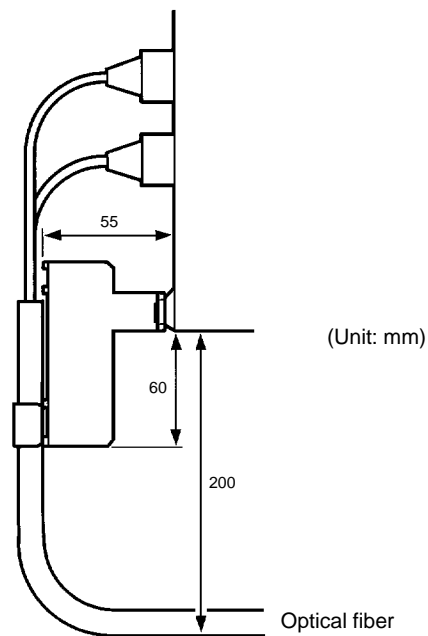

3-3-2 Wired Systems (CV500-RM221 and CV500-RT221)

Slaves should be wired in order beginning at the Master and ending with the farthest Slave. Connect positive to positive and negative to negative, and also connect the shield wire. Use one of the following procedures.

Using Mounting Brackets

- 1, 2, 3...** 1. Pull the shield wire back over the cladding. Attach fork terminals (M3.5) to both the positive and negative wires.

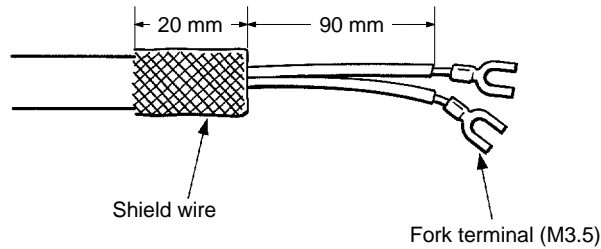

2. Attach the mounting bracket to the shield ground and fasten it with the screws.
3. Fasten the mounting bracket to the Unit.
4. Hold the shield wire that was pulled over the cladding and fasten the cable to the mounting bracket. If the Unit is being connected to two other Units, fasten both cables at the same time.
5. In order not to mix up the positive and negative lines, fasten the fork terminals to the transmission terminals with screws. If the Unit is being connected to two other Units, fasten the line from the preceding terminal and the line to the next terminal at the same time.

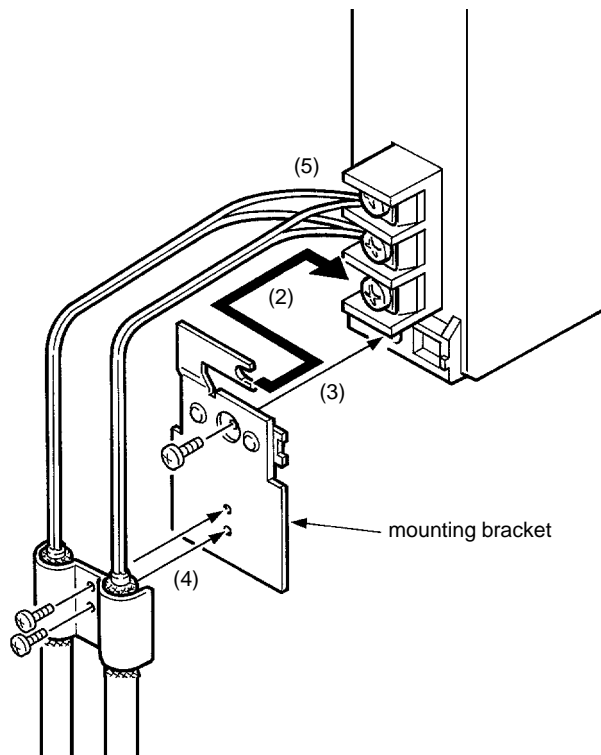

Not Using Mounting Brackets

- 1, 2, 3...** 1. Twist the shield wire and attach a fork terminal to the tip. Cover the bare wire with a heat-contracting tube or wrap it with vinyl tape. Also attach fork terminals to the positive and negative lines.

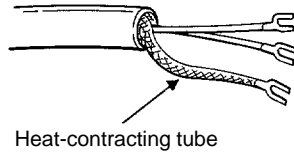

2. In order not to mix up the positive and negative lines, fasten the fork terminals to the transmission terminals with screws. If the Unit is being connected to two other Units, fasten the line from the preceding terminal and the line to the next terminal at the same time.

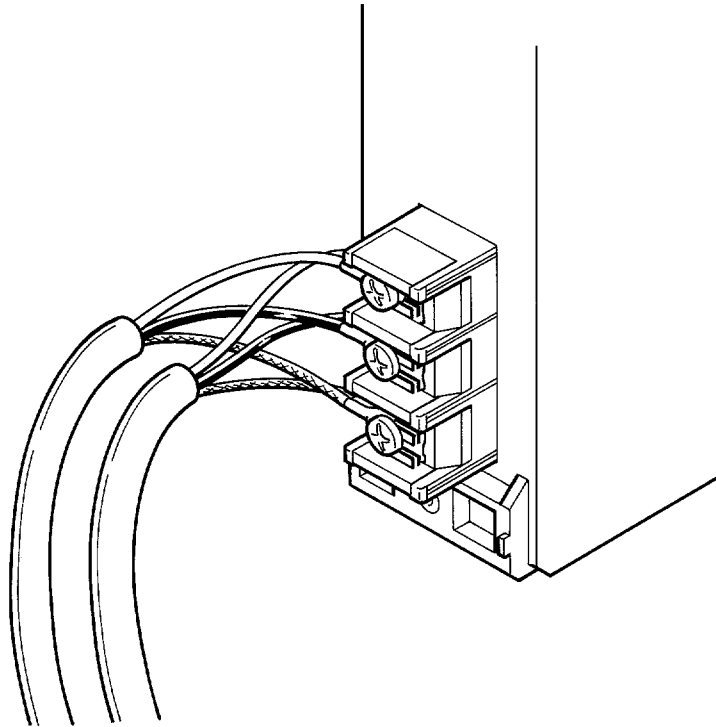

Wiring Precautions

Do not wire the cables in parallel with or in the vicinity of high-voltage lines.
Be sure to connect the shield wires.
Use the following products for wiring:

| Cables connectors | Shielded twisted-pair cable |
|-------------------|-----------------------------|
| Fork terminals | M3.5 |

Keep the total length of wire connected to each Master to within 500 m.

The bending radius must be 100 mm or greater. To ensure this, leave a space of 140 mm below the Unit as shown in the following illustration.

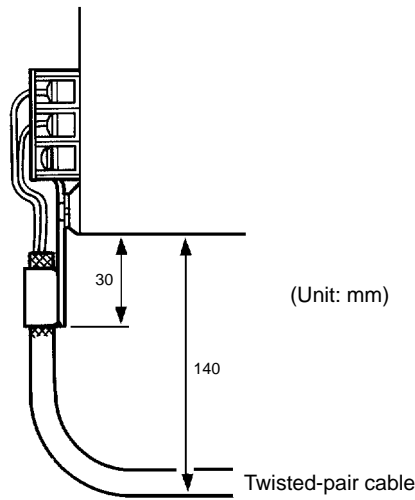

Do not connect Masters and Slaves in the following ways:

Examples: Incorrect Connections

| | | |
|--|--|---|
| <p>Do not connect positive to negative.</p> | | <p>The Unit in the middle will not be able to communicate.</p> |
| <p>The Master must be on one end and connected to only one Slave.</p> | | <p>The termination resistance will not be properly set and the System will be unstable.</p> |
| <p>Always connect the shield ground.</p> | | <p>The System will be susceptible to noise.</p> |
| <p>Connect all Slaves in one series; do not branch.</p> | | <p>The termination resistance will not be properly set and the System will be unstable.</p> |

SECTION 4

Switch Settings and Word Allocation

This section describes the switch settings for Master and Slave unit numbers and how these settings affect the words allocated in Remote I/O Systems. Other aspects of word allocation are also described. The other switch settings on the Remote I/O Slave Units are also described along with settings made in the PC's CPU from a Peripheral Device.

| | | |
|-------|--|----|
| 4-1 | Overview | 38 |
| 4-2 | Word Allocation | 38 |
| 4-2-1 | Mounting Locations and Basic Word Allocation | 38 |
| 4-2-2 | Remote I/O Master Units | 39 |
| 4-2-3 | Slaves | 40 |
| 4-2-4 | Precautions | 43 |
| 4-2-5 | Allocation Examples | 43 |
| 4-3 | Other Switch Settings | 48 |
| 4-4 | Unit Settings | 49 |

4-1 Overview

Before a Remote I/O System can be operated, various parameters must be set and I/O words must be allocated. Some parameters are set on switches on the Masters and Slaves, other are set in the PC's CPU via a Peripheral Device (e.g., the CVSS).

| Item | Summary | Setting | Section |
|--|---|------------------------------------|---------|
| Unit number settings and word allocation | Allocation of words for Master via CPU Bus Unit number | Rotary switch on Master | 4-2 |
| | Allocation of words for Slaves via Slave unit numbers or the PC Setup | Rotary switch on Slave or via CVSS | |
| Other switch settings | Setting of terminator for Wired Systems | Terminator switch on Wired Slaves | 4-3 |
| | Setting of data status for communications errors | DIP switch pin 4 on Slaves | |
| | Setting of Slave type | DIP switch pins 5 and 6 on Slaves | |
| | Setting of speed of communications with Peripheral Device | DIP switch pins 1 and 2 on Slaves | |
| Unit settings | Hardware check Communications error processing Error check | Set in PC's CPU via CVSS. | 4-4 |
| | Communications cycle time | | |
| | Transmission error count | | |
| | Response monitoring time | | |

4-2 Word Allocation

The words allocated to Units in a Remote I/O Systems are determined by the following factors.

- The unit numbers set for the Masters, which indirectly determine the master numbers.
- The unit numbers set for the Slaves.
- The order in which Units are mounted on Racks, including Slave Racks.
- The setting in the PC Setup, which can be used to changed the default allocators for Slave groups and individual Racks.

4-2-1 Mounting Locations and Basic Word Allocation

I/O Units and Special I/O Units can be mounted to any non-dedicated slot on the CPU Rack, the Expansion CPU Rack, Expansion I/O Racks, or Slave Racks. Word numbers are allocated in order, to the Units from left to right beginning on the CPU Rack and then left to right on the Expansion CPU Rack and Expansion I/O Racks. Each word is allocated the number of bits it requires. No words are allocated to empty slots.

As words are allocated, words for Slaves also allocated from left to right on the Rack, but are allocated starting from a different point in memory, as described later.

Each word consists of 16 bits, and each word has a 4-digit word address. A bit address includes the bit number (00 to 15) added to the word address. For example, the bit address 001508 indicates bit 08 of word 0015. For details on addressing conventions and basic word allocation, refer to the *CV-series PC Operation Manual: Ladder Diagrams*.

The following example shows two Masters on a CPU Rack and the allocations to the CPU Rack one of the Slave Racks.

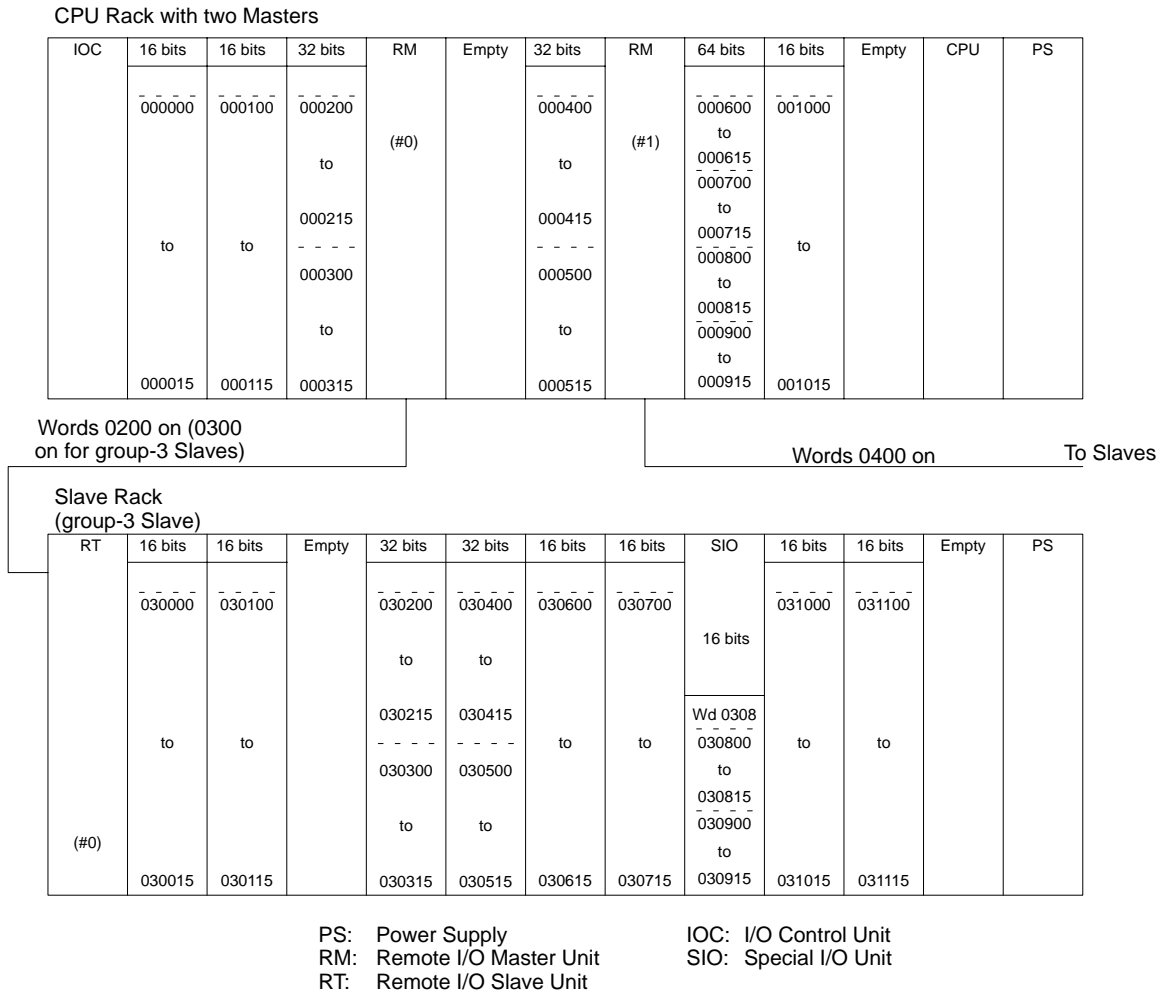

Note The above example assumes that the first word for each Rack has not been changed in the PC Setup in the CPU.

4-2-2 Remote I/O Master Units

Unit numbers are set and words are allocated to Masters as follows:

CPU Bus Unit Number (#) Each Master has a unit number as a CPU Bus Unit. You can set any number within a range of #0 to #15 as long as the same number is not set for another CPU Bus Unit. The symbol “#” indicates a CPU Bus Unit number.

The switches for setting the unit number are rotary switches. The switch on the left sets the 10’s digit, and the switch on the right sets the 1’s digit. Use a standard screwdriver for making the settings.

Note Unit numbers can be set within the allowable range without regard to the mounting positions of CPU Bus Units. They do not have to begin with #0, and they do not have to be in order. The same number cannot, however, be set for more than one CPU Bus Unit.

The following illustration shows how to make the settings.

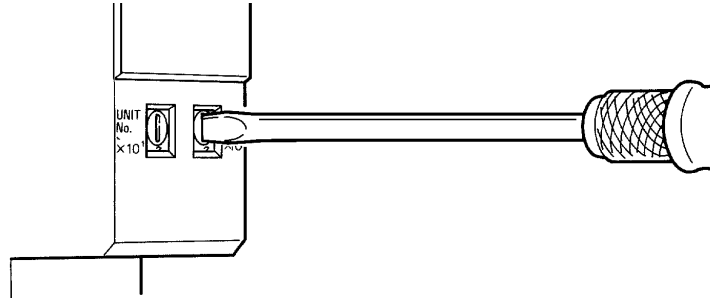

Master Numbers (&)

Each Master also has a number called a master number. Master numbers are automatically assigned in the same order (&0, &1, &2, etc.) as the unit numbers that have been set as described above, e.g., if the lowest unit number assigned to a Master is #4, that Master will be allocated master number &0. The symbol “&” indicates a master number.

Word Allocations

Each Master is allocated 200 I/O words from the SYSMAC BUS/2 Area for allocation to the Slaves connected to it. The Master with the smallest master number is allocated words CIO 0200 to CIO 0399, and each subsequent Master is allocated the next 200 words. If you wish, you can use a Peripheral Device to change the first word for each Slave group in the PC Setup

For example, if there are 15 CPU Bus Units mounted and Units #0, #3, #4, and #8 are Masters, the default allocation of words will be as follows:

| Unit number | Master number | Word allocations | |
|-------------|---------------|----------------------|----------------------------|
| | | CV500/CVM1-CPU01-E | CV1000/CV2000/CVM1-CPU11-E |
| #0 | &0 | CIO 0200 to CIO 0399 | CIO 0200 to CIO 0399 |
| #3 | &1 | CIO 0400 to CIO 0599 | CIO 0400 to CIO 0599 |
| #4 | &2 | NA | CIO 0600 to CIO 0799 |
| #8 | &3 | NA | CIO 0800 to CIO 0999 |

The above words are further broken down for allocation to the various groups of Slaves connected to the Masters (see next section).

Master are also allocated words as CPU Bus Units from the CPU Bus Unit Area (CIO 1500 through CIO 1899). Words are allocated to CPU Bus Units according their unit number settings as shown in the following tables.

| Unit # | 0 | 1 | 2 | 3 | 4 | 5 | 6 | 7 |
|------------------|--------------|--------------|--------------|--------------|--------------|--------------|--------------|--------------|
| CIO words | 1500 to 1524 | 1525 to 1549 | 1550 to 1574 | 1575 to 1599 | 1600 to 1624 | 1625 to 1649 | 1650 to 1674 | 1675 to 1699 |

| Unit # | 8 | 9 | 10 | 11 | 12 | 13 | 14 | 15 |
|------------------|--------------|--------------|--------------|--------------|--------------|--------------|--------------|--------------|
| CIO words | 1700 to 1724 | 1725 to 1749 | 1750 to 1774 | 1775 to 1799 | 1800 to 1824 | 1825 to 1849 | 1850 to 1874 | 1875 to 1899 |

An additional 1600 words in the DM Area (D02000 to D03599) are provided for CPU Bus Units, but these words are not used in Remote I/O Systems

4-2-3 Slaves

Unit Numbers

A unit number must also be set for each Slave. These unit number are used in determining the words allocated to each Slave, as described later. The setting ranges for Slave unit numbers vary from group to group, as shown in the follow-

ing table. The same number cannot be set for two Slaves in the same group connected to the same Master. The same number can be set, however, for Slaves in different groups or for Slaves connected to different Masters.

| Slave group | Slave unit numbers |
|-------------|--------------------|
| Group 1 | #0 to #31 |
| Group 2 | #0 to #15 |
| Group 3 | #0 to #7 |

Set the Slave unit numbers for the CV500-RT211 and CV500-RT221 Slaves within a range of #0 to #7. The switch for setting the Slave unit number is a rotary switch. Use a standard screwdriver to make the setting. After setting the rotary switch, the power can be turned on with the communications cables disconnected and then the display mode switch can be pressed to display switch settings. For details, refer to page 48.

The following illustration shows how to set the Slave unit number.

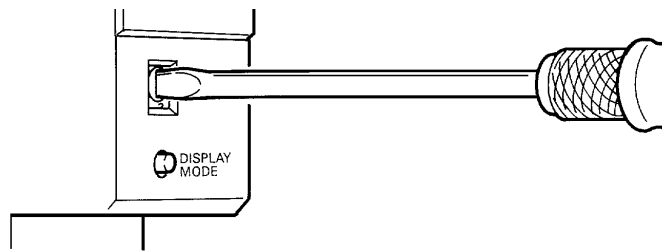

- Note**
1. Slave unit numbers are not related to the order in which the Slaves are physically connected to the Master, so you can set them freely within the allowable range. It is not necessary to begin with #0 or to set numbers consecutively.
 2. If Slave unit numbers are set to #8 or #9 for group-3 Slaves, the System will not operate. If this occurs, turn off the power, reset the numbers within a range of #0 to #7, and recreate the I/O table.
 3. If the same unit number is set to more than one Slave, the PC may ignore the existence of those Slaves when it starts up.

Word Allocations

The first word allocated to each Slave group is automatically determined according to the master number. You can set the first words for each group by means of the PC Setup. The default settings are as follows:

| Master number | Group 1 | Group 2 | Group 3 |
|---------------|---------|---------|---------|
| &0 | CIO 200 | CIO 250 | CIO 300 |
| &1 | CIO 400 | CIO 450 | CIO 500 |
| &2 | CIO 600 | CIO 650 | CIO 700 |
| &3 | CIO 800 | CIO 850 | CIO 900 |

- Note** If you need more than 50 words for group-1 or group-2 Slaves, you must set the first words in the PC Setup. Be sure that the words do not overlap those of Slaves in other groups. If there are overlapping words, an address duplication error will be generated and you will not be able to create an I/O table. For details on the PC Setup, refer to the *CVSS Operation Manual: Offline*.

Words are automatically allocated to Slaves in order, within the ranges shown above, beginning with the Slave with the lowest Slave unit number. For Slave Racks created with the CV500-RT211/RT221, the words for the Slave are automatically allocated to Units on the Rack from left to right.

Example

The following examples shows the words allocated to the Slaves for Master #0. Words would also be allocated to the Slaves for the other Master in a similar

fashion from the regions allocated for them. For the group-3 Slaves, the words allocated to them would be allocated to the Units on the Slave Rack from left to right in the same fashion that words are allocated to Units on other Racks.

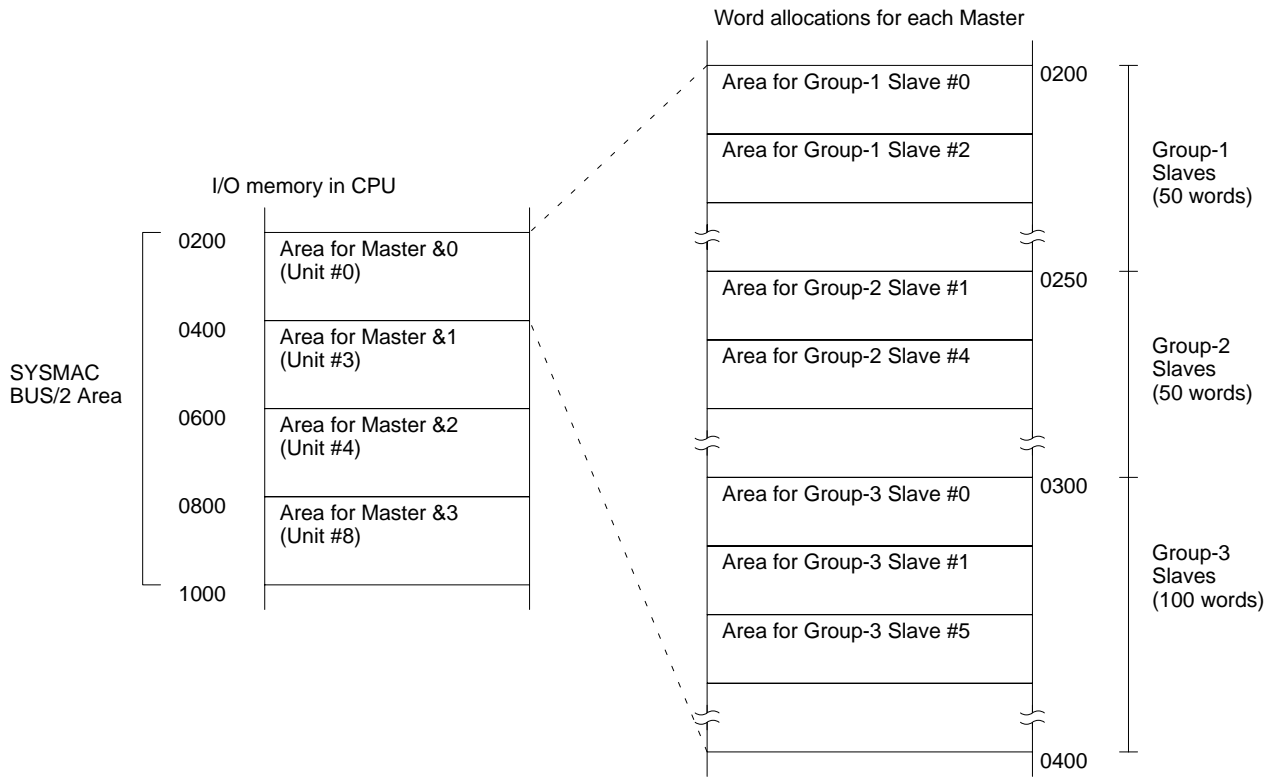
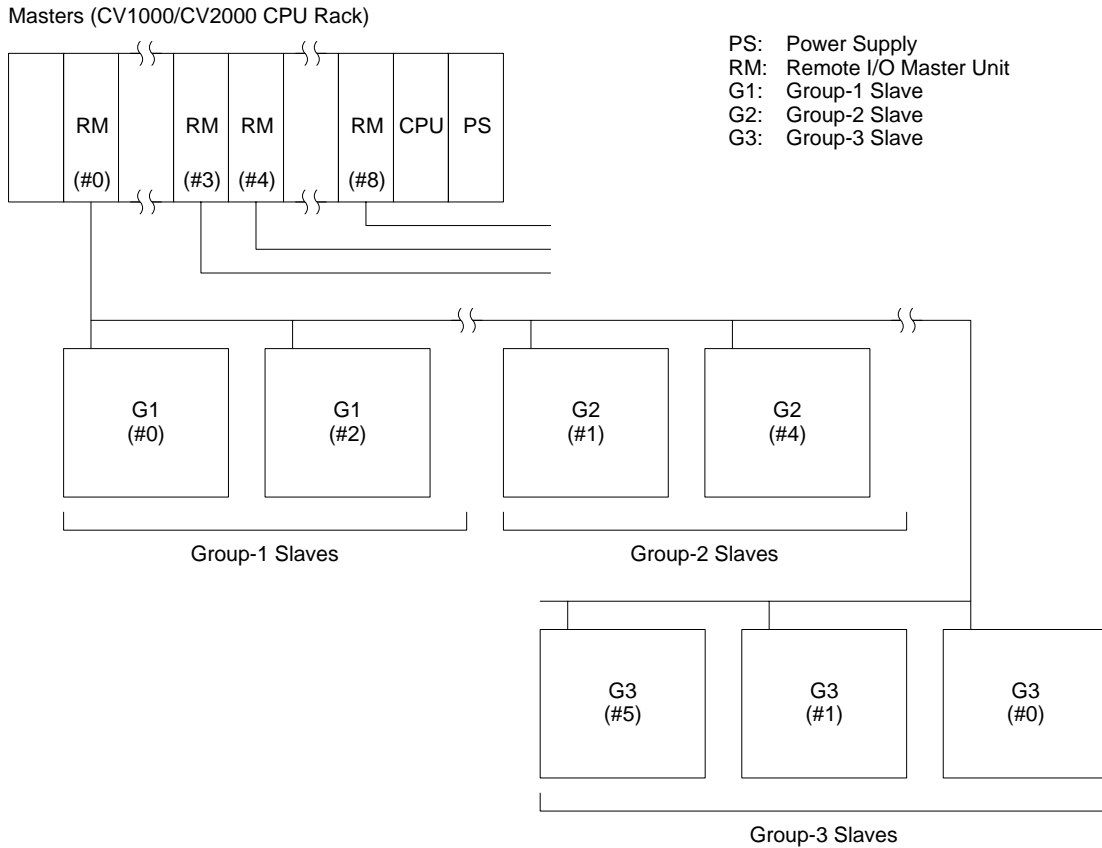

4-2-4 Precautions

After mounting Units, you must generate the I/O table. This operation allocates words for the Units that were mounted and registers the I/O table.

Empty slots without Units mounted are not allocated words. If you plan to mount more Units later, you can add dummy I/O words by using a Dummy I/O Units or by changing the I/O table after generation.

If Units are added, changed, or removed after I/O table generation, word allocations will not agree with the Units actually mounted and an I/O verification error and an I/O setting error will be generated. When removing a Unit, the I/O table can be changed or a Dummy I/O Unit added to prevent changing word allocations. If word allocations are changed, all addresses in the program from the point at which the Unit was added or changed will have to be changed.

For details concerning generating and changing the I/O table, refer to the *CVSS Operation Manual: Online*.

4-2-5 Allocation Examples

The following examples show specific allocations for various types of system configuration. All of these examples assume that the default PC Setup is being used.

Slaves Only

The following System includes a CPU Rack with two Masters, three group-3 Slaves, three group-1 Slaves, and two group-2 Slaves.

CPU Rack

| | | | | | | | | | | | | |
|--|---------------------------------------|---------------------------------------|-------|-----------------------|----------------------|----------------------|-----------------------|----------------------|---------------------------------------|-------|-----|----|
| | 32 points Wd 0000 to Wd 0001 | 32 points Wd 0002 to Wd 0003 | Empty | RM (#0) | 16 points Wd 0004 | 16 points Wd 0005 | RM (#1) | 16 points Wd 0006 | 32 points Wd 0007 to Wd 0008 | Empty | CPU | PS |
|--|---------------------------------------|---------------------------------------|-------|-----------------------|----------------------|----------------------|-----------------------|----------------------|---------------------------------------|-------|-----|----|

Terminator

| | | | | | | | | | | | | |
|-----------------------|-------|-------|----------------------|---------------------------------------|---------------------------------------|----------------------|----------------------|----------------------|-------|-------|-------|----|
| RT (#0) | Empty | Empty | 16 points Wd 0500 | 64 points Wd 0501 to Wd 0504 | 32 points Wd 0505 to Wd 0506 | 16 points Wd 0507 | 16 points Wd 0508 | 16 points Wd 0509 | Empty | Empty | Empty | PS |
|-----------------------|-------|-------|----------------------|---------------------------------------|---------------------------------------|----------------------|----------------------|----------------------|-------|-------|-------|----|

| | | | | | | | | | | | | |
|-----------------------|---------------------------------------|---------------------------------------|----------------------|----------------------|----------------------|----------------------|----------------------|----------------------|----------------------|-------|-------|----|
| RT (#0) | 32 points Wd 0300 to Wd 0301 | 32 points Wd 0302 to Wd 0303 | 16 points Wd 0304 | 16 points Wd 0305 | 16 points Wd 0306 | 16 points Wd 0307 | 16 points Wd 0308 | 16 points Wd 0309 | 16 points Wd 0310 | Empty | Empty | PS |
|-----------------------|---------------------------------------|---------------------------------------|----------------------|----------------------|----------------------|----------------------|----------------------|----------------------|----------------------|-------|-------|----|

| | |
|-----------------------|----------------------|
| G1 (#0) | 16 points Wd 0200 |
|-----------------------|----------------------|

| | |
|-----------------------|---------------------------------------|
| G1 (#1) | 32 points Wd 0201 to Wd 0202 |
|-----------------------|---------------------------------------|

| | | |
|-----------------------|------------------------------------|------------------------------------|
| G1 (#2) | 32 points Wd 0203 to Wd 0204 | 32 points Wd 0205 to Wd 0206 |
|-----------------------|------------------------------------|------------------------------------|

| | | |
|-----------------------|--|--|
| G2 (#1) | 128 points Wd 0258 to Wd 0265 | 128 points Wd 0266 to Wd 0273 |
|-----------------------|--|--|

| | | |
|-----------------------|---------------------------------------|---------------------------------------|
| G2 (#0) | 64 points Wd 0250 to Wd 0253 | 64 points Wd 0254 to Wd 0257 |
|-----------------------|---------------------------------------|---------------------------------------|

Terminator

| | | | | | |
|-----------------------|---------------------------------------|---------------------------------------|---------------------------------------|---------------------------------------|----------------------|
| G3 (#1) | 32 points Wd 0311 to Wd 0312 | 32 points Wd 0313 to Wd 0314 | 32 points Wd 0315 to Wd 0316 | 32 points Wd 0317 to Wd 0318 | 16 points Wd 0319 |
|-----------------------|---------------------------------------|---------------------------------------|---------------------------------------|---------------------------------------|----------------------|

PS: Power Supply
RM: Remote I/O Master Unit

G1: Group-1 Slave
G2: Group-2 Slave
G3: Group-3 Slave
RT: CV500-RT211/RT221 (Slave Rack)

Expansion CPU Rack and Slaves

The following System includes a CPU Rack with two Masters, an Expansion CPU Rack with one Master, three group-3 Slaves, three group-1 Slaves, and two group-2 Slaves.

When connecting an Expansion CPU Rack, a CV500-IC101 I/O Control Unit is required on the CPU Rack and a CV500-II101 I/O Interface Unit is required on the Expansion CPU Rack. The I/O Control Unit and I/O Interface Unit must be mounted in the leftmost slots on their Racks. Connect Termination Resistance Units (CV500-TER01) to the connectors not used on the I/O Control Unit and I/O Interface Unit.

CPU Rack

| | | | | | | | | | | | | |
|-----|-----------|-----------|-----------|-----------|-----------|-----------|-----------|-----------|-----------|-------|-----|----|
| IOC | 32 points | 32 points | 32 points | RM | 32 points | 32 points | RM | 16 points | 16 points | Empty | CPU | PS |
| | Wd 0000 | Wd 0002 | Wd 0004 | | Wd 0006 | Wd 0008 | | Wd 0010 | Wd 0011 | | | |
| | to | to | to | | to | to | | | | | | |
| | Wd 0001 | Wd 0003 | Wd 0005 | (#0) | Wd 0007 | Wd 0009 | (#1) | | | | | |

| | | | | | | | | | | | | | |
|-----------|-----------|-----------|-------|-----------|-----------|-----------|-----------|-----------|-----------|-----------|-------|-----------|----|
| RT | 32 points | 32 points | Empty | 32 points | 32 points | 16 points | 32 points | 32 points | 32 points | 32 points | Empty | 32 points | PS |
| | Wd 0500 | Wd 0502 | | Wd 0504 | Wd 0506 | Wd 0508 | Wd 0509 | Wd 0511 | Wd 0513 | | | | |
| | to | to | | to | to | to | to | to | | | | | |
| (#0) | Wd 0501 | Wd 0503 | | Wd 0505 | Wd 0507 | | Wd 0510 | Wd 0512 | Wd 0514 | | | Wd 0515 | |
| | | | | | | | | | | | | Wd 0516 | |

| | |
|-----------|-----------|
| G1 | 16 points |
| | Wd 0400 |
| (#0) | |

| | |
|-----------|-----------|
| G1 | 32 points |
| | Wd 0401 |
| (#1) | to |
| | Wd 0402 |

| | | |
|-----------|-----------|-----------|
| G1 | 32 points | 32 points |
| | Wd 0403 | Wd 0405 |
| (#2) | to | to |
| | Wd 0404 | Wd 0406 |

| | | |
|-----------|------------|------------|
| G2 | 128 points | 128 points |
| | Wd 0458 | Wd 0466 |
| | to | to |
| (#1) | Wd 0465 | Wd 0473 |

| | | |
|-----------|-----------|-----------|
| G2 | 64 points | 64 points |
| | Wd 0450 | Wd 0454 |
| | to | to |
| (#0) | Wd 0453 | Wd 0457 |

Terminator

Terminator

| | | | | | | | | | | | | |
|-----------|-----------|-----------|-----------|-----------|-----------|-----------|-----------|-------|-----------|-------|-------|----|
| RT | 32 points | 32 points | 32 points | 32 points | 32 points | 16 points | 32 points | Empty | 16 points | Empty | Empty | PS |
| | Wd 0300 | Wd 0302 | Wd 0304 | Wd 0306 | Wd 0308 | Wd 0310 | Wd 0311 | | Wd 0313 | | | |
| | to | to | to | to | to | to | | | | | | |
| (#0) | Wd 0301 | Wd 0303 | Wd 0305 | Wd 0307 | Wd 0309 | | Wd 0312 | | | | | |

Expansion CPU Rack

| | | | | | | | | | | | | |
|------|-----------|-----------|-----------|-----------|-----------|-----------|-----------|-----------|-----------|-------|-------|----|
| IOIF | 32 points | 32 points | 32 points | 32 points | 32 points | 32 points | RM | 32 points | 16 points | Empty | Empty | PS |
| | Wd 0012 | Wd 0014 | Wd 0016 | Wd 0018 | Wd 0020 | Wd 0022 | | Wd 0024 | Wd 0026 | | | |
| | to | to | to | to | to | to | | to | | | | |
| | Wd 0013 | Wd 0015 | Wd 0017 | Wd 0019 | Wd 0021 | Wd 0023 | (#2) | Wd 0025 | | | | |

Terminator

| | | | | | | | | | |
|-----------|-----------|-----------|-----------|-----------|-----------|-----------|-----------|-----------|-----------|
| G3 | 32 points | 32 points | 32 points | 32 points | 32 points | 16 points | 32 points | 32 points | 32 points |
| | Wd 0700 | Wd 0702 | Wd 0704 | Wd 0706 | Wd 0708 | Wd 0710 | Wd 0711 | Wd 0713 | Wd 0715 |
| | to | to | to | to | to | to | to | to | |
| (#0) | Wd 0701 | Wd 0703 | Wd 0705 | Wd 0707 | Wd 0709 | | Wd 0712 | Wd 0714 | Wd 0716 |

PS: Power Supply
 IOC: I/O Control Unit
 IOIF: I/O Interface Unit

RM: Remote I/O Master Unit
 G1: Group-1 Slave
 G2: Group-2 Slave
 G3: Group-3 Slave
 RT: CV500-RT211/RT221 (Slave Rack)

Expansion I/O Racks and Slaves

The following System includes a CPU Rack with one Master, two group-3 Slaves, three group-1 Slaves, and two group-2 Slaves.

Masters cannot be mounted to Expansion I/O Racks.

When connecting an Expansion I/O Rack, a CV500-IC201 I/O Control Unit is required on the CPU Rack and a CV500-II201 I/O Interface Unit is required on the Expansion I/O Rack. The I/O Control Unit and I/O Interface Unit must be mounted in the leftmost slots on their Racks. Connect Termination Resistance Units (CV500-TER01) to the connectors not used on the I/O Control Unit and I/O Interface Unit.

CPU Rack

| | | | | | | | | | | | | |
|-----|-----------|-----------|-----------|-----------|-----------|-----------|-----------|-----------|-----------|-------|-----|----|
| IOC | 32 points | 32 points | 32 points | 16 points | 32 points | 16 points | RM | 32 points | 32 points | Empty | CPU | PS |
| | Wd 0000 | Wd 0002 | Wd 0004 | Wd 0006 | Wd 0007 | Wd 0009 | | Wd 0010 | Wd 0012 | | | |
| | to | to | to | | to | | | to | to | | | |
| | Wd 0001 | Wd 0003 | Wd 0005 | | Wd 0008 | | (#0) | Wd 0011 | Wd 0013 | | | |

| | | | | | | | | | | | | |
|-----------|-----------|-----------|-----------|-----------|-----------|-----------|-----------|---------|-----------|-------|-------|----|
| RT | 32 points | 32 points | 32 points | 32 points | 32 points | 16 points | 32 points | Empty | 16 points | Empty | Empty | PS |
| | Wd 0300 | Wd 0302 | Wd 0304 | Wd 0306 | Wd 0308 | Wd 0310 | Wd 0311 | | | | | |
| | to | to | to | to | to | to | to | | | | | |
| | (#0) | Wd 0301 | Wd 0303 | Wd 0305 | Wd 0307 | Wd 0309 | | Wd 0312 | | | | |

| | |
|-----------|-----------|
| G1 | 16 points |
| | Wd 0200 |
| (#0) | |

| | |
|-----------|-----------|
| G1 | 32 points |
| | Wd 0201 |
| | to |
| (#1) | Wd 0202 |

| | | |
|-----------|-----------|-----------|
| G1 | 32 points | 32 points |
| | Wd 0203 | Wd 0205 |
| | to | to |
| (#2) | Wd 0204 | Wd 0206 |

| | | |
|-----------|------------|------------|
| G2 | 128 points | 128 points |
| | Wd 0258 | Wd 0266 |
| | to | to |
| (#1) | Wd 0265 | Wd 0273 |

| | | |
|-----------|-----------|-----------|
| G2 | 64 points | 64 points |
| | Wd 0250 | Wd 0254 |
| | to | to |
| (#0) | Wd 0253 | Wd 0257 |

Terminator

| | | | | | | | | |
|-----------|-----------|-----------|-----------|-----------|-----------|-----------|-----------|-----------|
| G3 | 16 points | 32 points | 32 points | 32 points | 32 points | 32 points | 32 points | 16 points |
| | Wd 0314 | Wd 0315 | Wd 0317 | Wd 0319 | Wd 0321 | Wd 0323 | Wd 0325 | Wd 0327 |
| | to | to | to | to | to | to | to | |
| (#1) | | Wd 0316 | Wd 0318 | Wd 0320 | Wd 0322 | Wd 0324 | Wd 0326 | |

Expansion CPU Rack

| | | | | | | | | | | | | |
|------|-----------|-----------|-----------|-----------|-----------|-----------|-------|-----------|-----------|-------|-----------|----|
| IOIF | 32 points | 32 points | 32 points | 32 points | 16 points | 32 points | Empty | 16 points | 16 points | Empty | 16 points | PS |
| | Wd 0014 | Wd 0016 | Wd 0018 | Wd 0020 | Wd 0022 | Wd 0023 | | Wd 0025 | Wd 0026 | | | |
| | to | to | to | to | | to | | | | | | |
| | Wd 0015 | Wd 0017 | Wd 0019 | Wd 0021 | | Wd 0024 | | | | | Wd 0027 | |

PS: Power Supply
 IOC: I/O Control Unit
 IOIF: I/O Interface Unit

RM: Remote I/O Master Unit
 G1: Group-1 Slave
 G2: Group-2 Slave
 G3: Group-3 Slave
 RT: CV500-RT211/RT221 (Slave Rack)

Other CPU Bus Units, Special I/O Units, and Slaves

The following System includes a CPU Rack with two Masters, two group-3 Slaves, three group-1 Slaves, and two group-2 Slaves.

CPU Rack

| | | | | | | | | | | | | |
|--|---------------------------------------|---------------------------------------|--------------|----------------------|---------------------------------------|------------|--------------|---------------------------------------|------------|------|-----|----|
| | 64 points Wd 0000 to Wd 0003 | 32 points Wd 0004 to Wd 0005 | CPUB (#0) | 16 points Wd 0006 | 32 points Wd 0007 to Wd 0008 | RM (#1) | CPUB (#2) | 32 points Wd 0009 to Wd 0010 | RM (#3) | Open | CPU | PS |
|--|---------------------------------------|---------------------------------------|--------------|----------------------|---------------------------------------|------------|--------------|---------------------------------------|------------|------|-----|----|

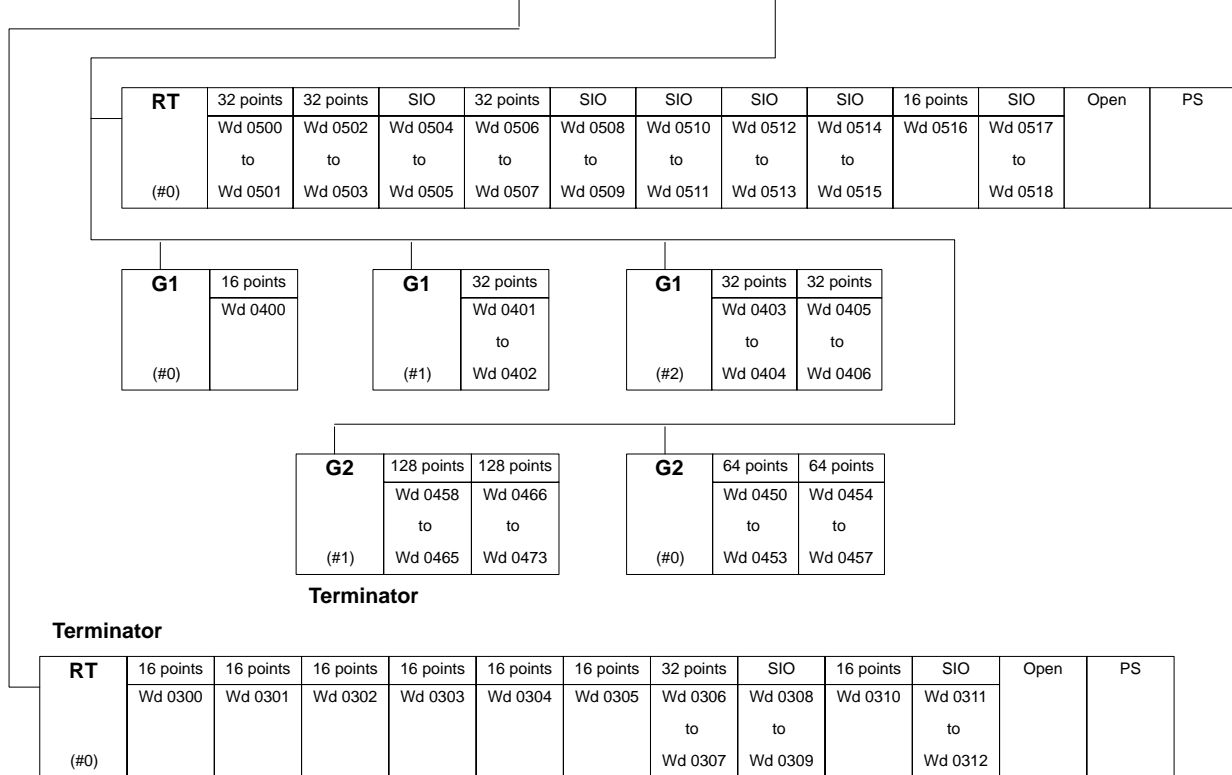

- PS: Power Supply
- IOC: I/O Control Unit
- IOIF: I/O Interface Unit
- CPUB: CPU Bus Unit
- SIO: Special I/O Unit

- RM: Remote I/O Master Unit
- G1: Group-1 Slave
- G2: Group-2 Slave
- RT: CV500-RT211/RT221 (Slave Rack)

4-3 Other Switch Settings

Beneath the cover on the front panel of each Wired CV500 Slave (CV500-RT221), there are both a 6-pin DIP switch and a terminator switch. Optical CV500 Slaves (CV500-RT211) have only the 6-pin DIP switch.

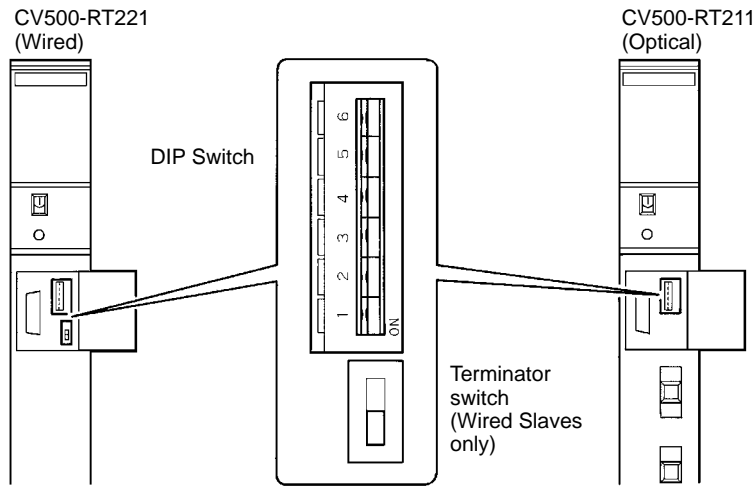

Terminator Switch

The terminator switch is used to set a Slave as the terminator in Wired Systems, and should only be turned ON for the last Slave connected in series to the Master. Press up on the switch to turn it ON and designate the Slave as a terminator. When the System is turned on, the Master checks to be sure that a terminator has been designated. If it finds a terminator, the Master determines that the SYSMAC BUS/2 transmission path has been established. In Wired Systems, you must set one (and only one) terminator for each Master. If there is no terminator set, or if there are two or more terminators set, data will not be transmitted.

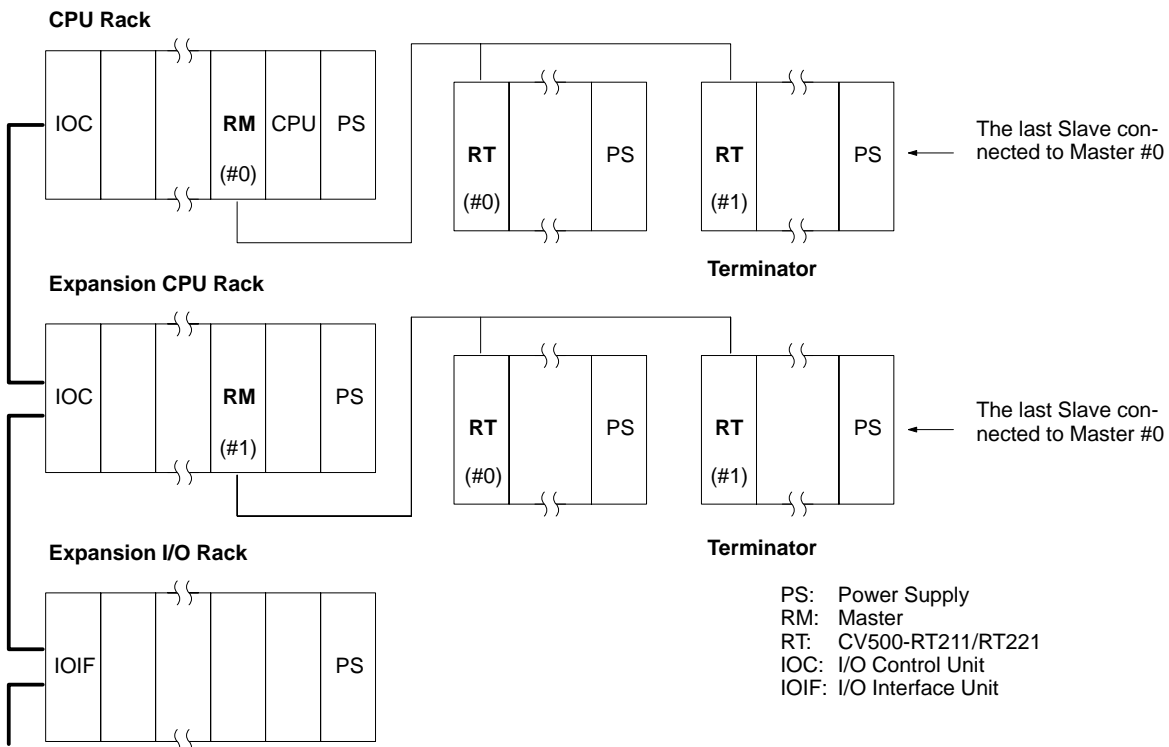

DIP Switch

The DIP switch sets the operating parameters for the CV500-RT211/RT221. The settings are described in the following tables.

| Pin | Setting | Function |
|-----|---------|--|
| 6 | ON/OFF | Sets the type of Master (see below). |
| 5 | | |
| 4 | ON/OFF | Output status for transmission errors ON: Retain current status; OFF: Turn OFF all outputs. |
| 3 | OFF | Set to Always OFF. |
| 2 | OFF | Sets the baud rate for the Peripheral Device connected to the Slave (see below). |
| 1 | | |

| Pin 5 | Pin 6 | Slave type | Remarks |
|-------|-------|------------|---|
| OFF | OFF | 58M | Up to 29 input words and 29 output words. |
| OFF | ON | 122M | Up to 61 input words and 61 output words. |
| ON | OFF | 54MH | Up to 27 input words and 27 output words |
| ON | ON | Not used. | |

Note Even if communications are stopped at the Master or a Slave is disconnected, the Slave's outputs will be handled according to the setting of DIP switch pin 4. If a non-transmission error occurs, such as an I/O bus error at the Slave, outputs will be turned OFF regardless of the setting of pin 4. If there is a communications error, input data will be retained at the CPU.

Baud Rate

The baud rate is set with pins 1 and 2. When the CVSS is connected, the baud rate must be set to the same speed as that set for the CVSS.

| DIP switch | 4.8K bps | 9.6K bps | 19.2K bps | 50K bps |
|------------|----------|----------|-----------|---------|
| Pin 1 | ON | OFF | ON | OFF |
| Pin 2 | ON | ON | OFF | OFF |

4-4 Unit Settings

Unit settings are kept in the CPU memory for the CPU Bus Units. The settings in this area for the SYSMAC BUS/2 are shown below. The unit settings can be changed from the CVSS. For details on changing settings, refer to *Communications Unit Settings* in the *CVSS Operation Manual: Online*. After changing the settings, restart the system by turning the power off and then on again.

| Item | Setting |
|---------------------------------|-----------------------|
| Hardware check | Yes/No |
| Communications error processing | Stop/Continue |
| Error check | Continuous/Cumulative |
| Communications cycle time | 5 to 32 ms |
| Transmission error count | 1 to 255 |
| Response monitoring time | 10 to 2,550 ms |

Hardware Check

Each time a Master is turned on, it can perform a hardware check on itself. The hardware check settings are as follows:

Yes: Hardware check performed

No: Hardware check not performed

When the hardware check is performed, there is a time lapse before the System sets up. Any errors in the Unit can be discovered during that time.

Communications Error Processing

In the event of a transmission error, communications can be stopped at the point where the error occurred. The settings are as follows:

Don't stop: Continue communications in the event of an error

Stop: Discontinue communications in the event of an error

In order to resume communications after they have been stopped due to an error, you must perform either of the following operations:

- 1, 2, 3... 1. Clear the error from the CVSS.
2. Turn ON the Communications Error Clear Bit [bit 14 of CIO 1500 + (25 x unit number)].

Caution For loop connections in an Optical System, do not set the Unit to stop communications in the event of a transmission error. If communications are set to stop, then the backup loop (sub-loop) will not operate when an error occurs.

Note If communications are set to stop when an error occurs, then when a transmission error such as a cable disconnection occurs, the error bit in the Auxiliary Area will turn ON for the Unit that was communicating at the time of the error and not necessarily the Unit where the cable was disconnected. Furthermore, communications will not begin if there is a Slave which is not powered up.

Error Check

The error check can be either cumulative or continuous. Also see *Transmission Error Count*, below.

Cumulative Error Check

The number of CRC errors is counted for each Slave and an error is generated when the number exceeds the number which has been set. By clearing the remote error log from the CVSS, the counter is set to 0.

Continuous Error Check

The number of CRC errors is counted for each Slave and an error is generated if the CRC errors continue continuously until the set number is reached. If there is one normal transmission during the CRC error count, the count will be reset to 0 at that point.

Communications Cycle Time

For normal communications between the Master and a Slave, the communications cycle time can be set within a range of 5 to 32 ms. The time is set in units of 1 ms. If the cycle time is set to less than 5 ms, then it will be considered to be set to 5 ms. Likewise, if the cycle time is set to more than 32 ms, then it will be considered to be set to 32 ms. The default setting is 5 ms. If the set communications cycle time is shorter than the actual communications cycle time, then the set time will be exceeded and the communications cycle will be completed.

Example 1: If the actual communications cycle time is 10 ms and the communications cycle time is set to 5 ms, the communications cycle time will be 10 ms.

Example 2: If the actual communications cycle time is 10 ms and the communications cycle time is set to 15 ms, the communications cycle time will be 15 ms.

Example 3: If the actual communications cycle time is 10 ms and the communications cycle time is set to 100 ms, the communications cycle time will be 32 ms.

Calculating the Communications Cycle Time

The communications cycle time equals the sum of the communications times for all of the Slaves connected to the Master. The following table shows the time required for each Slave.

| Slaves | Wired | Optical |
|---------------------|---------------|---------------|
| Group-1 Slaves | 0.16 ms/Slave | 0.32 ms/Slave |
| Group-2 Slaves | 0.31 ms/Slave | 0.47 ms/Slave |
| Group-3 Slaves 58M | 1.25 ms/Slave | 1.89 ms/Slave |
| Group-3 Slaves 54MH | 2.5 ms/Slave | 4.5 ms/Slave |
| Group-3 Slaves 122M | 2.5 ms/Slave | 4.5 ms/Slave |

Note The cycle time is temporarily extended when stopping and restarting Slaves after a transmission error.

Example

Group-1 Slaves: 5
 Group-2 Slaves: 3
 Group-3 Slaves (58M): 2
 Group-3 Slaves (122M): 1

Wired System

| | |
|--------------|-----------|
| 0.16 ms x 5 | (Group 1) |
| 0.31 ms x 3 | (Group 2) |
| 1.25 ms x 2 | (58M) |
| + 2.5 ms x 1 | (122M) |
| <hr/> | |
| 6.73 ms | A 7 ms |

The desired communications cycle time should thus be set between 7 and 32 ms.

Optical System

| | |
|--------------|-----------|
| 0.32 ms x 5 | (Group 1) |
| 0.47 ms x 3 | (Group 2) |
| 1.89 ms x 2 | (58M) |
| + 4.5 ms x 1 | (122M) |
| <hr/> | |
| 11.29 ms | A 12 ms |

The desired communications cycle time should thus be set between 12 and 32 ms.

Transmission Error Count

The number of transmission errors can be set within a range of 1 to 255. This count is used by the error check to determine when an error should be generated.

Response Monitoring Time

The response monitoring time is set in units of 1 ms within a range of 10 ms to 2,550 ms. If a response indicating that a command was received is not returned within the set time, then a time-out error will be generated. This does not mean that the command is necessarily executed within the response monitoring time. A time-out error will be generated if the time is smaller than the communications cycle time. The default setting is 2,550 ms.

SECTION 5

Operation

This section describes operational aspect of Remote I/O Systems that are relevant most after the System has started operation. Some information, such as programming user messages on the 7-segment displays provided on Remote I/O Slave Units, also needs to be considered in preparing for operation and writing the user program for the PC.

| | | |
|-------|---|----|
| 5-1 | Overview | 54 |
| 5-2 | 7-Segment Display | 54 |
| 5-3 | CPU Bus Unit Area Operations | 57 |
| 5-3-1 | Operating Status Words | 58 |
| 5-3-2 | Control Switch Word | 62 |
| 5-3-3 | Stopping and Restarting Slave Communications | 63 |
| 5-3-4 | Stopping and Restarting Master Communications | 64 |
| 5-3-5 | Communications Tests | 66 |







5-1 Overview

The following tables provides an overview of the operations covered in this section.

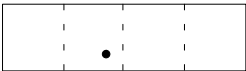
| Function | Function | Purpose | Section |
|--------------------------------|--|------------------------------------|---------|
| 7-segment display (Slave Rack) | See below. | System maintenance/troubleshooting | 5-2 |
| Reading operating status | Readout the status of Masters, Slaves, and transmission paths. | Error detection | 5-3-1 |
| Stopping/restarting Slaves | Stopping and restarting of Slaves during communications. | Troubleshooting | 5-3-3 |
| Stopping/restarting Masters | Stopping and restarting of Masters during communications. | Troubleshooting | 5-3-4 |
| Communications tests | Testing of communications between a Master and any Slave. | System maintenance | 5-3-5 |

5-2 7-Segment Display

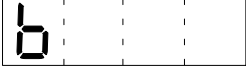
The CV500-RT211/RT221 are equipped with a 7-segment display that can be switched between various display modes, as shown in the following table.

| Display mode | Display format | Function | Page |
|-------------------|---|---|------|
| Mode 1 |  | Displays the address of the first word allocated on the Slave Rack. | 55 |
| Mode 2 |  | Displays PC status, the Master number, and the Slave Unit number. | 55 |
| Mode 3 |  | Displays characters, contents, and conditions set from the user program. | 56 |
| Mode 4 |  | Reserved for future use. | 56 |
| Error Display |  | Displays error messages. | 56 |
| Baud Rate Display |  | Displays the baud rate set for communications with the Peripheral Device. | 57 |
| Switch Readout |  | Displays the terminator designation and Slave unit number. | 57 |

Changing Display Modes

Switch Readout

If the display mode switch is pressed and held before the System has started (when “—” is displayed), the switch settings will be displayed.

Modes 1, 2, 3, and 4

After the System has started, the 7-segment display will start in display mode 1. The mode can be changed in order (from mode 1 through mode 4, and then back to mode 1) by pressing the display mode switch.

Error Messages and Baud Rate Display

After the System has started, the display mode will automatically change when an error occurs or when a Peripheral Device is connected.

When an error occurs, an error message will appear. When the error has been cleared or when the display mode switch is pressed, the display will return to the mode that was displayed prior to the error.

When a Peripheral Device is connected, the baud rate set for communications with the Peripheral Device will be displayed. The baud rate will be displayed for

2 seconds, and then the display will return to the mode that was displayed before the Peripheral Device was connected.

Note The order in which the modes change (i.e., mode 1, mode 2, mode 3, etc.) is fixed, but the initial mode at startup can be set in the PC Setup from a Peripheral Device. Refer to the *CVSS Operation Manual: Offline* for details.

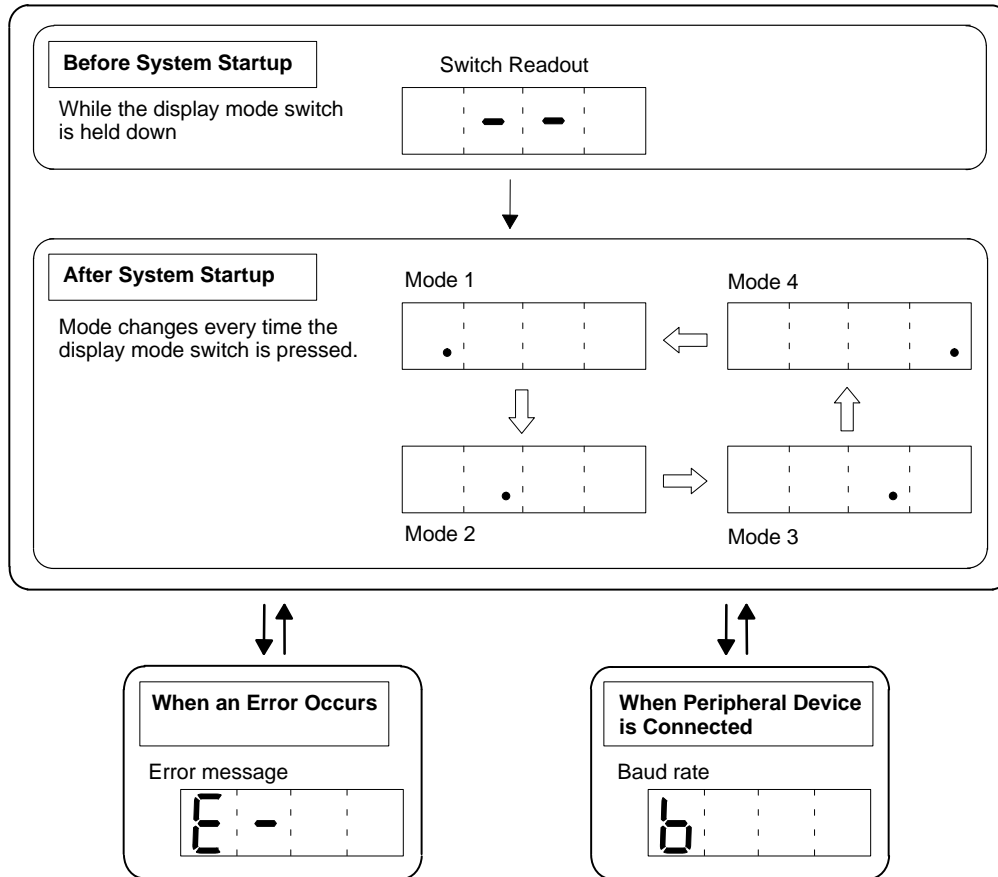

Examples

Mode 1

In mode 1, the first word allocated on the Slave Rack is displayed. While mode 1 is being displayed, a dot will be lit at the bottom of the leftmost digit of the display.

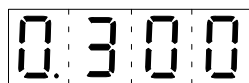

CIO 0300
Indicates that the first word on the Slave Rack is CIO 0300.

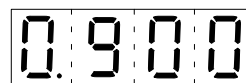

CIO 0900
Indicates that the first word on the Slave Rack is CIO 0900.

Mode 2

In mode 2, the status of the PC controlling the Slave, the master number of the Master to which the Slave is connected, and the Slave unit number are dis-

played. While mode 2 is being displayed, a dot will be lit at the bottom of the second digit from the left.

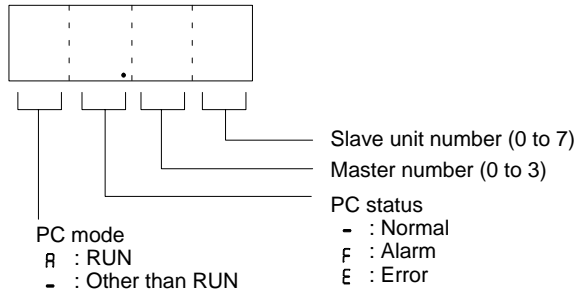

PC: RUN, Normal
 Master: &0
 Slave: #7



PC: Other than RUN, Normal
 Master: &1
 Slave: #6



PC: RUN, Alarm
 Master: &2
 Slave: #5



PC: Other than RUN, Error
 Master: &3
 Slave: #4

Mode 3

In mode 3, the display conditions and characters are set via the user program. While mode 3 is being displayed, a dot will be lit at the bottom of the third digit of the display. An example of a user program for 7-segment display is given in 7-2 *User Program for 7-Segment Display*.

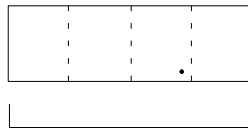

Generated in user program

Mode 4

Mode 4 is not currently used and is reserved for future use. Nothing is displayed except for the dot at the bottom of the rightmost digit.



Error Display

When an error occurs, the error indicator mark "E-" and the error code will flash on the display. When the cause of the error is eliminated or when the display mode switch is pressed, the display will return to the mode that was being displayed before the error occurred. For details, refer to *Section 8 Troubleshooting*.

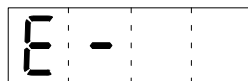

Fixed Error code

- Note**
1. Depending on the type of error, the display may not return to the mode that was being displayed prior to the error until the error has been cleared.
 2. Error determination is made by the Slave, so the Slave's error display may not match that of the Master.

Baud Rate Display

When a Peripheral Device is connected, the baud rate that has been set in the Slave for communications with the Peripheral Device will be displayed for approximately 2 seconds. For details on baud rates, refer to 4-3 *Other Switch Settings*.



4.8K bps



9.6K bps



19.2K bps



50K bps

Switch Readout

Pressing the display mode switch during initial processing before the System starts operation will produce a display telling whether or not the Slave has been designated as a terminator and the Slave's unit number.

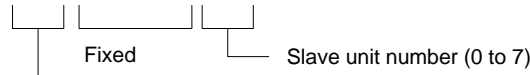
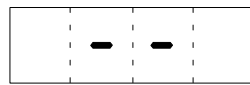

Terminator designation
 L : Terminator
 = : Not terminator

5-3 CPU Bus Unit Area Operations

CPU Bus Unit Area addresses range from CIO 1500 through CIO 1899. These 400 words are divided into 16 groups of 25 words each. These words are allocated to CPU Bus Units according their unit number settings as shown in the following tables.

| Unit # | 0 | 1 | 2 | 3 | 4 | 5 | 6 | 7 |
|------------------|--------------|--------------|--------------|--------------|--------------|--------------|--------------|--------------|
| CIO words | 1500 to 1524 | 1525 to 1549 | 1550 to 1574 | 1575 to 1599 | 1600 to 1624 | 1625 to 1649 | 1650 to 1674 | 1675 to 1699 |

| Unit # | 8 | 9 | 10 | 11 | 12 | 13 | 14 | 15 |
|------------------|--------------|--------------|--------------|--------------|--------------|--------------|--------------|--------------|
| CIO words | 1700 to 1724 | 1725 to 1749 | 1750 to 1774 | 1775 to 1799 | 1800 to 1824 | 1825 to 1849 | 1850 to 1874 | 1875 to 1899 |

Each SYSMAC BUS/2 Master (i.e., CV500-RM211/RM221) uses the words allocated to it as shown in the following table. The first 6 words are used to control Slave operation by manipulating the status of these 6 words from the user program or from a Peripheral Device. The last 19 words can be read out from the program or a Peripheral Device to access information on the status of the Remote I/O System.

The first word allocated to each Master can be calculated by adding 1500 to 25 times the unit number of the Master. In this section, words are indicated using this notation. For example, the second word allocated to the Master assigned unit number 5 would be 1500 + (25 x 5) + 1, or 1626. The third through fifth words for unit number 8 would be 1500 + (25 x 8) + (2 to 5), or 1702 to 1705.

| Words | Item | Function | Page |
|---|---|---|------------------------------|
| 1 word 1500 + (25 x No.) | Control Switches | Stopping or starting communications. Restarting communications after errors. Starting communications test. Stopping/restarting Slave communications. Restarting group-3 Slaves. | 64 101 66 63 101 |
| 1 word 1500 + (25 x No.) + 1 | Communications Test | Controlling Master/Slave communications test. | 66 |
| 4 words 1500 + (25 x No.) + (2 to 5) | Slave Communications Stop/Restart | Controlling Slave communications. | 63 |
| 1 word 1500 + (25 x No.) + 6 | Remote Status | Slave I/O errors Master errors Transmission path status Communications status | 58 |
| 1 word 1500 + (25 x No.) + 7 | Wired Systems: Terminator Status Optical Systems: Transmission Path Status | Wired Systems: Terminator setting Unit number of terminator Optical Systems: Transmission path status | 59 60 |
| 1 word 1500 + (25 x No.) + 8 | Communications Test Results | Readout of communications test results. | 66 |
| 4 words 1500 + (25 x No.) + (9 to 12) | Active Slave Status | Readout of Slaves currently active in System. | 60 |
| 4 words 1500 + (25 x No.) + (13 to 16) | RUN/Maintenance Status | Readout of Slave status. | 61 |
| 4 words 1500 + (25 x No.) + (17 to 20) | Applications Errors | Readout of Slaves with applications errors. | 61 |
| 4 words 1500 + (25 x No.) + (21 to 24) | Transmission Errors | Readout of Slaves with transmission errors. | 62 |

5-3-1 Operating Status Words

The following four words indicate the operating status of Masters and Slaves.

- Remote Status
- Terminator Status and Transmission Path Status
- Communications Test Results
- Master Status

For details on the Communications Test Results, refer to 5-3-5 *Communications Tests*.

Remote Status

The Remote Status word shows the status of the following. The status of the bits in the Remote Status word can be read to access the status shown below.

- System configuration errors
- Slave I/O errors
- Master errors
- Transmission path status
- Communications status

For details on transmission path status, refer to 8-5 *Transmission Path Backup*.

The Remote Status word is CIO 1500 + (25 x unit number) + 6.

Optical Systems

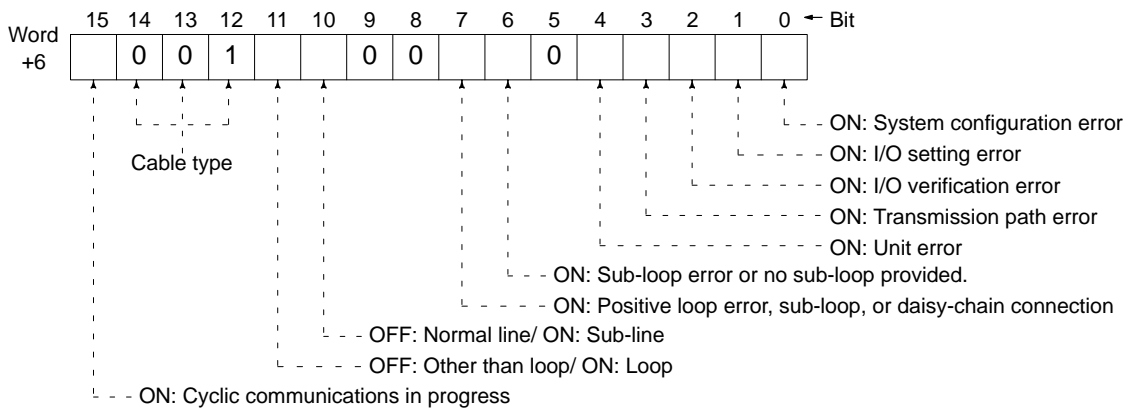

Wired Systems

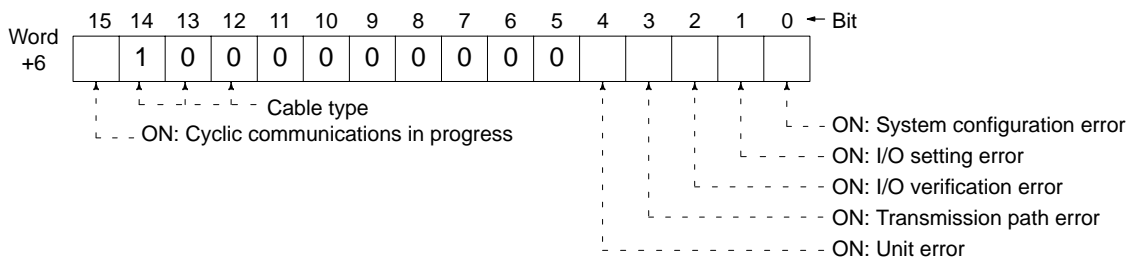

Bits 12 to 14: Cable Type

| Bit | | | Cable |
|-----|----|----|---------------|
| 14 | 13 | 12 | |
| 0 | 0 | 1 | Optical fiber |
| 1 | 0 | 0 | Wire |

Bits 6, 7, 10, and 11

Refer to 8-5 Transmission Path Backup.

Terminator Status and Transmission Path Status

Terminator Status

In Wired Systems, the 8th word is used as the Terminator Status word. This word shows whether a terminator has been correctly set, and gives the group and number of the Slave set as the terminator.

The Terminator Status word is CIO 1500 + (25 x unit number) + 7.

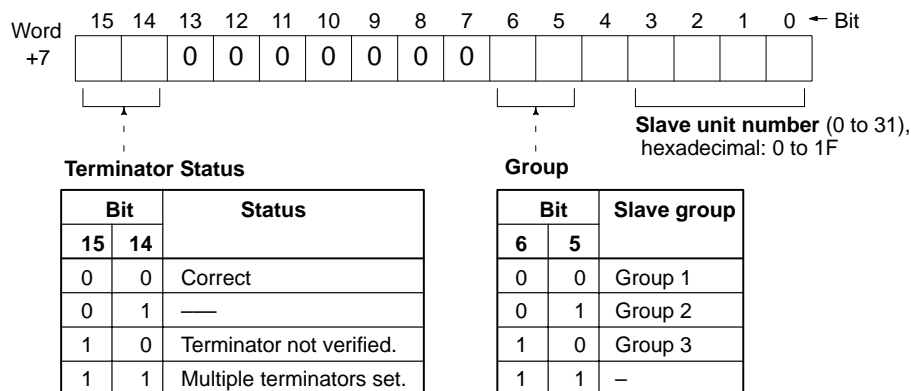

Bits 0 to 4: Slave Unit Number

These bits indicate the Slave unit number of the Slave that has been

set as the terminator. If a terminator has not been correctly set, the data will be undependable.

Bits 5, 6: Slave Group

If a terminator has been correctly set, the Slave group will be indicated. (CV500-RT211 and CV500-RT221 Slaves belong to group 3.) If a terminator has not been correctly set, the data will be undependable.

Bits 14, 15: Terminator Status

These bits indicate whether a terminator has been correctly set.

Transmission Path Status

In Optical Systems, this word is used as the Transmission Path Status word. This word shows the mode of the transmission path. For details, refer to 8-5 *Transmission Path Backup*.

The Transmission Path Status word is CIO 1500 + (25 x unit number) + 7.

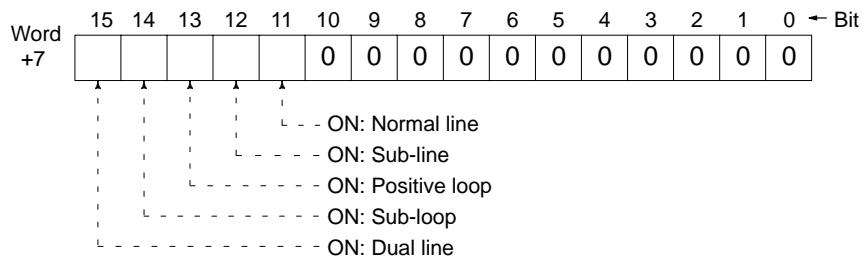

Slave Status Words

The Slave Status words show the operating status of each Slave, including the following:

- Slaves involved in communications.
- Slaves undergoing maintenance.
- Slaves with applications errors (e.g., I/O bus or watchdog timer errors)
- Slaves with transmission errors (i.e., transmission, response, or CRC errors)

There are four Slave Status regions, as shown in the following table, and each is allocated four words.

| Slave Status | |
|---------------------|-----------|
| Active Slaves | (4 words) |
| RUN/Maintenance | (4 words) |
| Applications Errors | (4 words) |
| Transmission Errors | (4 words) |

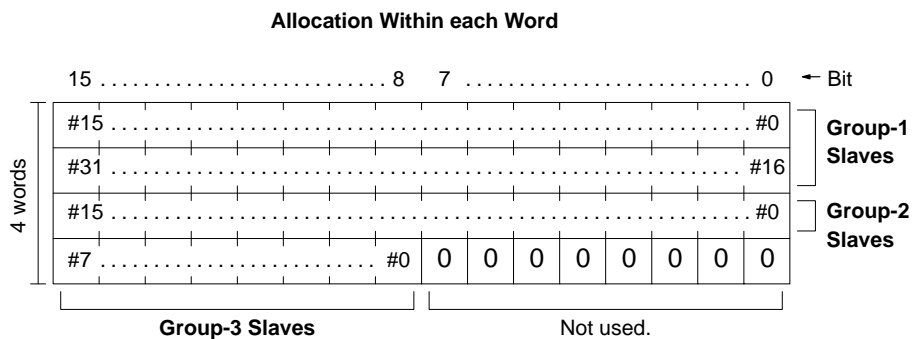

Active Slave Status

These words indicate whether Slaves are active in the SYSMAC BUS/2 System. Slaves registered in the I/O table are considered active unless communications to them have been stopped. If a bit is ON, the Slave of the corresponding unit number and group is active.

The Active Slave Status words are CIO 1500 + (25 x unit number) + (9 to 12).

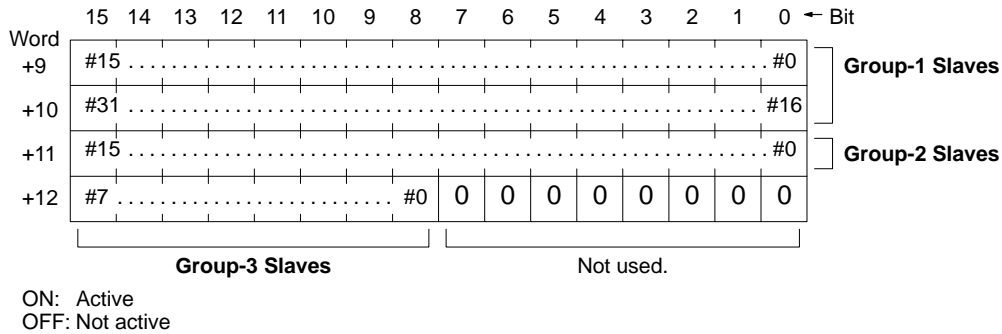

RUN/Maintenance Status These words show when the Slave is in RUN mode. If a bit is ON, the Slave of the corresponding unit number and group is operating. Depending on the type of Slave, there is also a Maintenance mode. When the Slave is in Maintenance mode, it cannot communicate and the bit for it will be OFF.

The RUN/Maintenance Status words are
CIO 1500 + (25 x unit number) + (13 to 16).

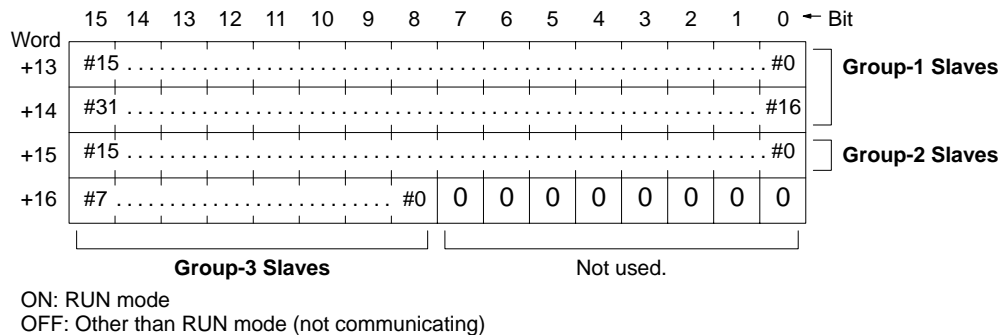

Slaves involved in normal communications are always in RUN mode. Use the following table to distinguish between Slaves in Maintenance mode and those that are not communicating.

| Status | Active Slave Status | RUN/Maintenance | Applications Errors | Transmission Errors | Remarks |
|--------------------------------------|---------------------|-----------------|---------------------|---------------------|-------------------------|
| Normal operation | Yes | Yes | No | No | — |
| Maintenance mode (note 1) | Yes | No | No | No | Communications normal. |
| Not communicating | No | No | No | No | Slave not in I/O table. |
| Slave does not exist | Yes | No | No | Yes | Slave in I/O table. |
| Transmission error | Yes | Yes | No | Yes | Error at Slave. |
| Applications error at Slave (note 2) | Yes | Yes | Yes | No | Communications normal. |

- Note**
1. When notification is received from a Slave that it has gone into Maintenance mode, the corresponding bit will turn ON. (The CV500-RT211 and CV500-RT221 do not have a Maintenance mode.)
 2. The definition of an applications error varies with different Slaves.

Applications Errors These words show applications errors at the Slave. If a bit is ON, an error has occurred in the Slave of the corresponding unit number and group. For details on the content of applications errors, refer to the operating manuals for the various Slaves. For the CV500-RT211 and CV500-RT221, applications errors are those such as I/O bus errors or a watchdog timer errors for which clearing the error does not cause an automatic recovery.

The Applications Error words are CIO 1500 + (25 x unit number) + (17 to 20).

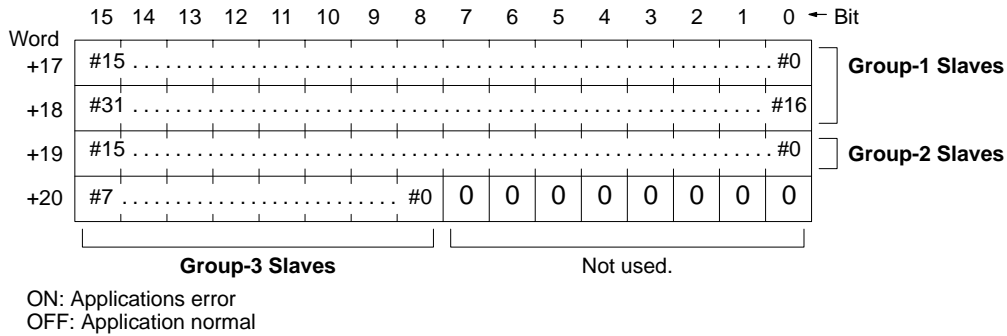

Transmission Errors

These words show errors in communications, i.e., CRC errors, response errors, and transmission path errors. When such errors occur the specified number of times, the bit of the corresponding unit number and group turns ON and communications stop. Refer to 4-4 Unit Settings for setting the transmission error count used to determine when a transmission error is to be generated.

The Transmission Error words are CIO 1500 + (25 x unit number) + (21 to 24).

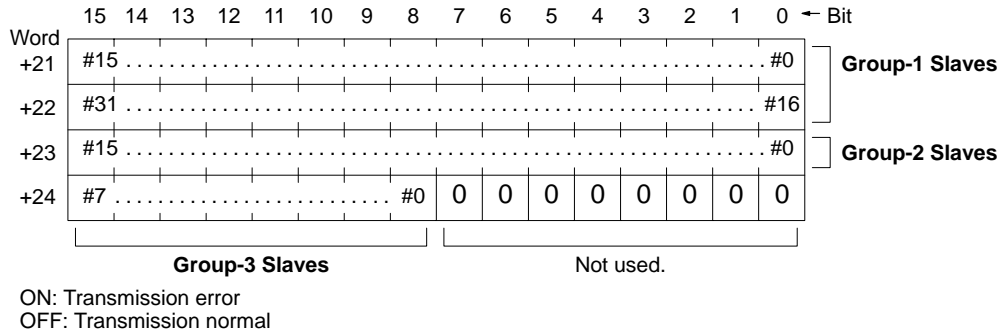

When communications are stopped for a Slave, the output data prior to the error is either retained or cleared, depending on the Data Retain/Clear setting. This setting is made with the DIP switch on the Slave. For details on retaining or clearing data for the CV500-RT211 and CV500-RT221, refer to 4-3 Other Switch Settings. For other Slaves, refer to the operation manual for the Slave.

5-3-2 Control Switch Word

Three bits are used in the Control Switch word (1500 + (25 x unit number)) to control Remote I/O System communications. The Master Stop/Restart Bit is turned ON to start or stop communications for the Masters. The Slave Stop/Restart Bit is turned ON to stop or restart communications for Slaves according to the contents of the Slave Communications Stop/Restart words. The Communications Test Start Bit is turned ON to start communications test for the Slave designated in the Communications Test word. The actual procedures for using these bits are provided in the following sections.

The Group-3 Restart Bits and Communications Error Clear Bit are described in Section 8 Troubleshooting.

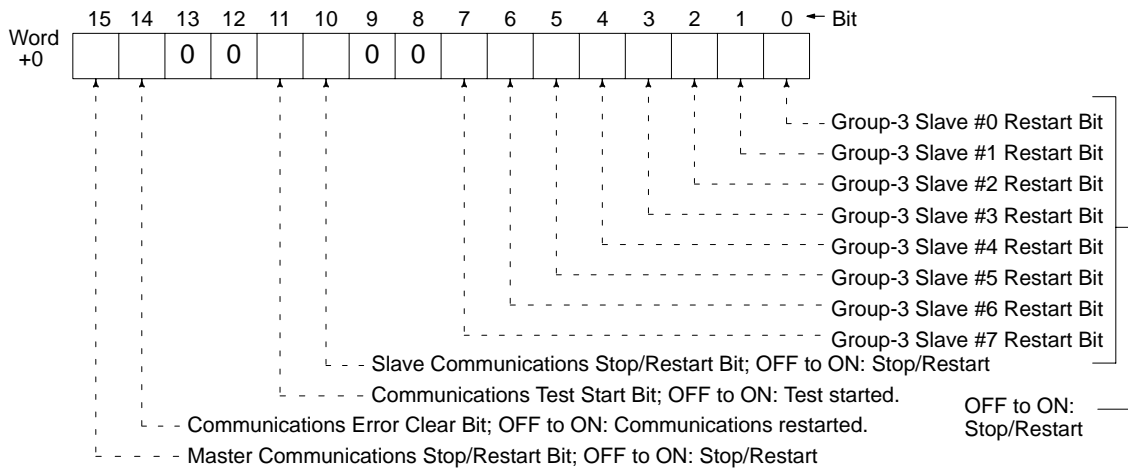

5-3-3 Stopping and Restarting Slave Communications

Slave communications can be stopped and restarted from a Peripheral Device, or from the user program by controlling the status of specified bits in the PC. For example, in the following system configuration, any or all of the Slaves in process A Slave can be removed from communications when an applications error occurs in any of the Slaves.

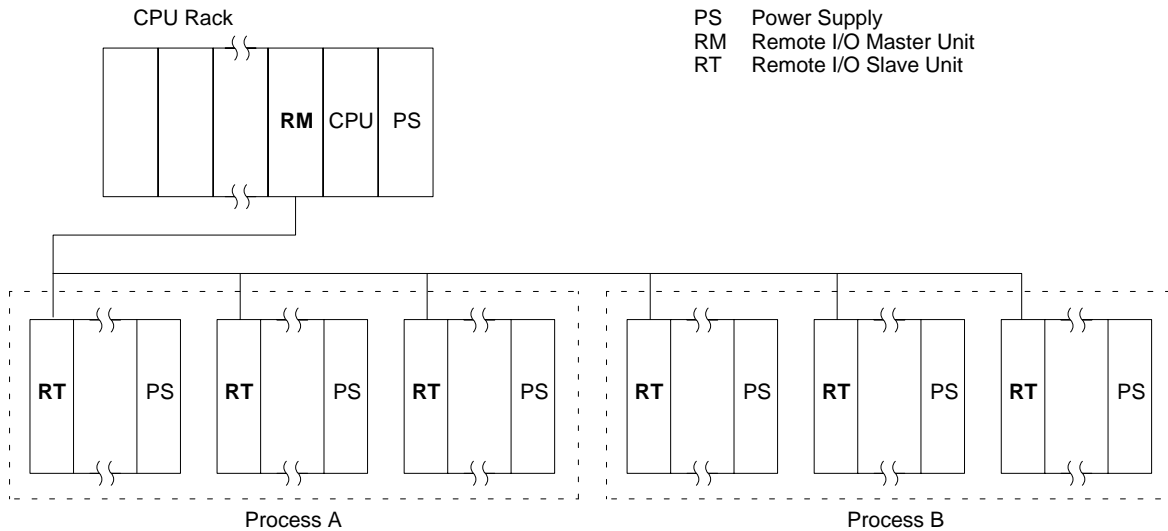

- Note**
1. Any Slaves involved in communications can have communications stopped, but only those Slaves registered in the I/O table can be restarted.
 2. Even if a Slave is removed from communications, the Peripheral Device connected to it will still operate.

The procedures for stopping and restarting communications are given below.

From Peripheral Device

Stopping Communications

- 1, 2, 3... 1. Connect the Peripheral Device to the Slave for which you want to stop communications or to the PC of the Master to which that Slave is connected.
2. Perform the operation for stopping communications given in the *CVSS Operation Manual: Offline*.
3. Verify that communications have stopped. The T/R indicator will go out on the Slaves for which communications have stopped.

Restarting Communications

- 1, 2, 3... 1. Connect the Peripheral Device to the Slave for which you want to restart communications or to the PC of the Master to which that Slave is connected.
2. Perform the operation for restarting communications given in the *CVSS Operation Manual: Offline*.
3. Verify that that communications have restarted and that there are no errors. The T/R indicator will light on the Slave for which communications have been restarted.

From User Program

This procedure manipulates the Control Switch and Slave Communications Stop/Restart words allocated to the Master.

- 1, 2, 3... 1. Turn ON the corresponding bit in the Slave Communications Stop/Restart words for each Slave that is to be restarted or for each Slave that is to continue communications and turn OFF the corresponding bit for each Slave for which communications are to be stopped. The bits in the Slave Communications Stop/Restart words are allocated according to Slave unit numbers as shown in the following diagram.

The Slave Communications Stop/Restart words are
 $CIO\ 1500 + (25 \times \text{unit number}) + (2\ \text{to}\ 5)$.

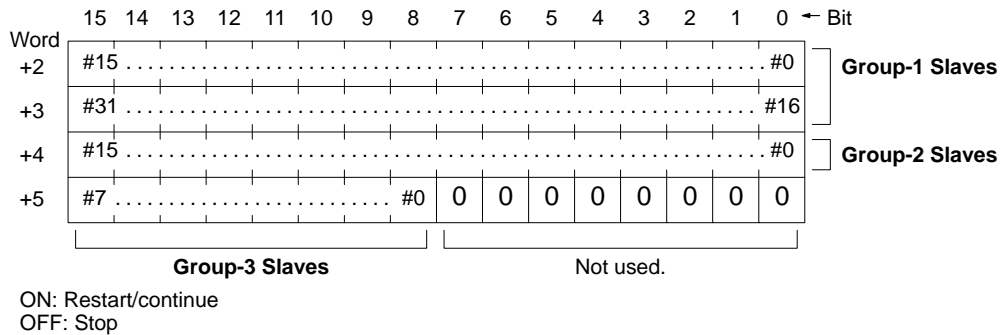

2. Turn ON the Slave Communications Stop/Restart Bit (bit 10) in the Control Switch word ($1500 + (25 \times \text{unit number})$).

For an example of a user program for stopping Slave communications, see 7-3 *User Program for Stopping Slave Communications*.

Note If the Slave Communications Stop/Restart Bit is turned ON without turning ON the desired bits in the Slave Communications Stop/Restart words, communications will be stopped for all Slaves. The ERT indicator will light on Slaves for which communications have stopped and E-15 will flash on the 7-segment display for the CV500-RT211 and CV500-RT221.

5-3-4 Stopping and Restarting Master Communications

A Master's data communications can be stopped and restarted by means of Peripheral Device operation or the user program. If a Master's communications are stopped, communications will also be stopped for all Slaves connected to that Master. For example, in the following system configuration, communications will be stopped for all of the Slaves in process A if communications are stopped for the Master to which they are connected. If an error occurs in any of the Slaves in

process A, communications can thus be stopped for only the Slaves in that process, without stopping communications for the Slaves in process B or C.

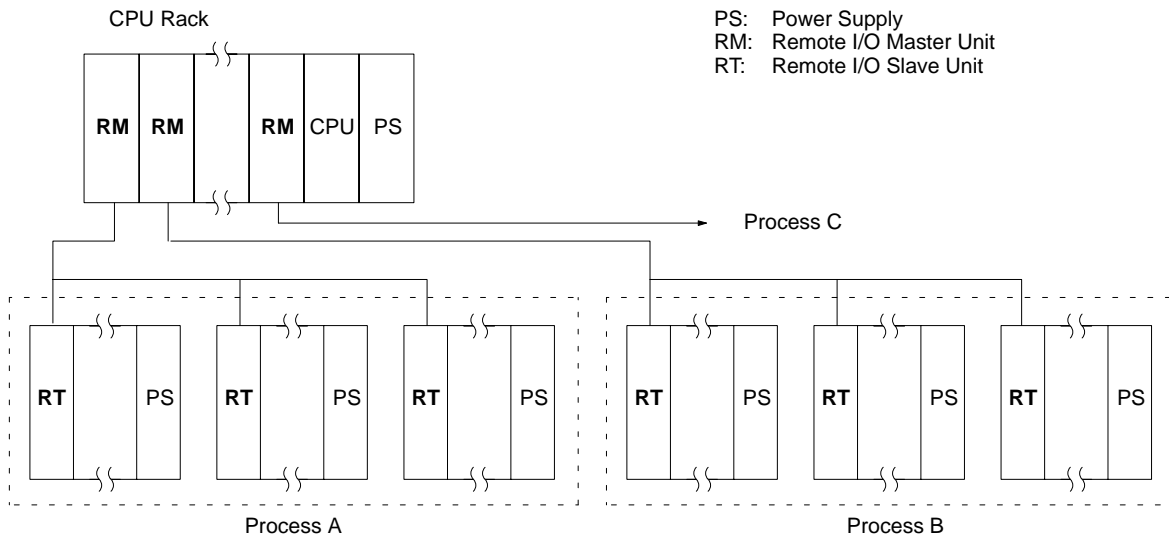

Note If communications are stopped for a particular Slave before communications are stopped for the Master, then communications will not be restarted for the Slave merely by restarting them for the Master, and the Slave will have to be restarting according to the procedure given in 5-3-3 *Stopping and Restarting Slave Communications*.

The procedures for stopping and restarting Master communications are as follows:

From Peripheral Device

Stopping Communications

- 1, 2, 3... 1. Connect the Peripheral Device to the PC of the Master for which you want to stop communications.
2. With the Peripheral Device, specify the Master for which you want to stop communications.
3. Verify that the SD indicator has gone off for the Master.
4. When you have verified that the SD indicator has gone off, then the operation is complete.

Restarting Communications

- 1, 2, 3... 1. Connect the Peripheral Device to the PC of the Master for which you want to restart communications.
2. With the Peripheral Device, specify the Master for which you want to restart communications.
3. Verify that the SD indicator has gone back on for the Master.
4. When you have verified that the SD indicator has lit, then the operation is complete.

For instructions on using the Peripheral Device, refer to the *CVSS Operation Mnaual: Online*.

From User Program

This procedure manipulates the Control Switch word allocated to the Master.

Stopping Communications

- 1, 2, 3... 1. Turn ON the Master Communications Stop/Restart Bit (bit 15) in the Control Switch word (1500 + (25 x unit number)). If Master communications were enabled, they will be stopped.
2. Verify that the SD indicator on the Master has gone off. Bit 15 of the Remote Status word (CIO 1500 + (25 x unit number) +6) should turn OFF.

For an example of a user program for stopping Master communications, refer to *7-4 User Program for Stopping Master Communications*.

Restarting Communications

- 1, 2, 3... 1. Turn ON the Master Communications Stop/Restart Bit (bit 15) in the Control Switch word (1500 + (25 x unit number)). If Master communications had previously been stopped, they will be restarted.
2. Verify that the SD indicator on the Master has lit. Bit 15 of the Remote Status word (CIO 1500 + (25 x unit number) +6) should turn ON.

5-3-5 Communications Tests

Transmission paths between Masters and Slaves can be tested. In the transmission path test, data is sent from a Master to a Slave, and then the same data is sent back and compared to the original data. The test is executed a set number of times. The test results can be checked by means of the TS indicator on the Master and by reading out the test results.

Note If a test is executed during event data communications, the event communications will be delayed.

A communications test can be executed either from the user program or a Peripheral Device. The methods for executing the test are described below.

Starting a Test

A communications test is initiated with the Communications Test and Control Switch words allocated to the Master.

- 1, 2, 3... 1. Set into the Communications Test word the number of times the test is to be executed and the group and number of the Slave for which the test is to be made.

The Communications Test word is CIO 1500 + (25 x unit number) +1.

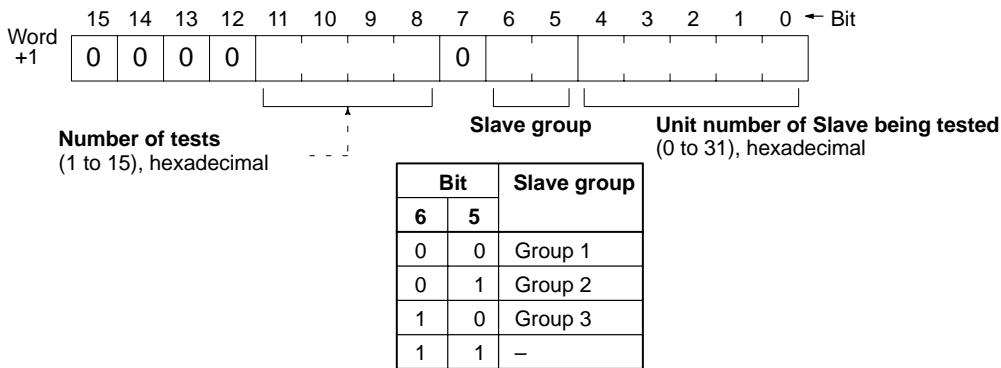

2. Turn ON the Start Communications Test Bit (bit 11) in the Control Switch word (1500 + (25 x unit number)).
3. Verify that the TS indicator on the Master has lit.

Reading Test Results

After the test has been completed, the Test Result word allocated to the Master can be read from a Peripheral Device or from the user program.

The Test Result words are CIO 1500 + (25 x unit number) + 8.

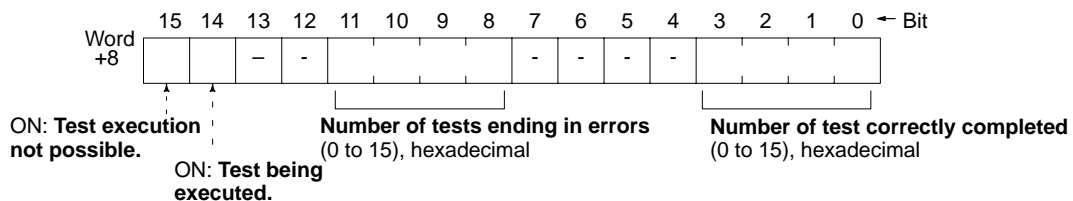

For instructions on using the Peripheral Device, refer to the *CVSS Operation Manual: Online*.

TS Indicator

Test results can also be read by means of the TS indicator on the Master. The following table shows the meaning of each indicator status.

| Lit | Flashing | Not lit |
|----------------------|--------------------------|-------------------------|
| Test being executed. | Test completed in error. | Test complete normally. |

- Note**
1. After the Start Communications Test Bit turns ON, wait at least 2 seconds and confirm that the Test Bit (bit 14) has turned OFF. Then read the test results.
 2. The data in the Test Results word will be retained until the next test is executed. If this word has not been set for retention, however, the data will be cleared when the mode is changed.
 3. If you attempt to execute the test for a non-existent Slave, the TS indicator will flash to show that the test has been completed and that there is an error.
 4. Do not manipulate the Start Communications Test Bit while the test is in progress.

SECTION 6

I/O Delays

This section describes how to compute the delay that occurs between receiving an input signal into a Remote I/O System and producing an output from the Remote I/O System. Refer to the *CV-series PC Operation Manual: Ladder Diagrams* for details on program execution and normal I/O delays.

Configuration and Program

The following system and instruction line will be used to demonstrate calculating the I/O delay, i.e., the time required for an output to be produced in response to an input signal. The input and output are both assumed to be on the Slave Rack shown in the following system.

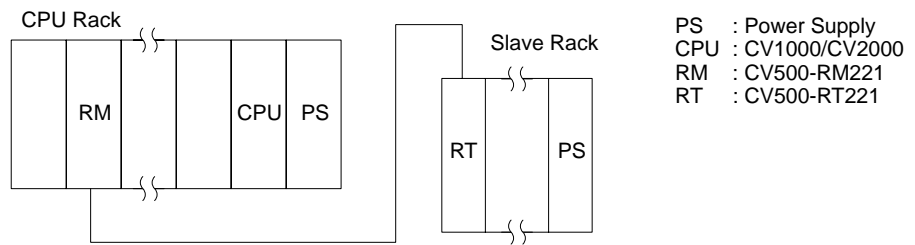

Calculations

The I/O delay depends on whether the PC has been set to use synchronous or asynchronous execution. Refer to the *CV-series PC Operation Manual: Ladder Diagrams* for details on PC operation.

Synchronous Execution

When synchronous execution is used, the PC refreshes remote I/O only once per cycle. After the Master transfers data to the CPU, it has to wait until the next I/O refresh period before the data is processed and a response is received. The factors that determined the I/O delay include the types of input and output being used, the cycle time, and when in the execution cycle the input signal is received. The minimum and maximum delays can be calculated as follows:

Minimum Delay

$$\begin{aligned} \text{Minimum delay} = & \text{input ON delay} \\ & + \text{communications cycle time} \times 5 \\ & + \text{PC cycle time} \times 2 \\ & + \text{output ON delay} \end{aligned}$$

Maximum Delay

$$\begin{aligned} \text{Maximum delay} = & \text{input ON delay} \\ & + \text{communications cycle time} \times 7 \\ & + \text{PC cycle time} \times 3 \\ & + 10 \text{ ms} \\ & + \text{output ON delay} \end{aligned}$$

Calculation Example

| | |
|----------------------------|--|
| Input ON delay: | 1.5 ms |
| Output ON delay: | 1.5 ms |
| Communications cycle time: | 5 ms (For 58M droup-3 Slave) |
| PC cycle time: | 20 ms |
| Minimum delay = | $1.5 + (5 \times 5) + (20 \times 2) + 1.5 = 68 \text{ ms}$ |
| Maximum delay = | $1.5 + (5 \times 7) + (20 \times 3) + 10 + 1.5 = 108 \text{ ms}$ |

Asynchronous Execution

When asynchronous execution is used, the PC refreshes remote I/O at the interrupt time during each SYSMAC BUS/2 communications cycle, thus decreasing the delays as follows:

Minimum Delay

$$\begin{aligned} \text{Minimum delay} = & \text{input ON delay} \\ & + \text{communications cycle time} \times 6 \\ & + \text{remote refresh time} \\ & + \text{output ON delay} \end{aligned}$$

Maximum Delay

$$\begin{aligned} \text{I/O maximum delay} = & \text{input ON delay} \\ & + \text{communications cycle time} \times 8 \\ & + \text{PC cycle time} \\ & + \text{remote refresh time} \\ & + 15 \text{ ms} \\ & + \text{output ON delay} \end{aligned}$$

Calculation Example

Input ON delay: 1.5 ms
 Output ON delay: 1.5 ms
 Communications cycle time: 5 ms (For one 58M group-3 Slave)
 PC cycle time: 20 ms
 Remote refresh time: 2 ms

$$\begin{aligned} \text{Minimum delay} &= 1.5 + (5 \times 6) + 20 + 1.5 = 35 \text{ ms} \\ \text{Maximum delay} &= 1.5 + (5 \times 8) + 20 + 2.0 + 15 + 1.5 = 80 \text{ ms} \end{aligned}$$

Remote Refresh Time

$$\text{Remote refresh time} = (\text{number of refresh words} \times 000.1) + 2.0 \text{ ms}$$

Communications Cycle Time

The communication cycle time for a Master equals the sum of the communications times for all of the Slaves connected to the Master.

If the communications cycle time setting is shorter than the actual communications cycle time, then the setting will be ignored and normal communications completed. If the communications cycle time which is calculated as described above comes to less than 5 ms, then it will be 5 ms, i.e., the minimum cycle time.

Communications Cycle Time per Slave

| Slave | Wired | Optical |
|---------------------|---------------|---------------|
| Group-1 Slaves | 0.16 ms/Slave | 0.32 ms/Slave |
| Group-2 Slaves | 0.31 ms/Slave | 0.47 ms/Slave |
| Group-3 Slaves 58M | 1.25 ms/Slave | 1.89 ms/Slave |
| Group-3 Slaves 54MH | 2.5 ms/Slave | 4.5 ms/Slave |
| Group-3 Slaves 122M | 2.5 ms/Slave | 4.5 ms/Slave |

Note The rough calculation method described here is used when Masters are the only CPU Bus Units connected to the PC. If there are other CPU Bus Units mounted, then you must use the following formula:

$$\left(\begin{array}{l} \text{Refreshing time of other} \\ \text{CPU Bus Unit} \end{array} + 1.5 \text{ ms} \right) * \text{Number of other CPU Bus Units}$$

This is a standard formula and assumes that nothing is executed with a higher priority than CPU Bus Unit refreshing. If, for example, instructions such as SEND(192) or RECV(193) are executed, then those instructions will be given higher priority and data processing time may be lengthened.

SECTION 7

Examples

This section provides an example of the steps required to set up and start operation of a Remote I/O System and then provides three examples of controlling operation from the user program. Refer to the *CV-series PC Operation Manual: Ladder Diagrams* for details on ladder-diagram programming.

| | | |
|-----|---|----|
| 7-1 | Remote I/O System Settings | 74 |
| 7-2 | User Program for 7-Segment Display | 76 |
| 7-3 | User Program for Stopping Slave Communications | 78 |
| 7-4 | User Program for Stopping Master Communications | 79 |

7-1 Remote I/O System Settings

The following example outlines the procedures used for SYSMAC BUS/2. Most of the operations performed must be performed from the CVSS.

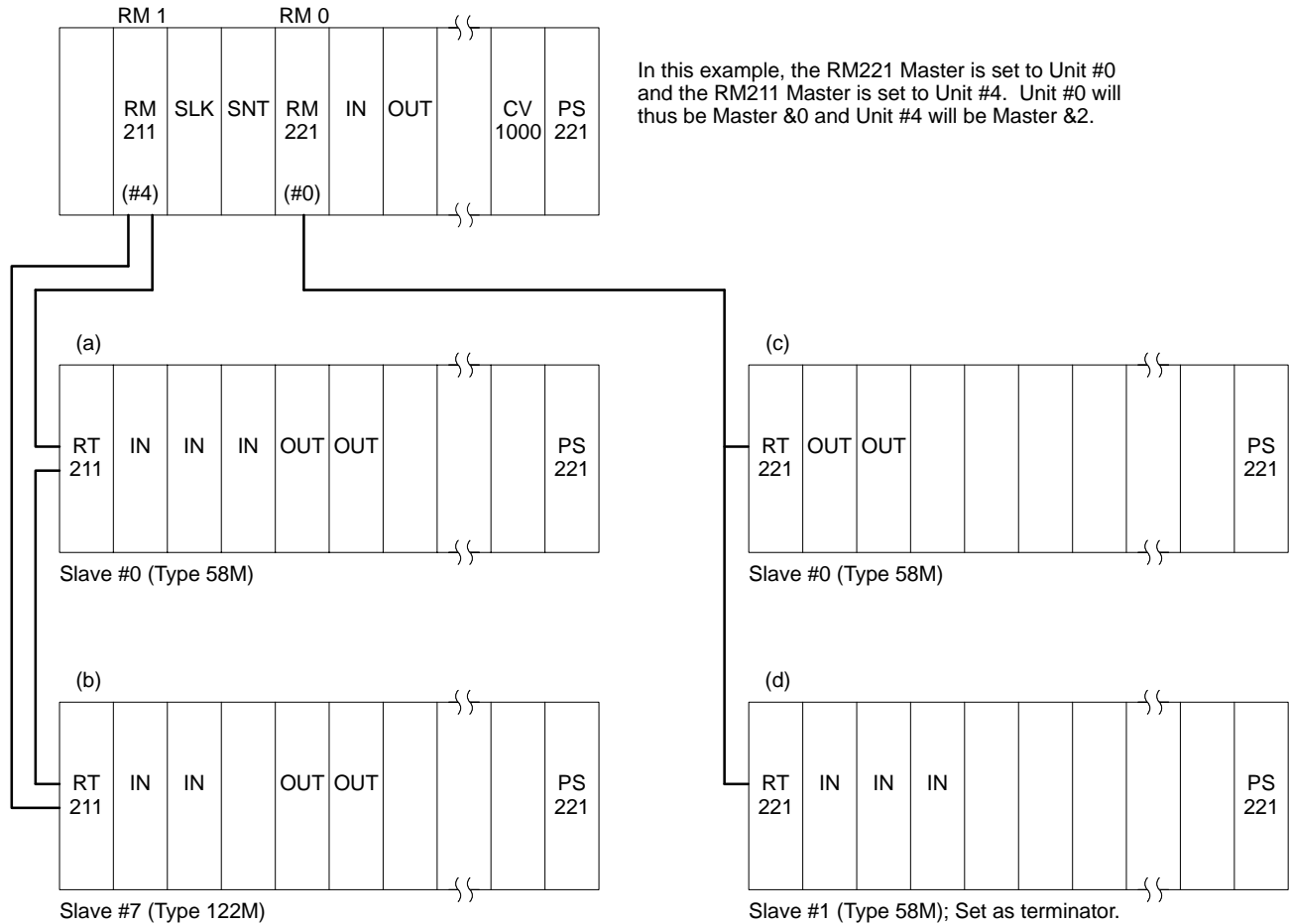

With the PC Setup, you can set the first word for each Rack. The words can be set within a range of CIO 0000 to CIO 0999, as long as they do not overlap words on other Racks. If nothing is set, the initial allocations for the above System will be as shown in the following table. The advantages of setting the first words shown in the *Setting example* column should be obvious in terms of managing word allocations.

| First word | Initial allocations | Setting example |
|------------|---------------------|-----------------|
| RT (a) | CIO 500 | CIO 100 |
| RT (b) | CIO 505 | CIO 200 |
| RT (c) | CIO 300 | CIO 300 |
| RT (d) | CIO 302 | CIO 400 |

Slave Switch Settings

The following settings are required for Slaves:

- Slave unit numbers (0 to 7)
- Slave types (DIP switches 5 and 6)
- Terminator (for last Slave in a Wired System)

In the configuration example, the Slave in Rack (d) is set as the terminator.

- Note**
1. If the same unit number is set for two or more Slaves, the System will not operate properly.
 2. In Wired Systems, the end Slave must be set as the terminator.

| | |
|-------------------------------|--|
| Slave Racks | The Power Supply (CV500-PS221), I/O Units, Special I/O Units, and Remote I/O Slave Unit (Optical or Wired) are mounted to a Backplane (CV500-BI112) and connected. |
| Master Switch Settings | Unit numbers for Masters are set from 0 to 15. In the configuration example, the RM221 Master is Unit #0 and the RM211 Master is Unit #4. Note The same unit number cannot be set for Master and another CPU Bus Unit. |
| PC Settings | The PC baud rate must be set on the DIP switch. |
| CPU Rack | The Power Supply (CV500-PS221), I/O Units, Special I/O Units, Remote I/O Master Units (Optical or Wired), and any other CPU Bus Units are mounted to a Backplane (CV500-BC101) and connected. |
| Slave Power | Turn on power to the Slaves and check the Slave's status on the 7-segment display (press the display mode switch). The Slave should be in RUN status. |
| CPU Power | Turn on power to the CPU Rack and check that there is no watchdog timer error. (Other alarms and errors are not relevant here.) |
| CVSS System Settings | Start up the CVSS and select "Q: System setup" from the main online menu. Set the destination network addresses (set the network and node addresses to 0 for the local PC). Select "C: Communications Use" and select "Tool bus" (Peripheral device interface). Set the response monitor time to 10 s. Quit System Settings. |
| PC Setup | From the CVSS, select "A: PC setup" from the main online menu. Select "A: PC setup" again and set the operating parameters for the PC. |
| Connecting CVSS | Connect the Peripheral Device directly to the CPU (not to the Slave). Go to the Online Mode by pressing the F1 Key while holding down the Shift Key. The main menu of the Online Mode will be displayed. |
| Transferring PC Setup | Select "A: PC setup" from the main CVSS online menu. Select "T: Transfer PC settings" and transfer the PC Setup from the CVSS to the PC. The settings in the PC will be initialized. |
| Setting the First Word | If not changing the first words for Slave Racks, skip to "Creating the I/O Table." To change the first word settings, select "A: PC Setup." Select "N: Group 3, RT 1st addr." Select the Master and set the address of the first word for each Slave Rack. Press the Shift and Esc Keys. |
| Creating I/O Tables | Select "I: Edit I/O Table" from the main online menu. Clear the settings for unused CPU Bus Units (CPU SIOU). Display the I/O table and check the word allocations After creating the I/O table, move the cursor to CPU Bus Unit area by pressing the Right Key while holding down the Shift Key. Select the Master with the cursor, and select G3. (The Master's I/O table will be displayed on the CVSS.) If you press the Up Key, the next Master I/O table will be displayed. If an I/O table cannot be completed, refer to <i>8-7 I/O Table</i> . |
| Master Indicators | Check to see that the RUN, SD, CD, and T/R indicators on the Master are lit, and that the ERC, ERH, and ERT indicators are not lit. Note If the status of the indicators is not as written above, then refer to <i>Section 8 Troubleshooting</i> and clear the error. |

Slave Indicators

Check to see that the RUN, SD, CD, and T/R indicators on the Slave are lit and that the ERH and ERT indicators are not lit. Check the Slave's first word display.

Note If the status of the indicators is not as written above, then refer to *Section 8 Troubleshooting* and clear the error.

Setting the Master

The default settings for the Master are as follows:

| | |
|--|------------|
| Error check (Continuous/Cumulative): | Continuous |
| Transmission error count (1 to 255): | 10 |
| Communications error processing (Stop/Don't stop): | Don't stop |
| Communications cycle time (5 ms to 32 ms): | 5 ms |

To change these settings, do the following for each Master:

Connect the CVSS, and go online.
 Select "X: Communications Unit setup."
 Select "S: Comm Unit settings."
 Select "B: SYSMAC BUS/2."

Make the changes in the settings described above.

The changes will go into effect the next time the System is started up.

7-2 User Program for 7-Segment Display

Example 1

In the following system configuration, when timer T1000 goes to #1234, the contents of CIO 0200 are displayed in Mode 3 on the 7-segment display of Slave #0. For details on the display characters of 7-segment display, refer to *Setting Display Characters* on the following page. For details on using IODP(189), refer to the *CV-series PC Operation Manual: Ladder Diagrams*.

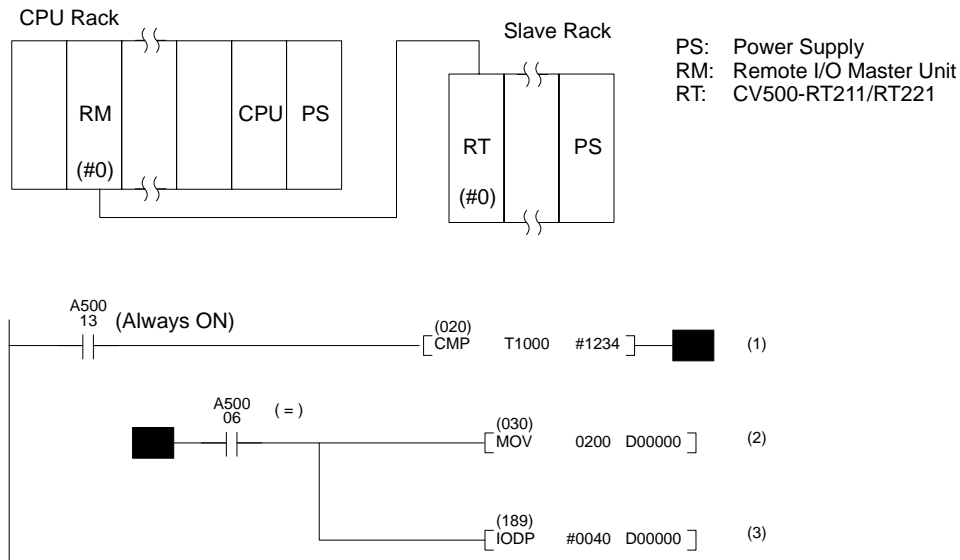

- (1) With each cycle, the timer is checked to see if it has reached #1234.
- (2) If the value of the timer is #1234, the contents of CIO 0200 are transferred to D00000.
- (3) The contents of D00000 are displayed at Slave #0.

Example 2

In the following system configuration, “Err1” will be displayed in Mode 3 on the 7-segment display of Slave #1 when bit 003015 turns ON. For details on the display characters of 7-segment display, refer to *Setting Display Characters*, below. For details on using IODP(189), refer to the CV-series PC Operation Manual: Ladder Diagrams.

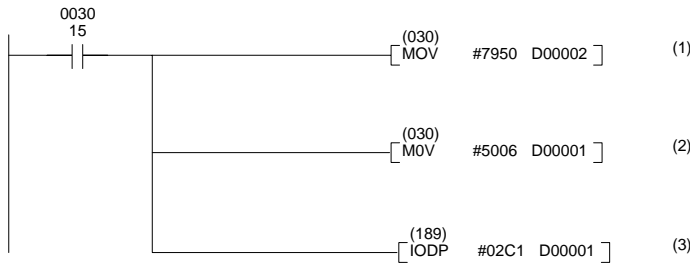
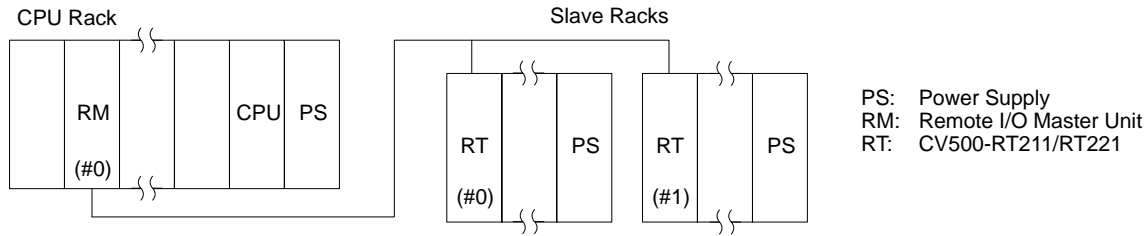

- (1) When 003015 turns ON, the character codes for display characters “Er” are stored in D00002.
#7950 = “Er” (79 = “E”, 50 = “r”)
- (2) The character codes for display characters “r1” are stored in D00001.
#5006 = “r1” (50 = “r”, 06 = “1”)
- (3) The contents of D00001 and D00002 are displayed at Slave #1.

Setting Display Characters

Any or all of the segments of a 7-segment display can be lit to form a display character. A segment is lit by turning ON the corresponding bit. The dot is used for mode display, however, and cannot be manipulated the program. The following is an example of setting display characters.

Bits Corresponding to Segments

Each word is divided into two bytes of 8 bits each so that each word contains two character codes. The hexadecimal character code for display characters can be computed by adding up the bits that must be ON to produce the character, as shown below. The character codes are the same regardless of whether the left byte or right bit is used.

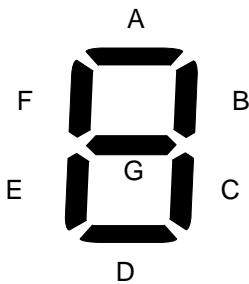

Set bit 7 or 15 to 0.

Example 1

The character codes to display hexadecimal characters are as follows:

| | | | | | | | | | | | | | | | | |
|-----------------|----|----|----|----|----|----|----|----|----|----|----|----|----|----|----|----|
| Characters | 0 | 1 | 2 | 3 | 4 | 5 | 6 | 7 | 8 | 9 | A | B | C | D | E | F |
| Display | 0 | 1 | 2 | 3 | 4 | 5 | 6 | 7 | 8 | 9 | a | b | c | d | e | f |
| Character codes | 3F | 06 | 5B | 4F | 66 | 6D | 7D | 27 | 7F | 6F | 77 | 7C | 39 | 5E | 79 | 71 |

Example 2

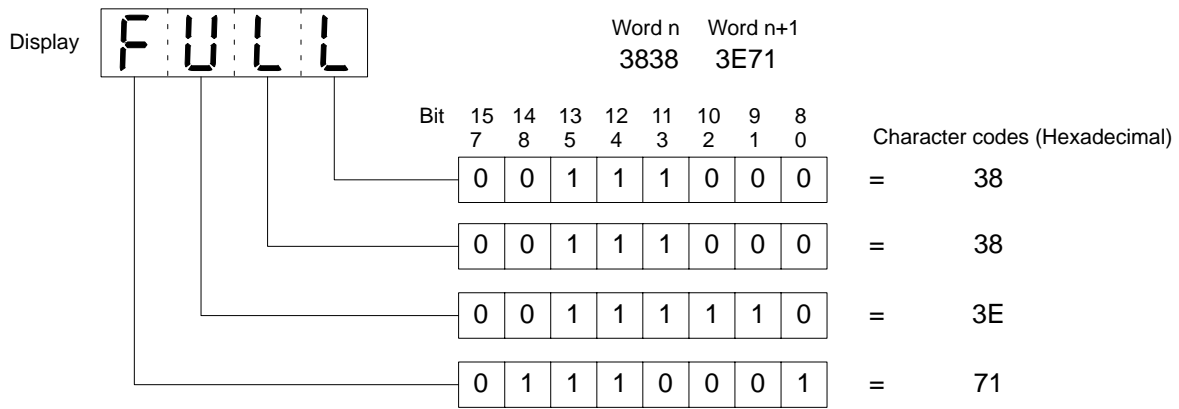

7-3 User Program for Stopping Slave Communications

In the following system configuration, communications are stopped for all of the Slaves in process A if an applications error occurs in any one of them.

The first ANDW(130) detects applications errors and the second ANDW(130) sets the Slave unit numbers into the Slave Communications Start/Restart Word for group-3 Slaves. Bit 150010 is the Slave Communications Stop/Restart Bit for Master #0 and is turned ON to stop communications.

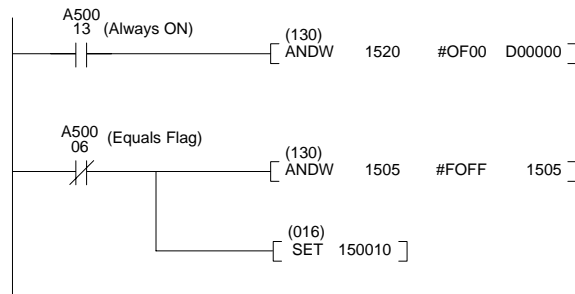
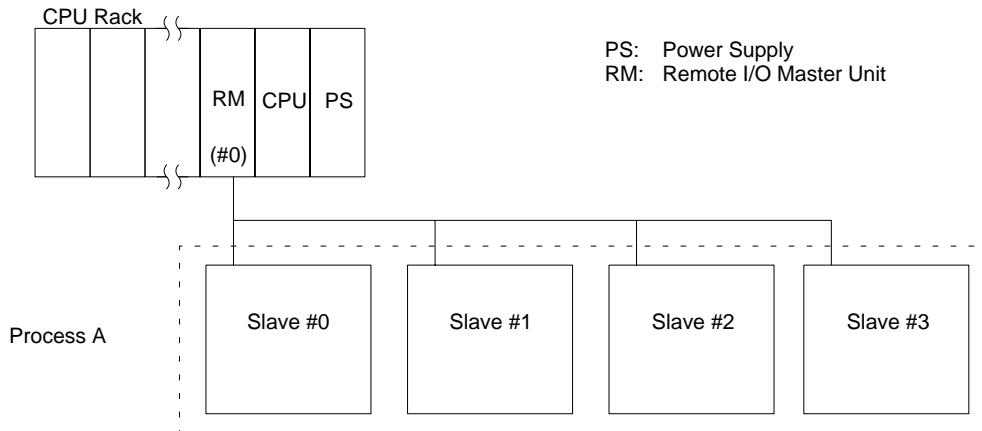

7-4 User Program for Stopping Master Communications

In the following system configuration, communications are stopped for Master #0 and Master #5 if an error (i.e., a system configuration error, I/O setting error, an I/O verification error, or a transmission path error) occurs at any of the Slaves in either process A or process B.

The first ANDW(130) detects errors in the Remote Status word for Master #0 and then SET(016) turns ON the Master Communications Stop/Restart Bits for both Master #0 and Master #1 to stop communications. The second section of the program repeats this operation for errors recorded in the Remote Status word for Master #1.

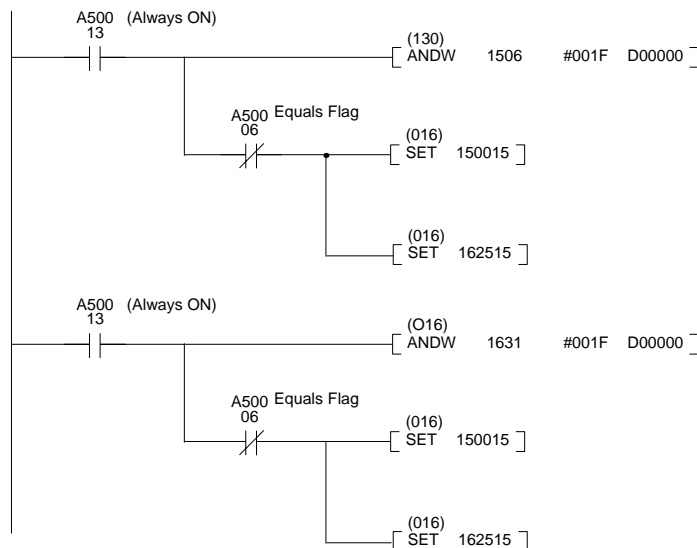
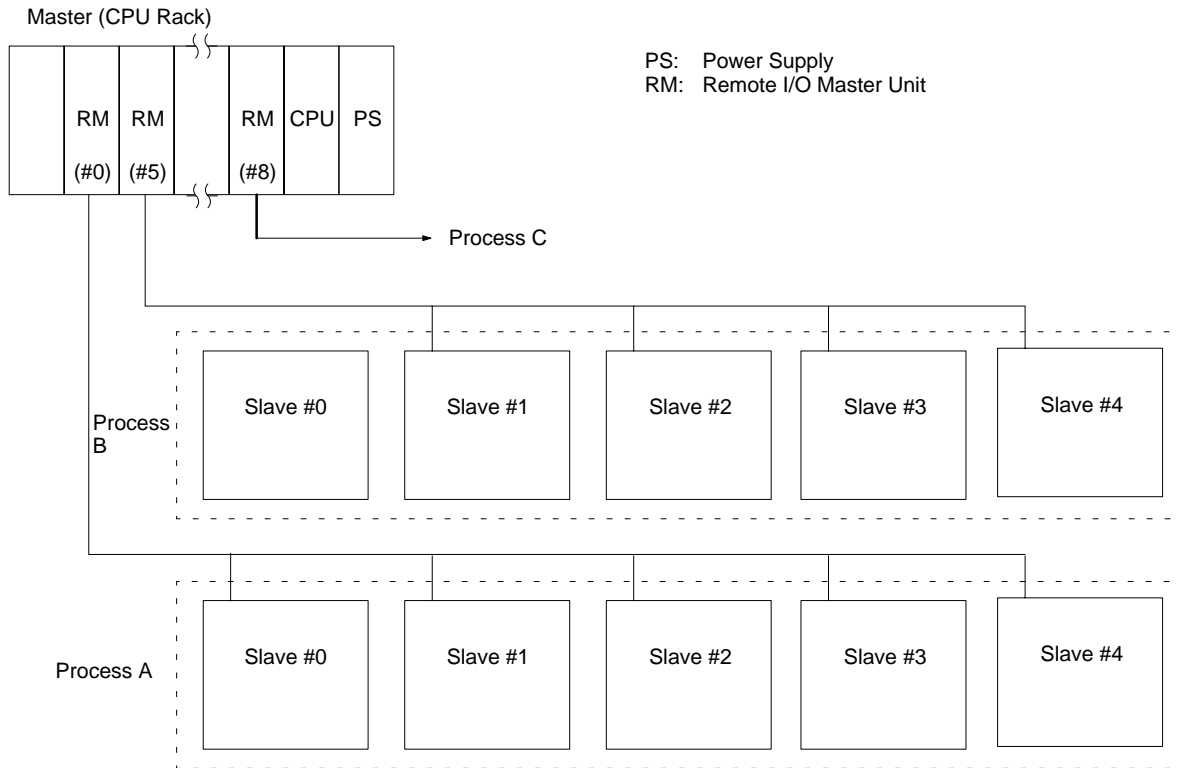

SECTION 8

Troubleshooting

This section describes procedures for locating and correcting errors when the Remote I/O System does not operate properly.

| | | |
|-------|---|-----|
| 8-1 | Troubleshooting Flowcharts | 82 |
| 8-2 | Troubleshooting with Indicators | 83 |
| 8-2-1 | Master Indicators | 83 |
| 8-2-2 | Slave Indicators | 86 |
| 8-2-3 | Slave 7-Segment Displays | 88 |
| 8-3 | Troubleshooting from the CVSS | 88 |
| 8-3-1 | CVSS Error and Alarm Messages | 89 |
| 8-3-2 | Troubleshooting with SYSMAC BUS/2 Support | 89 |
| 8-3-3 | Auxiliary Area | 92 |
| 8-4 | Correcting Errors | 93 |
| 8-4-1 | Corrective Measures | 94 |
| 8-4-2 | Transmission Path Errors | 94 |
| 8-5 | Transmission Path Backup | 97 |
| 8-5-1 | Line Mode Switching | 97 |
| 8-5-2 | Line Modes | 98 |
| 8-6 | Clearing Communications Errors | 101 |
| 8-6-1 | Restarting | 101 |
| 8-6-2 | Clearing a Communications Stop after an Error | 101 |
| 8-7 | I/O Table | 101 |
| 8-7-1 | SYSMAC BUS/2 Recognition Errors | 101 |
| 8-7-2 | I/O Point Overruns | 102 |
| 8-7-3 | Duplicated Addresses and Unit Numbers | 105 |

8-1 Troubleshooting Flowcharts

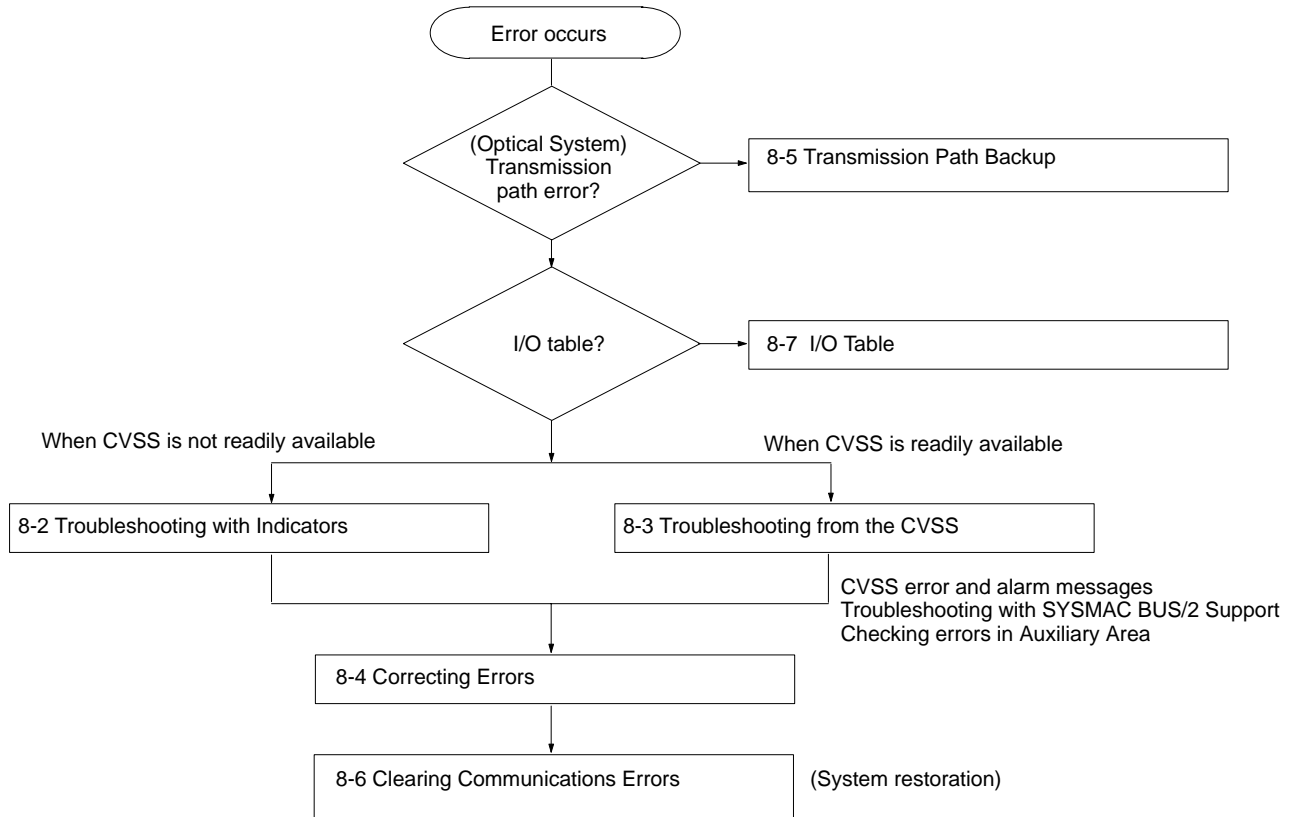

8-2 Troubleshooting with Indicators

If a CVSS is not readily available, you can still check the cause of an error by looking at the indicators on the Masters and Slaves.

8-2-1 Master Indicators

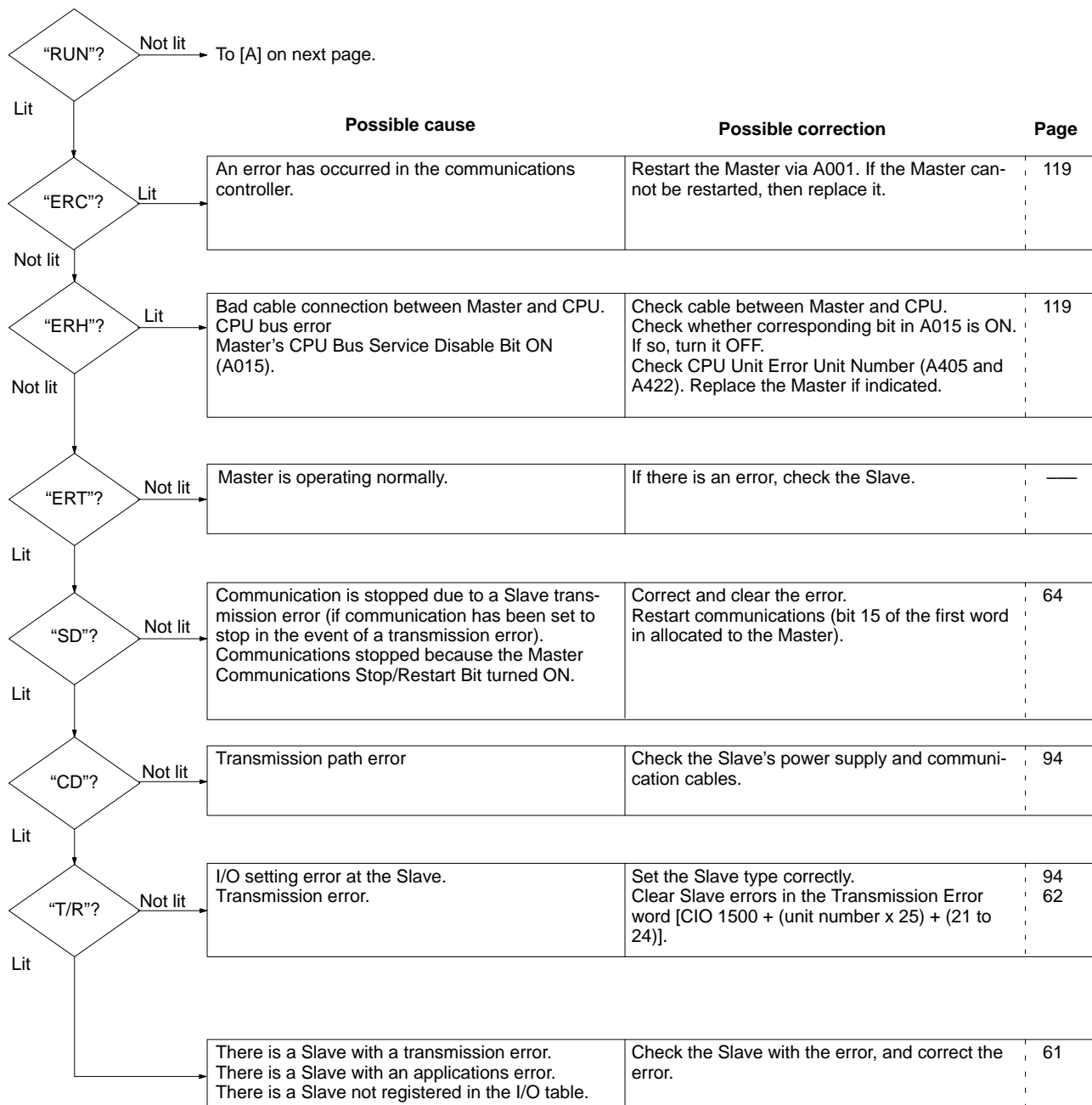

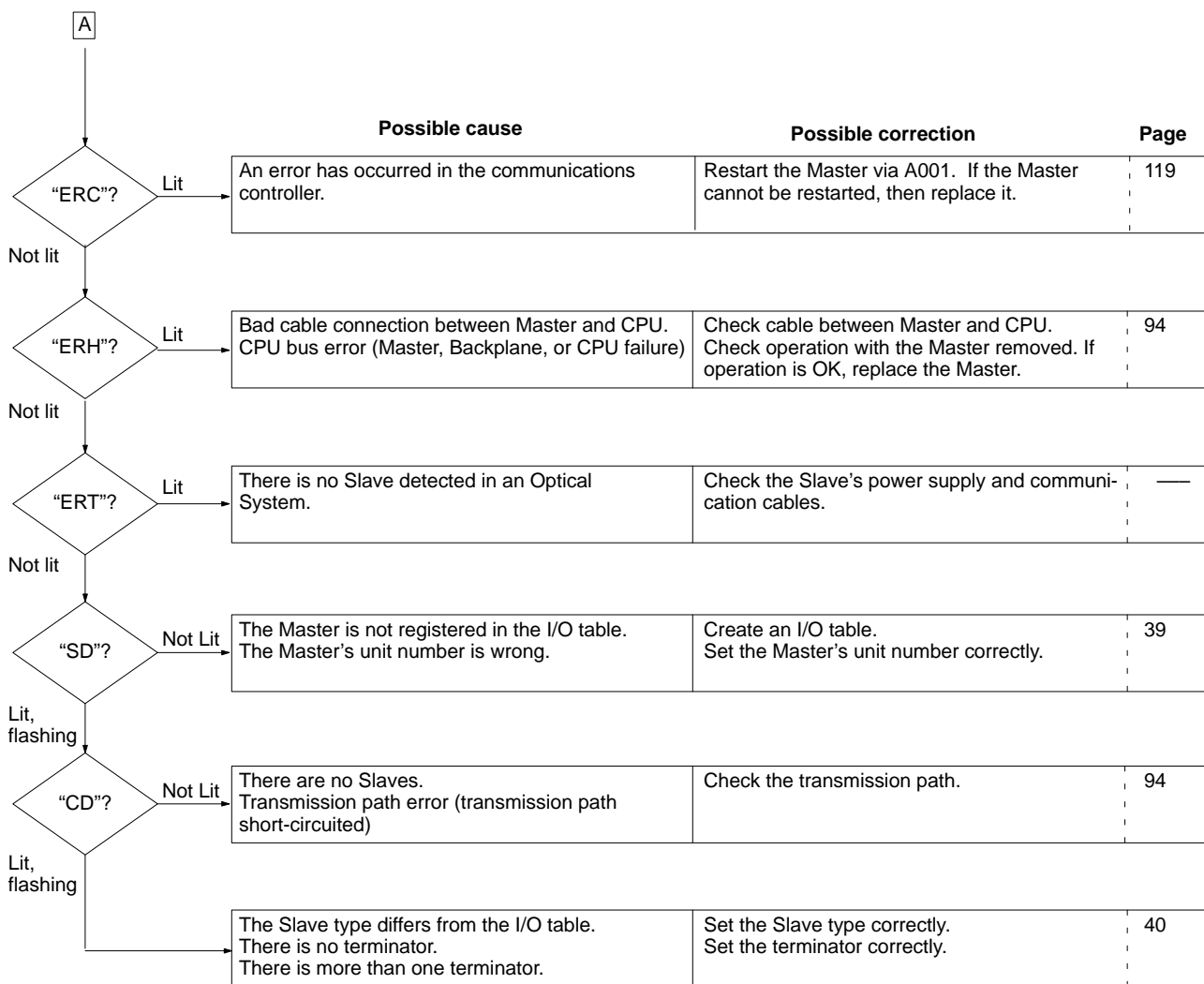

Master Indicators (L: Lit; N: Not lit; F: Flashing)

The ERL indicator flashes in the event of an optical loop error; there may be another error at the same time.

| Indicator | | | | | | | | | Probable cause of error | Possible remedy |
|-----------|-----|-----|-----|-----|--------|----|-----|----|---|--|
| RUN | ERC | ERT | ERH | ERL | S D | CD | T/R | TS | | |
| L | N | N | N | N | L | L | L | N | Normal operation | — |
| N | N | N | N | N | N | N | N | N | Wrong unit number set for the Master. Master not registered in I/O table. | Set the unit number correctly. Create the I/O table. |
| N, L | L | N | N | N | N | N | N | N | Communications controller error (failure at Master). | Restart the Master. If that does not correct the problem, replace the Master. |
| N, L | N | N | L | N | N | N | N | N | CPU bus error Bad cable connection between Master and CPU. | Check the cable connection between the Master and the CPU. If that does not correct the problem, replace the Master. |
| N | N | N | N | N | L | L | N | N | Slave type disagrees with I/O table. | Correct the I/O setting error. |

| Indicator | | | | | | | | | Probable cause of error | Possible remedy |
|-----------|-----|-----|-----|-----|---------|---------|-----|----|---|--|
| RUN | ERC | ERT | ERH | ERL | S D | CD | T/R | TS | | |
| N | N | N | N | N | L, F | N | N | N | There are no Slaves detected. Transmission path error (transmission path short-circuited) | Check the transmission path. |
| N | N | N | N | N | L | L, F | N | N | No terminator. More than one terminator. | Set the terminator correctly. |
| L | N | L | N | N | L | L | L | N | Transmission error has occurred, but operation continues. | Check whether there is a Slave with a power failure. Check whether there is a Slave not connected when one is registered in the I/O table. |
| L | N | L | N | N | L | L | N | N | Transmission error | Correct the Slave at which the error occurred, based on the Transmission Error word [CIO 1500 + (25 x unit number) + (21 to 24)]. |
| L | N | N | N | N | L | L | L | L | Test in progress. | Waiting for test to finish. |
| L | N | N | N | N | L | L | L | F | Test error, or test conducted on non-existent Slave. | Conduct the test again. |
| L | N | N | N | L | L | L | L | N | Loop error (Optical) Positive loop or sub-loop error | For the time being, communications are normal. At a convenient time, check the Slave and the optical fiber cables. |
| L | N | N | L | N | L | L | L | N | Master's CPU Bus Service Disable Bit is ON. | Check word A015 and turn OFF the bit for the Master. |
| L | N | L | N | N | N | N | N | N | Communications are stopped due to a Slave transmission error. Communications stopped because the Master Communications Stop/Restart But turned ON. | Correct and clear the error. Restart communications [bit 15 of word CIO 1500 + (25 x unit number)]. |
| L | N | L | N | N | L | N | N | N | Transmission path error | Check Slave's power supply and cables. |
| L | N | L | N | N | L | L | N | N | I/O setting error at slave. | Set the Slave type correctly. |
| N | N | L | N | N | L | N | N | N | In Optical System, there is no Slave detected. | Check Slave's power supply and cables. |

8-2-2 Slave Indicators

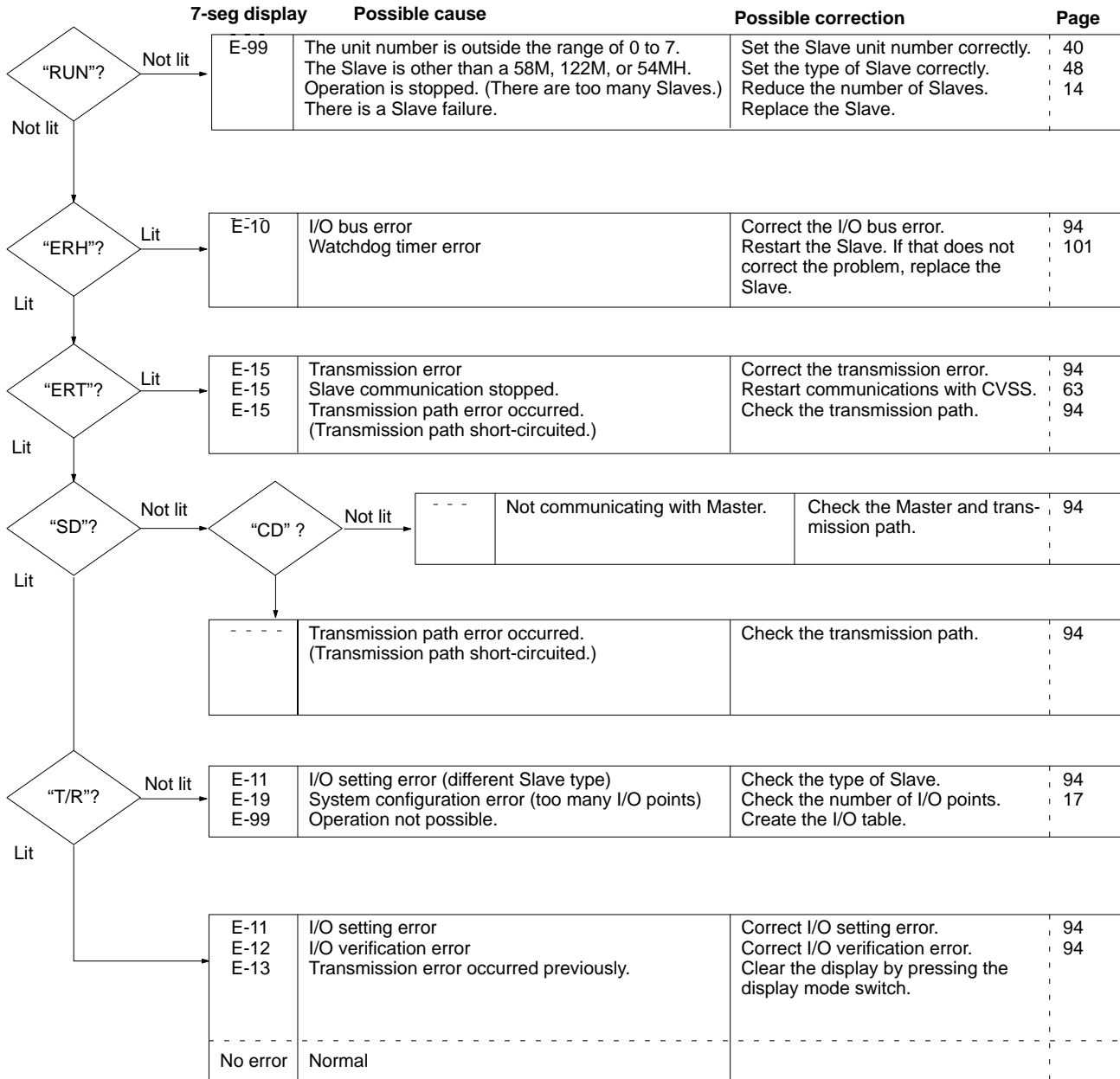

Slave Indicators (L: Lit; N: Not lit; F: Flashing)

If an error occurs, the 7-segment display will flash the message E-**. Error messages will not always automatically disappear even when the error is cleared. If a message remains, you can clear the message by pressing the Slave's display mode switch. Messages are automatically cleared, however, in the following situations:

- When an I/O table is created.
- When the Master is restarted.
- When the Slave is restarted.

After making corrections in a Slave, turn off power to the Slave and then turn it back on.

| Indicators | | | | | | | Probable cause of error | Possible remedy |
|------------|-----|-----|--------|----|-----|--------------------|---|--|
| RUN | ERT | ERH | S D | CD | T/R | 7-segment display | | |
| L | N | N | L | L | L | No error | Normal operation | — |
| N | N | N | N | N | N | --- --- E-99 | Unit error (setting mistake) Slave failure Operation stopped (too many Slaves). | Set the Slave's unit number and type correctly. Replace the Slave. Set the number of Slaves correctly. |
| L | N | N | N | N | N | --- | Master not started. Cable disconnected. | Start up the Master. Check the cables. |
| L | N | N | N | L | N | --- | Transmission path error (transmission path short-circuited) | Check the transmission path. |
| L | N | L | L | L | L | E-10 | I/O bus error | Correct the I/O bus error. |
| L | L | N | N | N | N | E-15 | Transmission error (transmission from Master stopped). | Remove the source of the error, and restart communications from the Master. |
| L | L | N | L | L | N | E-15 | Slave communications stopped. | Restart communications with CVSS. |
| L | L | N | N | L | N | E-15 | Transmission path error (transmission path short-circuited) | Check the transmission path. |
| L | N | N | L | L | L | E-15 | Transmission error occurred previously. | Clear the display by pressing the Master's display mode switch. |
| L | N | N | L | L | L | E-12 | I/O verification error (I/O increase or decrease) | Correct I/O verification error. |
| L | N | N | L | L | N | E-11 | I/O setting error (wrong Slave type set.) | Correct I/O setting error. |
| L | N | N | L | L | L | E-11 | I/O setting error (input and output mixed up.) | Correct I/O setting error. |
| L | N | N | L | L | N | E-99 | Operation not possible (no I/O table). | Create I/O table. |
| L | N | N | L | L | N | E-19 | System configuration error | Mount a Slave type to match number of I/O points. |
| N | N | L | N | N | N | --- | Watchdog timer error | Restart the Slave. If that does not correct the problem, replace the Slave. |
| L | N | N | F | F | N | --- | No terminator. More than one terminator. | Set the terminator correctly. |

8-2-3 Slave 7-Segment Displays

| Message | Meaning | Probable cause of error | Possible remedy |
|---------|--|--|--|
| E-10 | I/O bus error | I/O bus error (Slave, Backplane, or Unit failure) Faulty Unit connections I/O Unit removed during operation. | Replace the defective Unit. Check the Unit's contacts. Turn off the power and remount the Unit that was removed. |
| E-11 | I/O setting error | Slave types disagree with I/O table. I/O setting error occurred at Slave. | Match the Slave setting to the I/O table. Match the I/O configuration to the I/O table. Recreate the I/O table. |
| E-12 | I/O verification error | I/O verification error occurred at Slave. | Recreate the I/O table. Match the I/O configuration to the I/O table. Use as is and ignore alarm. |
| E-15 | Transmission error SD not lit. CD not lit. T/R not lit. | Transmission data reception not normal. (Cable disconnected.) (Power failure at Master.) (Transmission error/cable short-circuit) Communications stopped at Slave itself. Communications stopped at Master. (Error or Communications intentionally stopped at Master.) | Check whether a cable is disconnected. Check whether there is an error at the Master. Check whether there is an error in the transmission path. Check whether communications are stopped at the Slave. Check whether there is a power failure at another Slave. Check whether the SD, CD, and T/R indicators are lit at the Master. |
| | Transmission error SD lit. CD lit. | Transmission error occurred previously. (There was a previous power failure at Master.) (There was a previous transmission path error.) Communications were previously stopped at Slave. Communications were previously stopped at Master. | Transmission is currently being executed normally. Check words A480 to A499 for transmission errors. Refer to <i>Appendix D Auxiliary Area</i> . |
| E-18 | CV Special I/O Unit error | CV Special I/O Unit error at Slave. | For future use. |
| E-19 | System configuration error | Too many words allocated for Slave. | Change the words allocated for the Slave so that the number falls within the allowable range. |
| E-99 | Operation not possible. Operation stopped. | No I/O table entry for Slave Too many Slaves. | Create the I/O table. (When creating the table, turn on the power first at the Slave and then at the Master.) Reduce the number of Slaves. |

8-3 Troubleshooting from the CVSS

If an error occurs in the SYSMAC BUS/2 System, you can connect a CVSS to find the contents of the error. The CVSS can assist in the following functions:

Reading error and alarm contents:

The contents are displayed in the upper left corner. Refer to the following table.

Reading information regarding breakdowns:

Multiple errors and alarms are displayed simultaneously. Refer to the following table.

SYSMAC BUS/2 Support:

Current SYSMAC BUS/2 error conditions are displayed. Refer to the subsequent table.

Monitoring:

The Auxiliary Area can be monitored, providing assistance in discovering the cause of the error. (Refer to *8-3-3 Auxiliary Area*.)

8-3-1 CVSS Error and Alarm Messages

| | | |
|-------------------------------|--------------------------|--|
| CPU bus setting errors | Possible causes | A CPU Bus Unit exists which is not registered in the I/O table. A CPU Bus Unit registered in the I/O table does not exist. The unit number of a CPU Bus Unit disagrees with the I/O table. (These errors may be caused by CPU Bus Units other than Masters.) |
| | Checks | Check the I/O Table with CVSS. Check the error messages from the CVSS. |
| | Possible remedies | Create an I/O table which agrees with the actual configuration. Change the unit numbers to agree with the I/O table. |
| I/O setting error | Possible causes | The Slave type disagrees with the I/O table. An output exists in a slot registered as an input in the I/O table. An input exists in a slot registered as an output in the I/O table. (These errors may be caused by Units outside of SYSMAC BUS/2.) |
| | Checks | Check the I/O Table with CVSS. Check the Slave's 7-segment display. (A Slave with an E-11 message has a setting error.) |
| | Possible remedies | Create an I/O table which agrees with the actual configuration. Change the Slave types or I/O configuration to agree with the I/O table. |
| I/O verification error | Possible causes | A Unit exists which is not registered in the I/O table. A Unit registered in the I/O table does not exist. A Slave unit number registered in the I/O table differs from the actual Slave unit number. (These errors may be caused by configurations outside of SYSMAC BUS/2.) |
| | Checks | Verify the I/O Table with CVSS. Check the Slave's 7-segment display. (A Slave with an E-12 message has a setting error.) |
| | Possible remedies | Create an I/O table which agrees with the actual configuration. Change the Slave unit numbers or I/O configuration to agree with the I/O table. Continue operations, ignoring the alarm. |
| SYSMAC BUS/2 errors | Possible causes | Transmission error has occurred at a Slave. Application error has occurred at a Slave. Unit error has occurred at the Master. I/O setting errors and I/O verification errors can be cleared by creating an I/O table, but the CVSS messages will not be cleared until the error is cleared with the CVSS. |
| | Checks | Check the error with the SYSMAC BUS/2 CPU Bus Unit Area words. Check Slave errors by reading the Slave connection status with the SYSMAC BUS/2 support. Check whether there is an error by reading the cycle time with the SYSMAC BUS/2 support. Check whether there is an error by conducting the communications test with the SYSMAC BUS/2 support. Check whether there is an error by monitoring the Auxiliary Area of the CPU. Refer to <i>Appendix D Auxiliary Area</i> . |
| | Possible remedies | Refer to <i>8-4 Correcting Errors</i> and apply the appropriate remedy. |

8-3-2 Troubleshooting with SYSMAC BUS/2 Support

The SYSMAC BUS/2 Support of the CVSS provides the following functions:

- Display Status
- Test
- Read Cycle Time
- Read Slave Connection Status
- Switch Line Mode

This section will explain how to use Display Status and Read Slave Connection Status to discover the cause of an error.

Display Status

You can display the status of the Master. Display Status shows the status at the point in time that that screen is displayed. (The screen will not change even if

cyclic communications are stopped while the screen is being displayed.) If you want to monitor status changes, use the monitoring features to monitor the status bits in the CPU Bus Unit Area.

| Item | Contents | | Status bit(s) (N: unit number) |
|---|---|--|------------------------------------|
| Communication cables | Wired | The cables in the SYSMAC BUS/2 System are wire. | 1500 + (25 x N) + 6, bits 12 to 14 |
| | Optical | The cables in the SYSMAC BUS/2 System are optical fiber. | |
| Cyclic | Communicating | Normal communications "Normal communications" means that there at least one Slave communicating normally even though there may be other Slaves with errors. If there is even one Slave communicating normally, then the System is considered to be communicating. | 1500 + (25 x N) + 6, bit 15 |
| | Stopped | Communications Stop Bit is ON. An error occurred while communications were set to stop in the event of an error. There is no Slave communicating normally. There is a transmission error. | |
| Line (Optical only) (Optical line conditions are checked when the System is turned on or an error occurs. One of the modes will be automatically set.) | Normal | Positive loop and sub-loop are both OK. Connector SL1 is used. | 1500 + (25 x N) + 7, bit 11 |
| | Sub-line | SL2 used. | 1500 + (25 x N) + 7, bit 12 |
| | Positive Loop | Positive loop is OK; sub-loop has error. | 1500 + (25 x N) + 7, bit 13 |
| | Sub-loop | Sub-loop is OK; positive loop has error. | 1500 + (25 x N) + 7, bit 14 |
| | Dual line | While both connectors are being used there is an error for both the positive loop and sub-loop. | 1500 + (25 x N) + 7, bit 15 |
| Unit error | Master is malfunctioning. Watchdog timer error occurring for the Master. | | 1500 + (25 x N) + 6, bit 4 |
| Transmission path error | No Slave exists. No terminator exists. (Wired System) More than one terminator exists. (Wired System) Cable disconnected between Master and Slave. Cable short-circuited. (Wired System) | | 1500 + (25 x N) + 6, bit 3 |
| I/O verification error | A Unit exists which is not registered in the I/O table. A Unit registered in the I/O table does not exist. A Slave unit number registered in the I/O table differs from the actual unit number. There is a Slave (G1 or G2) registered in the I/O table and a Slave with a different number of I/O points. The actual number of I/O points differs from the number registered in the I/O table. | | 1500 + (25 x N) + 6, bit 2 |
| I/O setting error | The Slave type disagrees with that in the I/O table. An output is registered as an input in the I/O table. An input is registered as an output in the I/O table. | | 1500 + (25 x N) + 6, bit 1 |
| System configuration error | There are too many I/O points for a Slave. | | 1500 + (25 x N) + 6, bit 0 |
| Terminator not confirmed. (Wired Systems only) | The Master cannot communicate with the terminator. | | 1500 + (25 x N) + 7, bits 14, 15 |

| Item | Contents | Status bit(s) (N: unit number) |
|--|--|----------------------------------|
| Multiple terminators set. (Wired Systems only) | More than one Slave has been set as the terminator. | 1500 + (25 x N) + 7, bits 14, 15 |
| Sub-loop error (Optical Systems only) | Loop configuration is not set up. Sub-loop is disconnected. | 1500 + (25 x N) + 6, bit 6 |
| Positive loop error | Loop configuration is not set up. Positive loop is disconnected. | 1500 + (25 x N) + 6, bit 7 |

CIO 1500 + (25 x unit number) +6

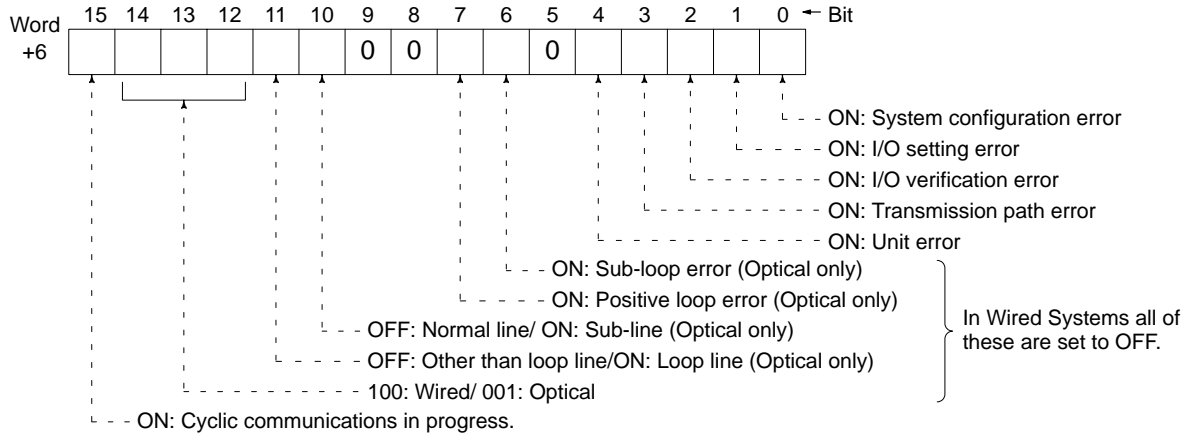

CIO 1500 + (25 x unit number) +7

Wired Systems

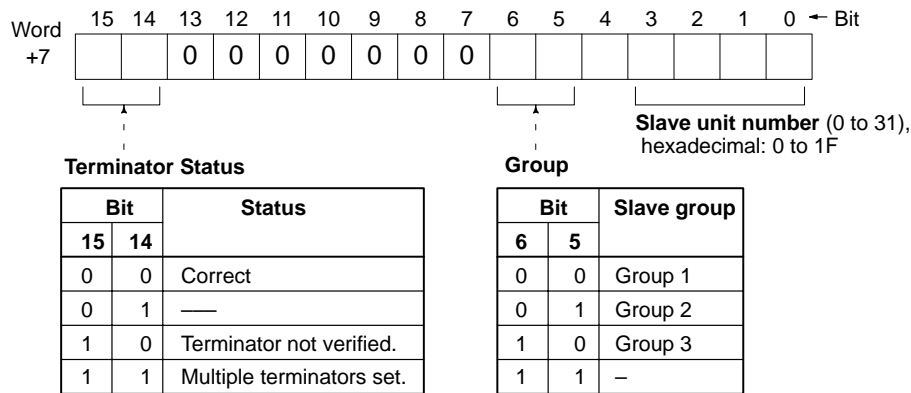

Optical Systems

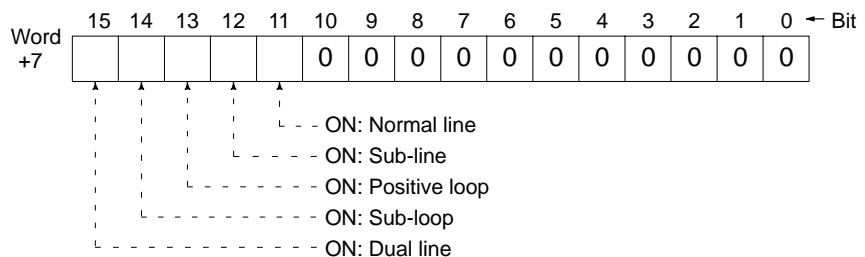

Reading Slave Status

There are four types of Slave status: Active, RUN/Maintenance, Application Error, and Transmission Error. Four words are allocated to each Master from the CPU Bus Area. The addresses of these words are as follows:

Slave active: CIO 1500 + (25 x unit number) + (9 to 12)
 RUN/Maintenance: CIO 1500 + (25 x unit number) + (13 to 16)
 Application Error: CIO 1500 + (25 x unit number) + (17 to 20)
 Transmission Error: CIO 1500 + (25 x unit number) + (21 to 24)

The following table shows how each of these regions corresponds to the respective Slave groups and numbers.

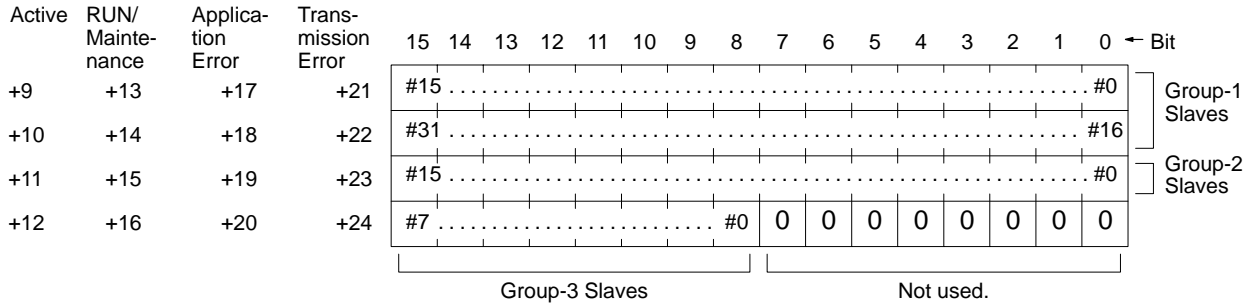

These regions are refreshed while the Master is communicating. While Master communications are stopped, the status prior to the stop is retained.

| Region | Function |
|--------------------|---|
| Active | ON: When the Slave is registered in the I/O table and is active (not stopped). OFF: While communications are stopped for the Slave. While transmission from the Master is stopped, the status prior to the stop is retained. |
| RUN/Maintenance | ON: When operations are in progress during communications. OFF: When Slave is active but no communications are taking place. Once communications are started, the bit remains ON even if a communications error occurs during transmission. The bit is OFF while the Slave is in Maintenance Mode. For Maintenance Mode conditions, refer to the individual operation manuals for the Slaves. (The CV500-RT211 and CV500-RT221 do not have a Maintenance Mode.) |
| Application Error | ON: I/O bus error or watchdog timer error has occurred. OFF: Other than the above. This applies to the CV500-RT211 and CV500-RT221. For other Slaves, refer to their individual operation manuals. |
| Transmission Error | ON: When the set count is reached for transmission errors from the Slave, and communications are stopped due to a cause such as a power failure while the Slave is active. OFF: When the number of transmission errors is fewer than the set count. After an error is generated, the bit turns OFF once normal transmission is executed. (Transmission errors: no response, CRC error) |

Slave Status Regions and Error Contents

| Item | Active | RUN/Maintenance | Application Error | Transmission Error | |
|----------------------------|--------|-----------------|-------------------|--------------------|------------------------------------|
| Normal operation | ON | ON | OFF | OFF | — |
| Maintenance | ON | OFF | OFF | OFF | Communications OFFmal. |
| Not active | OFF | OFF | OFF | OFF | Not registered in I/O table. |
| No Slave | ON | OFF | OFF | ON | Registered in I/O table. |
| Transmission Error | ON | ON | OFF | ON | Error during Slave communications. |
| Application error at Slave | ON | ON | ON | OFF | Communications normal. |

8-3-3 Auxiliary Area

You can monitor the Auxiliary Area by connecting the CVSS and using its Part Screen I/O Monitor or Full Screen I/O Monitor functions.

- 1, 2, 3... 1. Place the CVSS online.

2. Select "M: Monitor" from the Main Menu.
3. The Monitoring Menu will be displayed. Select "B:Monitor Part I/O" or "D:Monitor Full I/O."
4. Specify the bits that you want to monitor, and they will be displayed.

When an error occurs in the SYSMAC BUS/2 System, the bit(s) or word(s) corresponding to the error will provide error information. For details on the Auxiliary Area, refer to *Appendix D Auxiliary Area*.

SYSMAC BUS/2 Master Errors

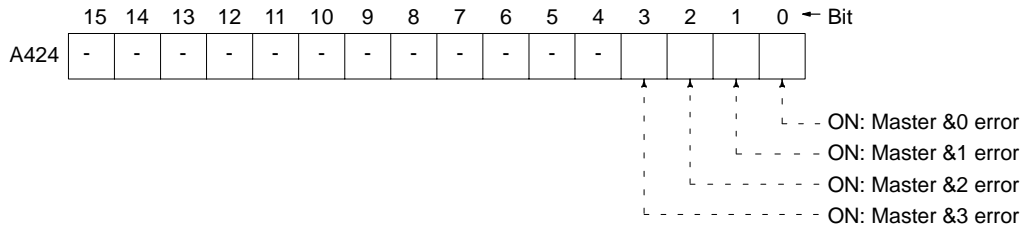

Bits Allocated for SYSMAC BUS/2 Slaves

The bit corresponding to a Slave will turn ON when an error is detected for the Slave.

| | | | | | | | | | | | | | | | | | | | |
|------|------|-----|-------|----|----|----|----|---|---|----|---|---|---|---|---|---|-----|----------------|-----------|
| | | 15 | 14 | 13 | 12 | 11 | 10 | 9 | 8 | 7 | 6 | 5 | 4 | 3 | 2 | 1 | 0 | ← Bit | |
| RM 0 | A480 | #15 | | | | | | | | | | | | | | | #0 | Group-1 Slaves | |
| | A481 | #31 | | | | | | | | | | | | | | | #16 | | |
| | A482 | #15 | | | | | | | | | | | | | | | #0 | Group-2 Slaves | |
| | A483 | #7 | | | | | | | | #0 | 0 | 0 | 0 | 0 | 0 | 0 | 0 | | 0 |
| | A484 | 0 | 0 | 0 | 0 | 0 | 0 | 0 | 0 | 0 | 0 | 0 | 0 | 0 | 0 | 0 | 0 | 0 | Not used. |
| RM 1 | A485 | #15 | | | | | | | | | | | | | | | #0 | Group-1 Slaves | |
| | A486 | #31 | | | | | | | | | | | | | | | #16 | | |
| | A487 | #15 | | | | | | | | | | | | | | | #0 | Group-2 Slaves | |
| | A488 | #7 | | | | | | | | #0 | 0 | 0 | 0 | 0 | 0 | 0 | 0 | | 0 |
| | A489 | 0 | 0 | 0 | 0 | 0 | 0 | 0 | 0 | 0 | 0 | 0 | 0 | 0 | 0 | 0 | 0 | 0 | Not used. |
| RM 2 | A490 | #15 | | | | | | | | | | | | | | | #0 | Group-1 Slaves | |
| | A491 | #31 | | | | | | | | | | | | | | | #16 | | |
| | A492 | #15 | | | | | | | | | | | | | | | #0 | Group-2 Slaves | |
| | A493 | #7 | | | | | | | | #0 | 0 | 0 | 0 | 0 | 0 | 0 | 0 | | 0 |
| | A494 | 0 | 0 | 0 | 0 | 0 | 0 | 0 | 0 | 0 | 0 | 0 | 0 | 0 | 0 | 0 | 0 | 0 | Not used. |
| RM 3 | A495 | #15 | | | | | | | | | | | | | | | #0 | Group-1 Slaves | |
| | A496 | #31 | | | | | | | | | | | | | | | #16 | | |
| | A497 | #15 | | | | | | | | | | | | | | | #0 | Group-2 Slaves | |
| | A498 | #7 | | | | | | | | #0 | 0 | 0 | 0 | 0 | 0 | 0 | 0 | | 0 |
| | A499 | 0 | 0 | 0 | 0 | 0 | 0 | 0 | 0 | 0 | 0 | 0 | 0 | 0 | 0 | 0 | 0 | 0 | Not used. |

8-4 Correcting Errors

Once the cause of the error has been identified, you can apply the appropriate remedy. The following table lists the various types of errors and describes how to correct them.

8-4-1 Corrective Measures

| Error | Possible Remedy |
|---|---|
| I/O bus error (CV500-RT211/RT2 21 only) | Check to be sure that the Units are mounted correctly. Was a Unit mounted or removed during operation? When mounting or removing Units, turn off the power and then restart. |
| I/O setting error | Check whether a group-3 Slave type disagrees with the I/O table. Find the location of the error by using a Peripheral Device to verify the I/O table. Remount the Units according to the I/O table, and power up the System again. If you want to keep the present configuration, then create an I/O table with the Peripheral Device. |
| I/O verification error | Check whether there is a Slave with the power off. Check to be sure that the Units are correctly mounted. Find the location of the error by using a Peripheral Device to verify the I/O table. Remount the Units according to the I/O table, and power up again. If you want to keep the present configuration, then create an I/O table with the Peripheral Device. If a dummy words are registered in order to preserve a word, or if communications are stopped for a Slave, then an I/O verification error will be generated but operation can continue. |
| System configuration error | Inspect the Slave which is indicating that a system configuration error occurred. Has the allowable number of I/O points been exceeded? Check the above, and clear the system configuration error in the Slave. Are there more than 32 Slaves connected to a single Master? Is the sum of group-3 Slaves greater than 8, with 58M Slaves counted as one each and 54MH and 122M Slaves counted as two each? (Refer to 2-2-1 Slaves.) Do Slave unit numbers overlap? After correcting the System configuration, restart the Master. |
| Transmission error | Look for the cause of the transmission error. (Refer to p. 94.) Check whether a transmission path error has occurred. If using a Wired System, check whether the last Slave (and only the last Slave) has been set as the terminator. Check whether the plus and minus terminals are wired correctly, and that the overall cable length is within the specifications. Be sure to connect a ground to the shield. Inspect the cables for damage. Check whether the Slave with which the Master is trying to communicate is disconnected or has the power turned off. (A Slave is not communicating if its SD and CD indicators are not lit.) When the above causes are removed, the error display will be cleared. If communications have been set to stop in the event of an error, then clear the communications stop with the Control Switch word. (Refer to p. 101) |
| Transmission path error | Look for the cause of the transmission error. (Refer to p. 94.) Check whether the cables are connected correctly and that there are no short circuits. If using a Wired System, check whether the last Slave (and only the last Slave) has been set as the terminator. If you do not find the problem after checking the above, the Master may be defective. Replace the Master. Once the problem is removed, the error display will be cleared. If communications have been set to stop in the event of an error, then clear the communications stop with the Control Switch. (Refer to p. 101.) |
| Transmission path interrupted | If the transmission path has been interrupted, it will show as a transmission error. If transmission errors are occurring around the location of the terminator, there may be an interruption in the transmission path. Isolate the location of the errors and replace the cable. (Refer to p. 94.) |
| Unit error | Restart the Master. If errors are occurring frequently, the Master may be defective. Replace the Master. |
| CPU bus error | Check whether the Master is mounted correctly, and then restart the Master. If that does not clear the error, then replace the CPU or the Master. |

8-4-2 Transmission Path Errors

If there is an error during data transmission or reception, or if the display indicates that no terminator has been verified even though the terminator has been set correctly, then there may be an interruption or faulty wiring in the transmission path. Use the following two methods to find the location of the error.

- Change the terminator setting (Wired Systems only)
- Check the CD indicators on the Slaves.

Changing the Terminator Setting

- 1, 2, 3... 1. If you are using a Wired System, then change the terminator setting from the Slave that is currently set as the terminator to the Slave immediately before it, remove the last section of cable, and then turn on the power.
2. With bits 14 and 15 of the Terminator Status word in the CPU, check whether the terminator is correctly set. (Refer to p. 48.)
3. If the terminator is acknowledged, it will be apparent that the error occurred between the Slave currently set as the terminator and the Slave previously set as the terminator (i.e., the path between C and D in the illustration). If the terminator is still not acknowledged, then repeat steps 1 to 3 above. Once the location of the error is determined, replace the defective cable.
4. After the cause of the error has been corrected, again set the last Slave as the terminator and turn the power off and then on again for all the Units.

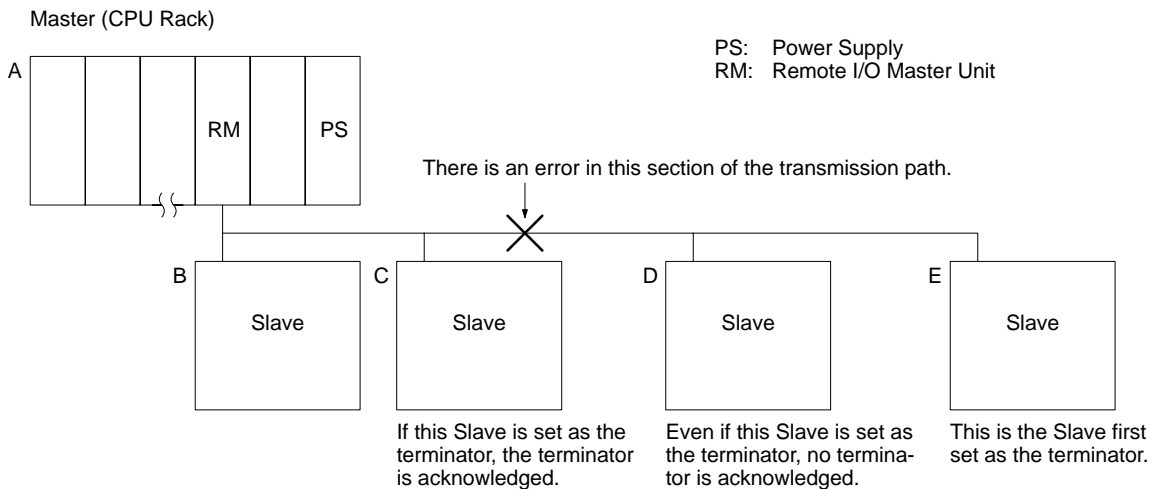

If the problem continues even after the cable has been replaced, then replace the Slave (Slave D or E in the illustration).

- Note**
1. In order for this method to be used, it is essential that the System be correctly configured.
 2. Use these methods before the System begins running, or while the PC is not operating. (Do not change the terminator setting during operation.)

CD Indicators on the Slaves

- 1, 2, 3... 1. Check the Slave CD indicators in order. If the CD indicator is lit, that Slave is receiving data. If the indicator is not lit, the Slave is not receiving data.
2. The error will have occurred between the last Slave with the CD indicator lit and the first Slave with the CD indicator not lit.

3. Replace the cable or correct the wiring, and then use the CD indicators to verify that the problem has been corrected and that data transmission and reception is normal.

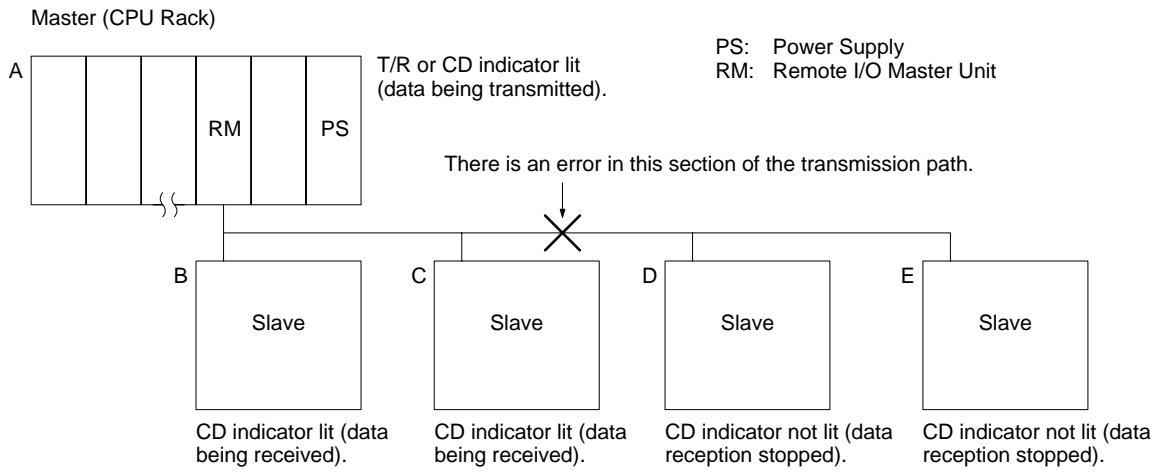

Note This method can be used either before or during operation.

8-5 Transmission Path Backup

Optical Masters check the transmission path when the System is started up and when a transmission error occurs, and they automatically switch the line mode as described below. When there is a loop connection, communications can bypass a transmission path interruption.

8-5-1 Line Mode Switching

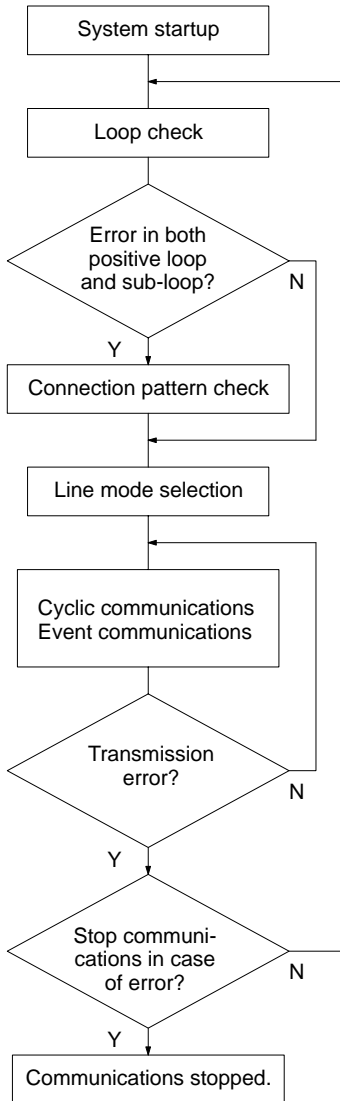

A check is made to see whether the positive loop and sub-loop have been established as transmission paths.

If there is an error in either one of the loops, it is determined that an error has occurred at the loop connection in the transmission path. If there are errors in both loops, it is determined that either there are errors in both or that the Slaves are connected in a daisy chain.

At the Master a check is made to determine whether the upper or lower connector is being used.

Based on the above two checks, the line mode is selected.

| | |
|---|---------------|
| Both loops (OK): | Normal line |
| Positive loop (OK), sub-loop (error): | Positive loop |
| Positive loop (error), sub-loop (OK): | Sub-loop |
| Both loops (errors), both connectors used: | Dual line |
| Both loops (errors), SL1 connector only used: | Normal line |
| Both loops (errors), SL2 connector only used: | Sub-line |

The appropriate bit in the Master's Remote Status and Transmission Path Status words are set according to the line mode that is selected based on the checks that are made.

Note: If the normal line or sub-line can be selected, a transmission path error will not be generated.

Even if an error occurs during the check which is made at the time of startup, the error will be bypassed and communications will be executed in the selected line mode if communications have not been set to stop in the event of an error.

If there are no errors, then cyclic or event communications will be executed.

If a transmission error occurs while the System is being used, and if communications have not been set to stop in the event of an error, then a check will again be made, beginning with the loop check, to determine whether the error can be bypassed. If communications have been set to stop in the event of an error, then communications will stop.

8-5-2 Line Modes

Positive Loop

If the positive loop is OK and the sub-loop has an error, then the positive loop will be used. The Master's ERL indicator will light.

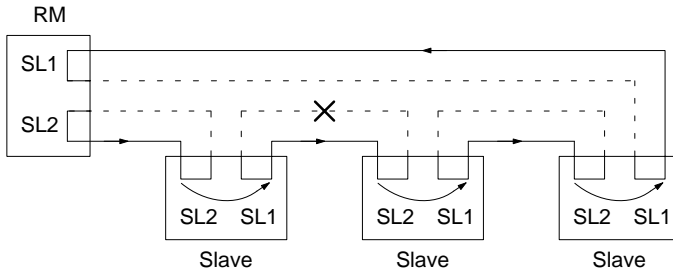

RM: Remote I/O Master Unit
 Slave: Remote I/O Slave Unit
 SL1: Optical connector (upper)
 SL2: Optical connector (lower)
 X : Location of transmission path error
 — : Positive loop (used)
 - - - : Sub-loop (not used)

Remote Status

CIO 1500 + (25 x unit number) + 6

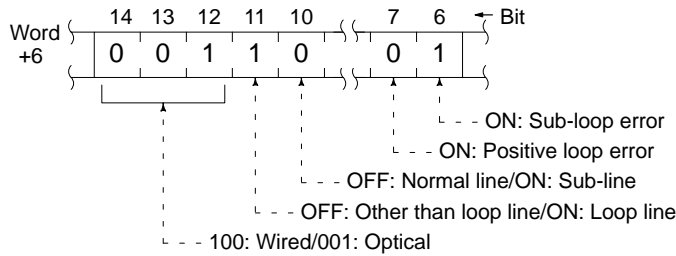

Transmission Path Status

CIO 1500 + (25 x unit number) + 7

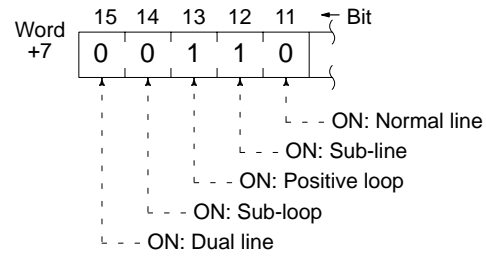

Sub-loop

If the positive loop has an error and the sub-loop is OK, then the sub-loop will be used. The Master's ERL indicator will light.

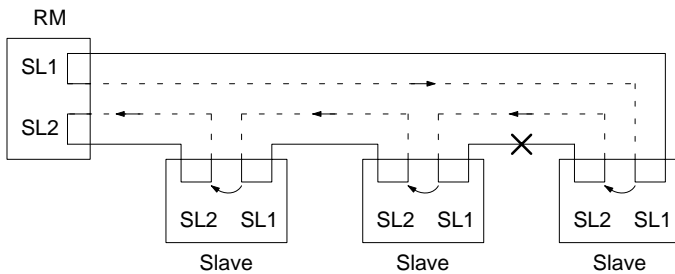

RM: Remote I/O Master Unit
 Slave: Remote I/O Slave Unit
 SL1: Optical connector (upper)
 SL2: Optical connector (lower)
 X : Location of transmission path error
 — : Positive loop (used)
 - - - : Sub-loop (not used)

Remote Status

CIO 1500 + (25 x unit number) + 6

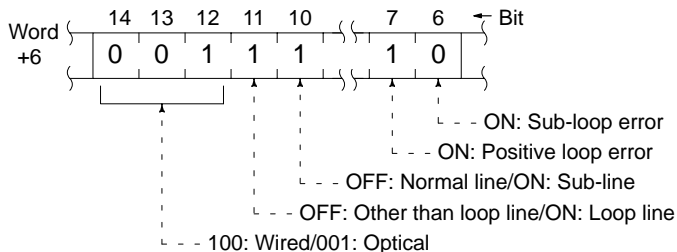

Transmission Path Status

CIO 1500 + (25 x unit number) + 7

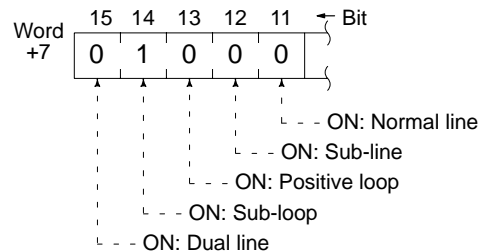

Dual Line (Loop)

If the positive loop and the sub-loop both have errors, and SL1 and SL2 are both connected, then both loops will be used.

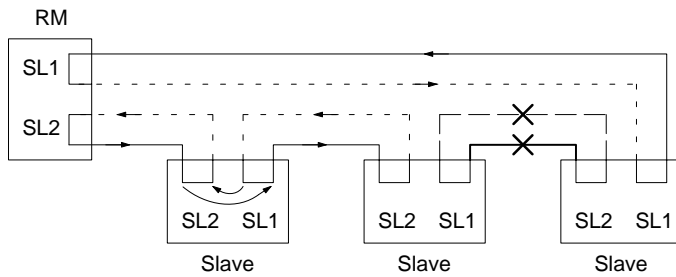

RM: Remote I/O Master Unit
 Slave: Remote I/O Slave Unit
 SL1: Optical connector (upper)
 SL2: Optical connector (lower)
 X : Location of transmission path error
 — : Positive loop (used)
 - - - : Sub-loop (used)
 — : Positive loop (not used)
 - - - : Sub-loop (not used)

Remote Status

CIO 1500 + (25 x unit number) + 6

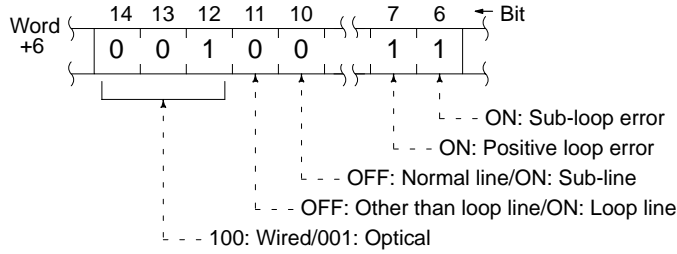

Transmission Path Status

CIO 1500 + (25 x unit number) + 7

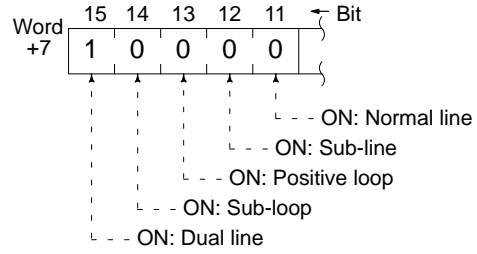

Normal Line (Daisy Chain)

If the Slaves are connected only to SL1, then the normal line will be used.

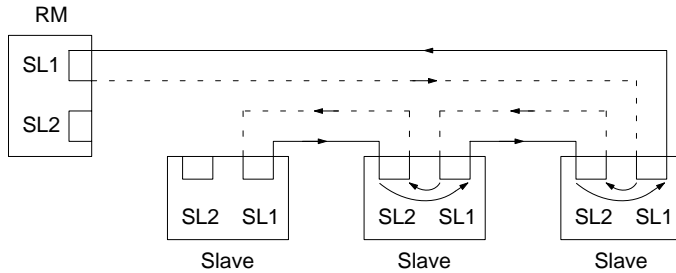

RM: Remote I/O Master Unit
 Slave: Remote I/O Slave Unit
 SL1: Optical connector (upper)
 SL2: Optical connector (lower)
 — : Positive loop (used)
 - - - : Sub-loop (used)

Remote Status

CIO 1500 + (25 x unit number) + 6

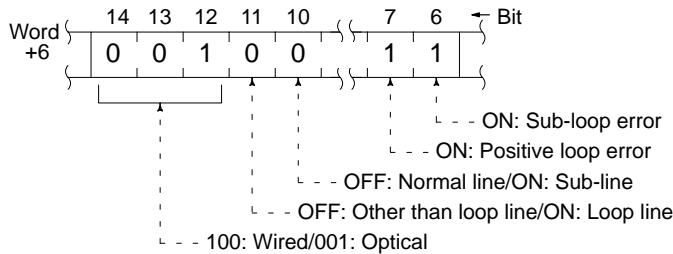

Transmission Path Status

CIO 1500 + (25 x unit number) + 7

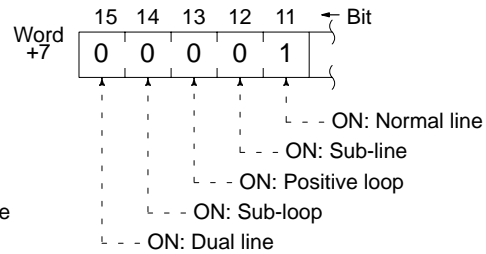

Sub-line (Daisy Chain)

If the Slaves are connected only to SL2, then the sub-line will be used.

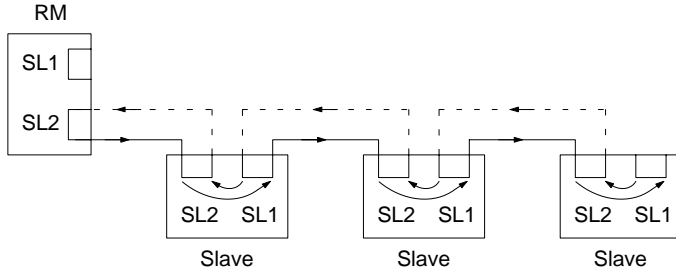

RM: Remote I/O Master Unit
 Slave: Remote I/O Slave Unit
 SL1: Optical connector (upper)
 SL2: Optical connector (lower)
 — : Positive loop (used)
 - - - : Sub-loop (used)

Remote Status

CIO 1500 + (25 x unit number) + 6

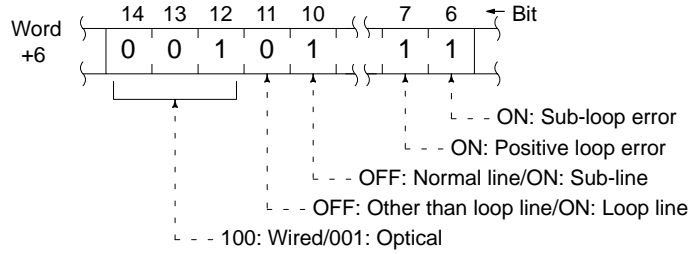

Transmission Path Status

CIO 1500 + (25 x unit number) + 7

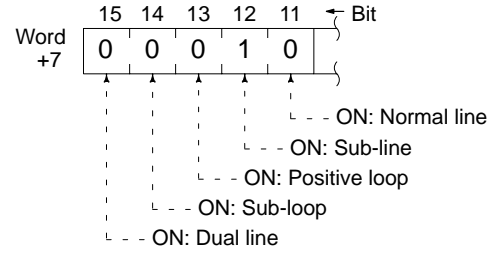

Normal Line (Loop)

If the positive loop and the sub-loop both have errors, the normal line will be used.

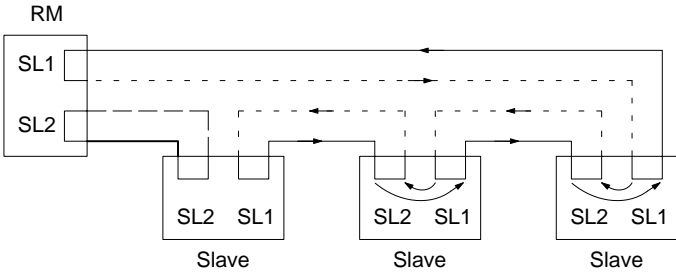

RM: Remote I/O Master Unit
 Slave: Remote I/O Slave Unit
 SL1: Optical connector (upper)
 SL2: Optical connector (lower)
 — : Positive loop (used)
 - - - : Sub-loop (used)
 — : Positive loop (not used)
 - - - : Sub-loop (not used)

Remote Status

CIO 1500 + (25 x unit number) + 6

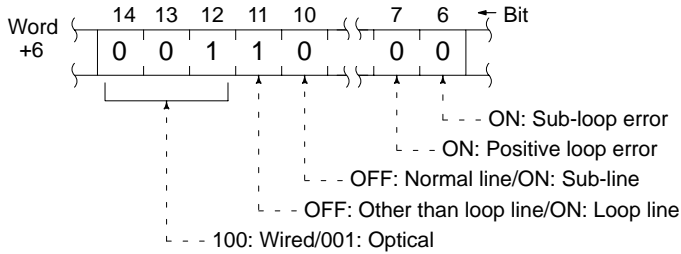

Transmission Path Status

CIO 1500 + (25 x unit number) + 7

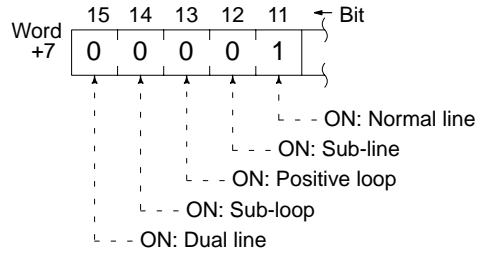

8-6 Clearing Communications Errors

You can use the Control Switch word in the Status region of the Master to restart group-3 Slaves, clear communications stops after errors, and switch Master operations.

The Control Switch word is CIO 1500 + (25 x unit number).

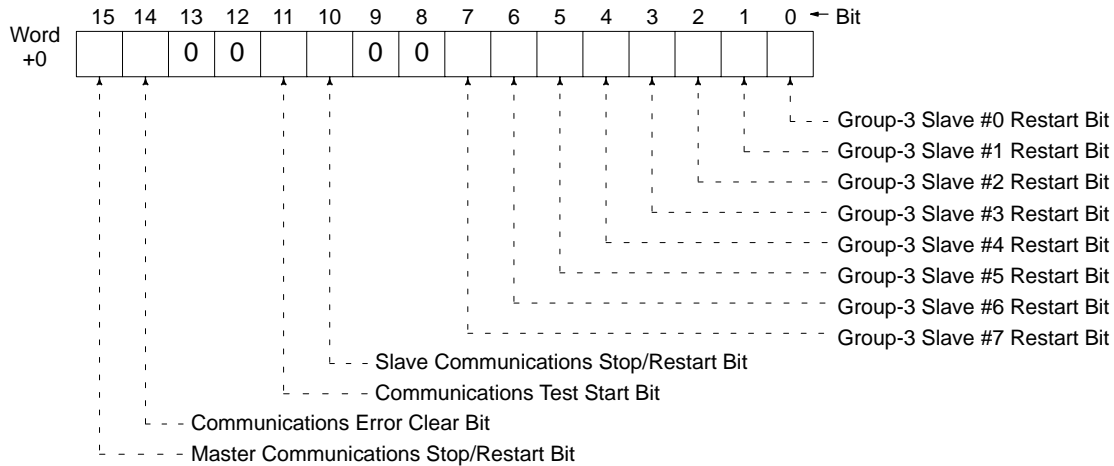

8-6-1 Restarting

- 1, 2, 3...**
1. Turn OFF the bit corresponding to the Slave unit number of the group-3 Slave that you want to restart.
 2. Next turn the bit ON. As the bit status is changed from OFF to ON, the designated group-3 Slave will be restarted.
 3. A similar operation is executed when a group-3 Slave is restarted as when it is first started up. A group-3 Slave cannot be restarted, however, while its communications are stopped.

Note When executing this operation, do not change the other bits.

8-6-2 Clearing a Communications Stop after an Error

In cases where communications have been set in the PC Setup to stop in the event of an error, the following procedure can restart communications.

- 1, 2, 3...**
1. Turn OFF bit 14 in the Control Switch word region.
 2. Turn bit 14 ON. Turning this bit from OFF to ON restarts communications.

Communications can also be restarted by clearing the error with the CVSS.

If an error such as power failure at a Slave persists, communications will immediately stop again and this procedure will not be effective.

8-7 I/O Table

This section will describe how to locate and correct errors related to SYSMAC BUS/2 that may occur when an I/O table is created. The following three kinds of errors may occur in such cases:

- SYSMAC BUS/2 recognition errors
- Too many I/O points
- Address/unit number duplication errors (Refer to 8-7-3 *Duplicated Addresses and Unit Numbers.*)

8-7-1 SYSMAC BUS/2 Recognition Errors

In a Wired System, a SYSMAC BUS/2 recognition error will be generated if an attempt is made to create an I/O table when there are no Slaves. I/O table cannot be created if no Slaves are detected for a Master.

In an Optical System, an I/O table can be generated even if there is only a Master and no Slaves. When that happens, the Master's RUN, ERT, and SD indicators will be lit.

8-7-2 I/O Point Overruns

An I/O point overrun can result from any of the following:

- Too many I/O points for the PC.
- Too many I/O points for SYSMAC BUS/2.
- Too many I/O points for SYSMAC BUS.
- Too many I/O points for CV500-RT211 or CV500-RT221 Slaves.
- Five or more Masters mounted.

You can use the flowcharts on the following pages to locate and correct these errors. The following abbreviations are used in the flowcharts

- Slave:** All Slaves, including all groups.
Group-3 Slave: The CV500-RT211 and CV500-RT221.

Too Many I/O Points

| | | |
|------------------------------------|--|--|
| CV1000/ CV2000/ CVM1-CPU11-E | Does the total number of local I/O points exceed 64 words? | Configure the local System with 64 words or fewer. If there are words available in either SYSMAC BUS/2 or SYSMAC BUS, then the number of local words can be reduced by replacing them with remote words. |
| | Does the total number of I/O points for SYSMAC BUS/2 exceed 128 words? | Configure the System with 128 words or fewer. If there are extra words available in SYSMAC BUS, then the number of SYSMAC BUS/2 words can be reduced by replacing them with SYSMAC BUS words. |
| | Does the total number of I/O points for SYSMAC BUS exceed 64 words? | Configure the System with 64 words or fewer. If there are extra words available in SYSMAC BUS/2, then the number of SYSMAC BUS words can be reduced by replacing them with SYSMAC BUS/2 words. |
| CV500/ CVM1-CPU01-E | Does the total number of local I/O points exceed 32 words? | If the total number of words is within 64, then use a CV1000/CV2000/CVM1-CPU11-E. |
| | Does the total number of I/O points for SYSMAC BUS/2 exceed 64 words? | If the total number of words is within 128, then use a CV1000/CV2000/CVM1-CPU11-E. |
| | Does the total number of I/O points for SYSMAC BUS exceed 32 words? | If the total number of words is within 64, then use a CV1000/CV2000/CVM1-CPU11-E. |

Too Many Masters or Slaves

| | |
|---|---|
| Are there five or more Masters? | Use four or fewer Masters. |
| Are there more than 32 Slaves connected to a single Master? | Divide the Slaves between two Masters, so that there are 32 or fewer connected to each one. |
| Are there more than 16 group-2 Slaves connected to a single Master? | Divide the group-2 Slaves between two Masters, so that there are 16 or fewer connected to each one. |
| Are there too many group-3 Slaves connected to a single Master? (Up to eight can be connected, with 58M Slaves counted as one each and 122M and 54MH Slaves counted as two each.) | Divide the group-3 Slaves between two Masters, so that there are eight or fewer connected to each one, with 58M Slaves counted as one each and 122M and 54MH counted as two each. |

Too Many I/O Points for Group-3 Slaves

| | |
|--|---|
| Are there too many I/O points for 58M Slaves? (Are there more than 29 words for input or 29 words for output?) | Configure the System so that the 58M Slave is using 29 words or fewer for input and 29 words or fewer for output. You can replace the 58M Slave with a 122M Slave, or you can use two 58M Slaves. |
| Are there too many I/O points for 54M Slaves? (Are there more than 27 words for input or 27 words for output?) | Configure the System so that the 54M Slave is using 27 words or fewer for input and 27 or fewer for output. You can use two 54M Slaves. |

Too Many I/O Points for SYSMAC BUS

| | |
|---|--|
| Are there more than 32 words used for a single SYSMAC BUS Master? | Configure the System so that the total number of I/O points for the Master is within 32 words, or divide them between two Masters. |
|---|--|

If there are overlapping Slave unit numbers for Slaves connected to a single Master, those Slaves will be ignored by the Master and will not be entered into the I/O table. If that happens, an I/O point overrun will not occur even if there are too many Slaves connected. In general, an I/O point overrun would occur if, for example, three 122M Slaves were combined with three 58M Slaves. (The total number would be nine, because each 122M Slave is counted as two.)

The I/O table can be written and checked in advance by setting up the CVSS offline and using the Write I/O Table function under Edit I/O Table.

I/O Point Overruns

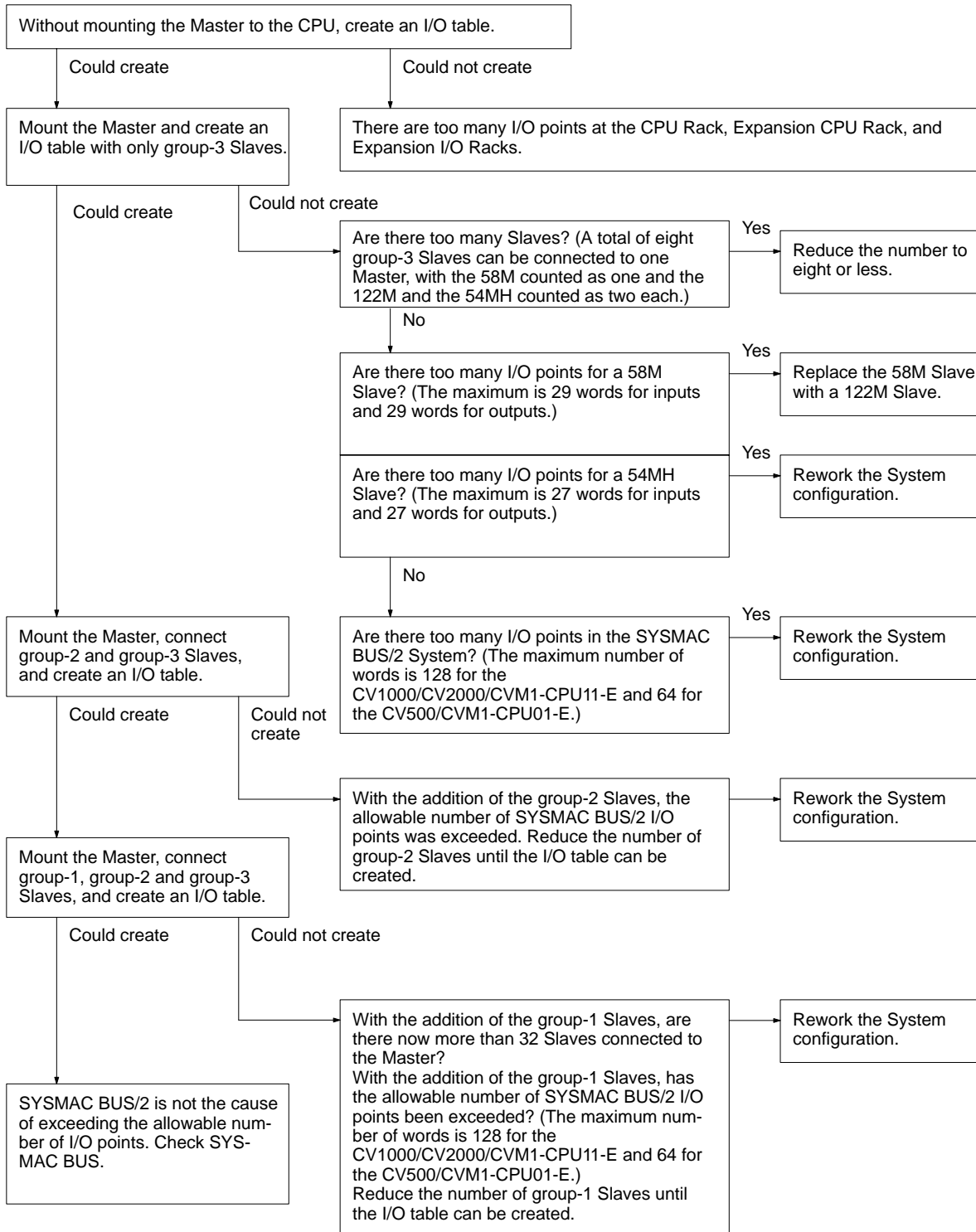

8-7-3 Duplicated Addresses and Unit Numbers

Errors can result from any of the following:

- The same I/O words being allocated more than once on the CPU Rack, Expansion CPU Rack, and Expansion I/O Racks.
- The same I/O words being allocated both to Units on the CPU Rack, Expansion CPU Rack, and Expansion I/O Racks and to SYSMAC BUS/2 Slaves.
- The same I/O words being allocated to two different SYSMAC BUS/2 Slaves.
- The same unit number being assigned to two different CPU Bus Units.

You can use the following flowchart to locate and correct these errors.

Troubleshooting Address/Unit Number Duplication Errors

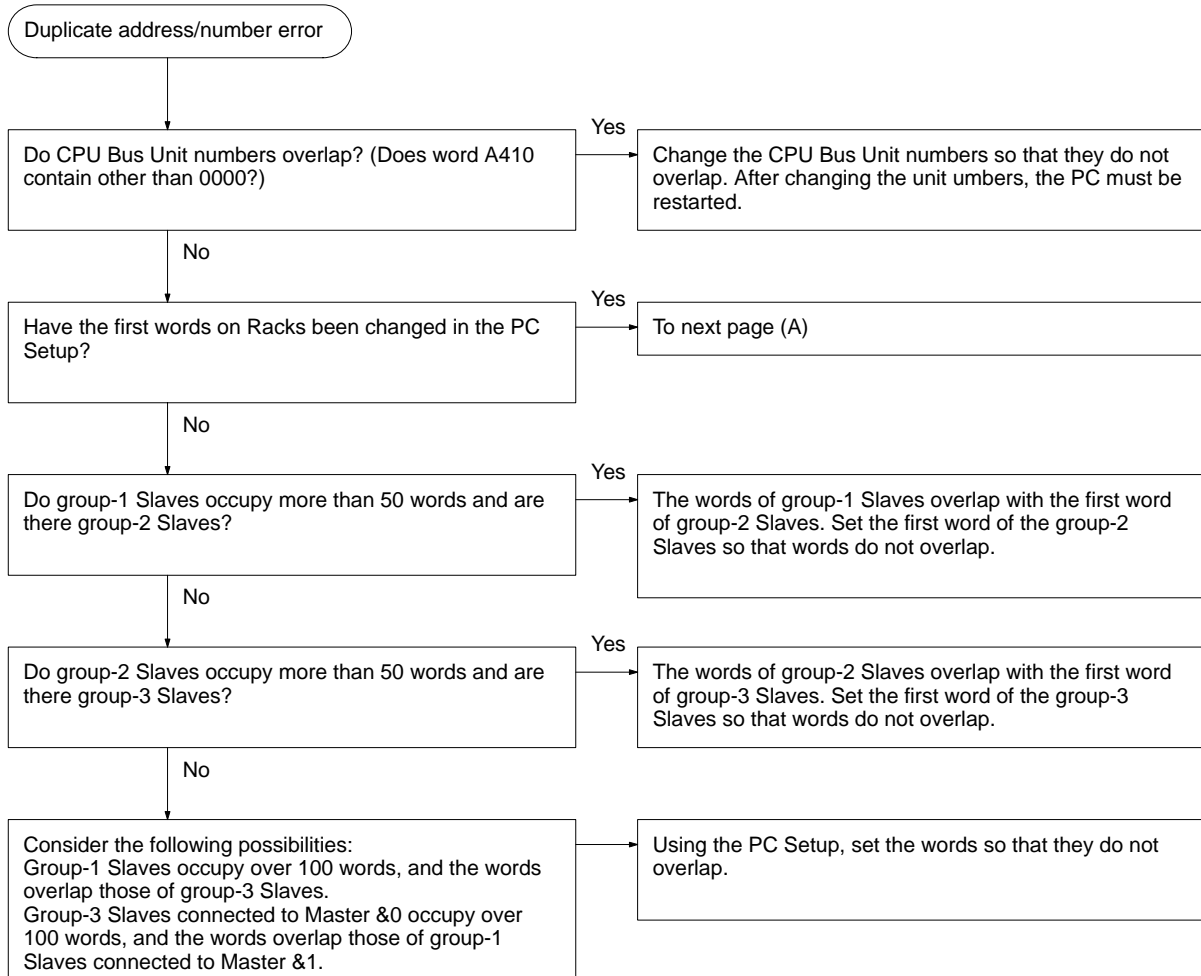

As long as PC Setup is not changed, the word allocations will be as shown below in the table. Therefore, you will need to change the PC Setup if you want to connect to the same Master more than 50 words for group-1 or group-2 Slaves or more than 100 words for group-3 Slaves.

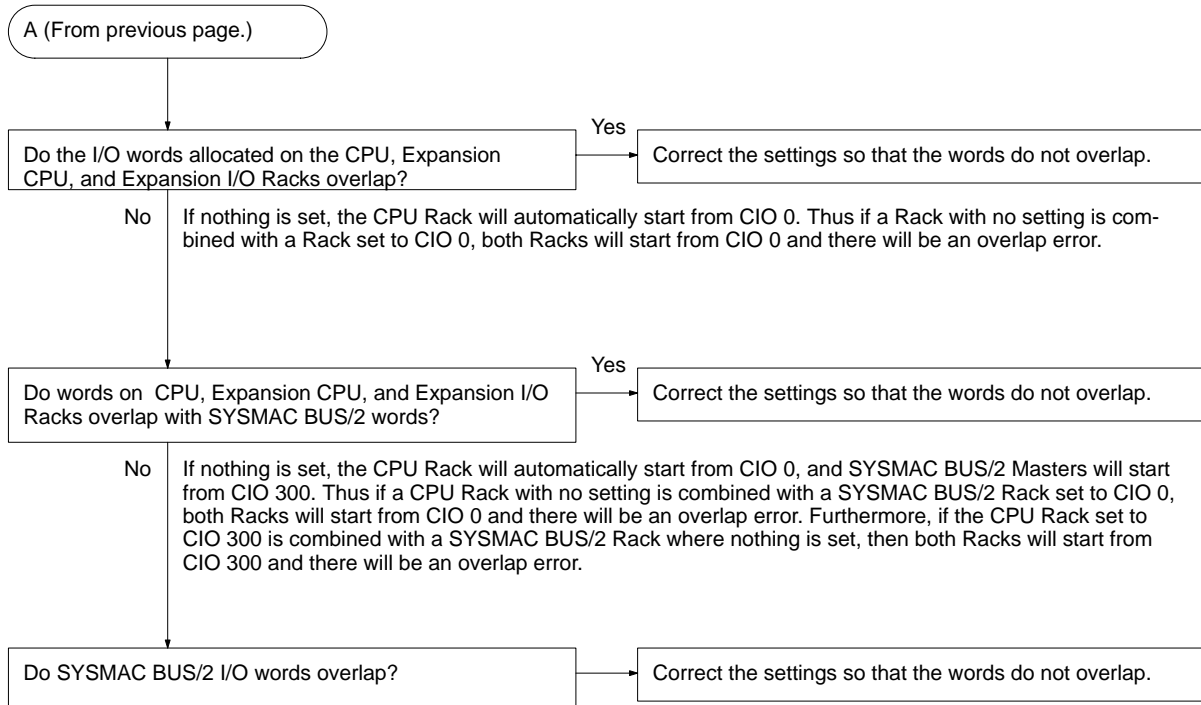

Address duplication errors will result in the following examples:

- The first word of a group-1 Slave is set to CIO 250, and words overlap a group-2 Slave.
- The first word of a group-2 Slave is set to CIO 300, and words overlap a group-3 Slave.
- The first word of a group-3 Slave is set to CIO 100, and words overlap a group-1 Slave.
- There is a group-3 Slave with nothing set (i.e., with a first word of CIO 300), and words overlap a group-3 Slave.

Appendix A

Standard Models

Refer to the *CV-series PC Installation Guide* for a more complete listing of CV-series and compatible C-series products.

Masters and Slaves

| Name | Specifications | Model |
|----------------|----------------|-------------|
| Master | Optical | CV500-RM211 |
| | Wired | CV500-RM221 |
| Slave Group 3) | Optical | CV500-RT211 |
| | Wired | CV500-RT221 |

CPUs

| Name | Model |
|--------|----------------|
| CV500 | CV500-CPU01-E |
| CV1000 | CV1000-CPU01-E |
| CV2000 | CV2000-CPU01-E |
| CVM1 | CVM1-CPU01-E |
| | CVM1-CPU11-E |

Other

| Name | Specifications | Model |
|--------------------------------|-------------------------------|-------------|
| Power Supply Unit | 24 VDC | CV500-PS211 |
| | 100 to 120 VAC/200 to 240 VAC | CV500-PS221 |
| I/O Backplane (for Slave Rack) | 11 slots | CV500-BI112 |

Connecting Cable

Wired Masters and Slaves (CV500-RM221, CV500-RT221)

Use the following shielded twisted-pair cable to connect wired Remote I/O Units (i.e., Master to Slave and Slave to Slave).

| Name | Specifications | Model | |
|--------------------|--------------------|-------|------------|
| Twisted-pair Cable | For Wired Systems. | 10 m | B200-TW101 |
| | | 20 m | B200-TW201 |
| | | 50 m | B200-TW501 |
| | | 100 m | B200-TW102 |
| | | 200 m | B200-TW202 |
| | | 500 m | B200-TW502 |

Optical Masters and Slaves (CV500-RM211, CV500-RT211)

Use the following types of hard plastic optical fiber cord and cable to connect optical Remote I/O Units (i.e., Master to Slave and Slave to Slave).

| Name | Specifications | | Model |
|-------------------------------------|---------------------------------|--------|----------------|
| H-PCF Cord (Optical two-core cord) | Black | 10 m | S3200-HBCB101 |
| | | 50 m | S3200-HBCB501 |
| | | 100 m | S3200-HBCB102 |
| | | 500 m | S3200-HBCB502 |
| | | 1000 m | S3200-HBCB103 |
| H-PCF Cable (Optical two-core cord) | Black (with tension members) | 10 m | S3200-HCCB101 |
| | | 50 m | S3200-HCCB501 |
| | | 100 m | S3200-HCCB102 |
| | | 500 m | S3200-HCCB502 |
| | | 1000 m | S3200-HCCB103 |
| | Orange (with tension members) | 10 m | S3200-HCCO101 |
| | | 50 m | S3200-HCCO501 |
| | | 100 m | S3200-HCCO102 |
| | | 500 m | S3200-HCCO502 |
| | | 1000 m | S3200-HCCO103 |
| | Black (without tension members) | 10 m | S3200-HCCB101N |
| | | 50 m | S3200-HCCB501N |
| | | 100 m | S3200-HCCB102N |
| | | 500 m | S3200-HCCB502N |

Optical cord and cable model numbers are as follows:

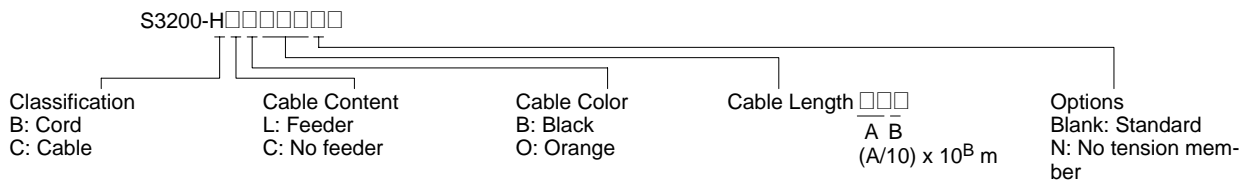

Compatible Special I/O Units

The C-series Special I/O Units shown in the following table can be with the CV500-RT211/RT221. Up to eight Special I/O Units can be mounted to each Slave Rack.

The I/O READ/WRITE instructions (READ(190) and WRIT(191)) can be used for Special I/O Units mounted to Slave Racks only if the following conditions are met.

1. The lot number of the Remote I/O Master Unit and Remote I/O Slave Unit must be the same as or latter than the following.

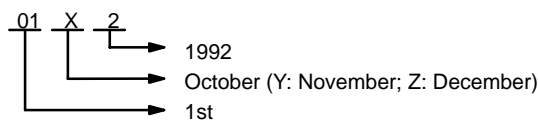

2. The DIP switch on the Remote I/O Slave Unit must be set to "54MH."
3. The Special I/O Unit must be one of the following: AD101, AD501, DA501, CT012, CT021, CT041, ASC04, ASP01, ASP02, IDS01-V2, IDS02-V1, IDS21, IDS22, LDP01-V1, TS501, or TS502. (The NC103, NC221, NC222, CP131, and FZ001 cannot be mounted to Slave Racks.)

| Name | Specifications | Model |
|-------------------------|--|--------------------------|
| Analog Input Unit | 4 to 20 mA, 1 to 5 V | 2 pts 3G2A5-AD001 |
| | 0 to 10 V | 2 pts 3G2A5-AD002 |
| | 0 to 5 V | 2 pts 3G2A5-AD003 |
| | -10 to 10 V | 2 pts 3G2A5-AD004 |
| | -5 to 5 V | 2 pts 3G2A5-AD005 |
| | 4 to 20 mA, 1 to 5 V | 4 pts 3G2A5-AD006 |
| | 0 to 10 V | 4 pts 3G2A5-AD007 |
| | 0 to 10 V, 0 to 20 mA (4-word operation only) | 8 pts C500-AD101 |
| Analog Output Unit | 4 to 20 mA, 1 to 5 V | 2 pts 3G2A5-DA001 |
| | 0 to 10 V | 2 pts 3G2A5-DA002 |
| | 0 to 5 V | 2 pts 3G2A5-DA003 |
| | -10 to 10 V | 2 pts 3G2A5-DA004 |
| | -5 to 5 V | 2 pts 3G2A5-DA005 |
| | 4 to 20 mA, 1 to 5 V, 0 to 10 V | 4 pts C500-DA101 |
| High-speed Counter Unit | 6 BCD digits, 50 Kcps, 1 set value | 1 pt 3G2A5-CT001 |
| | 6 BCD digits, 50 Kcps, 8 set value (Mode 2 only) | 1 pt 3G2A5-CT012 |
| Position Control Unit | 1-axis, for pulse motor | 3G2A5-NC111-EV1 |
| | 2-axis, for pulse motor | C500-NC221-E |
| Cam Positioner Unit | --- | C500-CP131 |
| ASCII Unit | RAM + EEPROM (4-word operation only) | C500-ASC04 |
| Ladder Program I/O Unit | --- | C500-LDP01-V1 |
| ID Sensor Unit | (4-word operation only) | C500-IDS01-V2 |
| | For long distance (CV500-IDA02-E is required) (4-word operation only) | C500-IDS02-V1 |
| | | C500-IDS21 C500-IDS22 |

Appendix B Specifications

General Specifications

Conform to PC specifications.

Performance Characteristics

General

| Item | Specifications | |
|----------------------------|---|---|
| Communications method | 1:N, polling or selective | |
| Code | Manchester | |
| Modulation | Baseband | |
| Transmission method | Time-sharing, multiplexing cyclic and event | |
| Baud rate | 1.5 Mbps | |
| Transmission distance | Wired | Total length: 500 m |
| | Optical | Total length: 10 km Between nodes: 800 m |
| Topology | Wired | Multidrop |
| | Optical | Daisy chain or loop |
| Transmission medium | Wired | Shielded twisted-pair cable |
| | Optical | Hard plastic-clad optical fiber (H-PCF) |
| Number of connecting nodes | 32 max. | |
| Error control method | CRC-CCITT ($X^{16} + X^{12} + X^5 + 1$) | |
| RAS | Transmission path backup, double address check | |
| Transmission capacity | Cyclic: 128 words max. Event: 552 bytes max. | |

Remote I/O Master Units (CV500-RM211/RM221)

| Item | Specifications | |
|------------------------------|------------------------|------------------------|
| | Optical CV500 Masters | Wired CV500 Masters |
| Internal current consumption | 500 mA max. (at 5 VDC) | 500 mA max. (at 5 VDC) |
| Weight | 450 g max. | 450 g max. |

Remote I/O Slave Units (CV500-RT211/RT221)

| Item | Specifications | |
|------------------------------|------------------------|------------------------|
| | Optical CV500 Masters | Wired CV500 Masters |
| Internal current consumption | 600 mA max. (at 5 VDC) | 600 mA max. (at 5 VDC) |
| Weight | 450 g max. | 450 g max. |

Dimensions

The following dimensions are given in millimeters.

Remote I/O Master Units

CV500-RM211

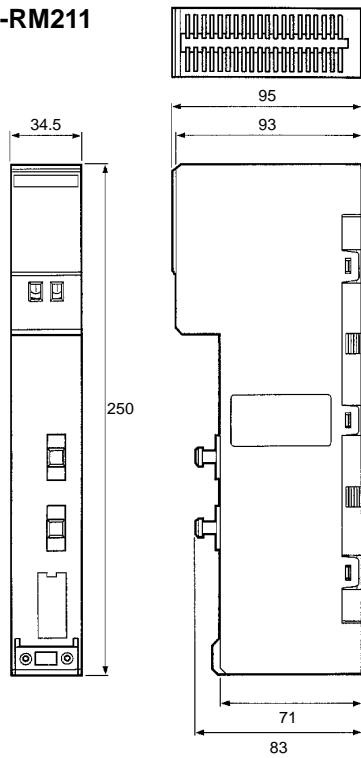

CV500-RM221

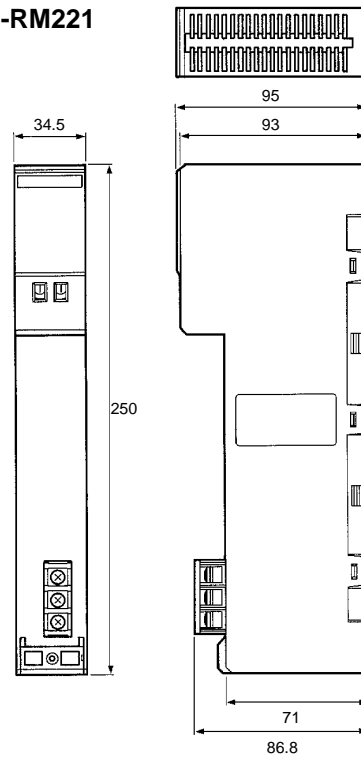

Remote I/O Slave Units

CV500-RT211

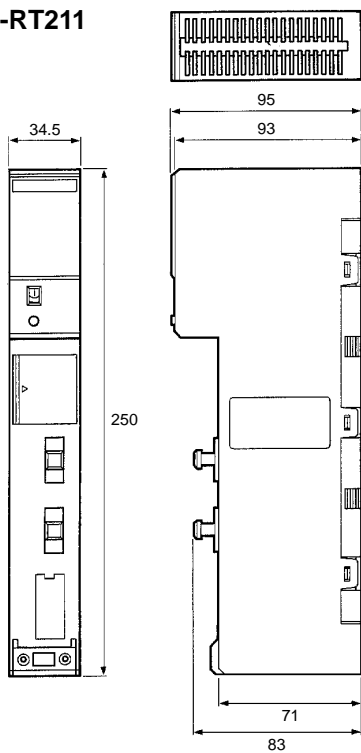

CV500-RT221

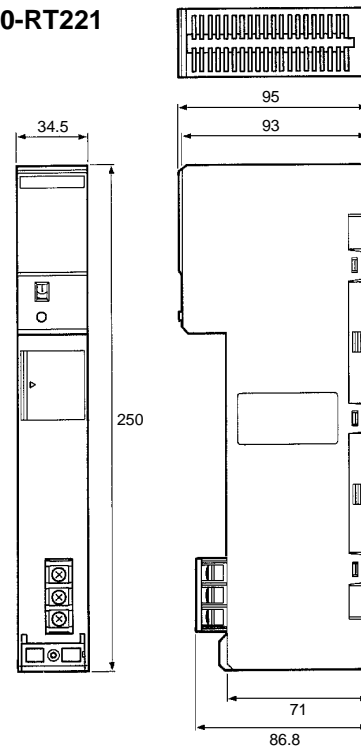

Block Diagrams

Masters

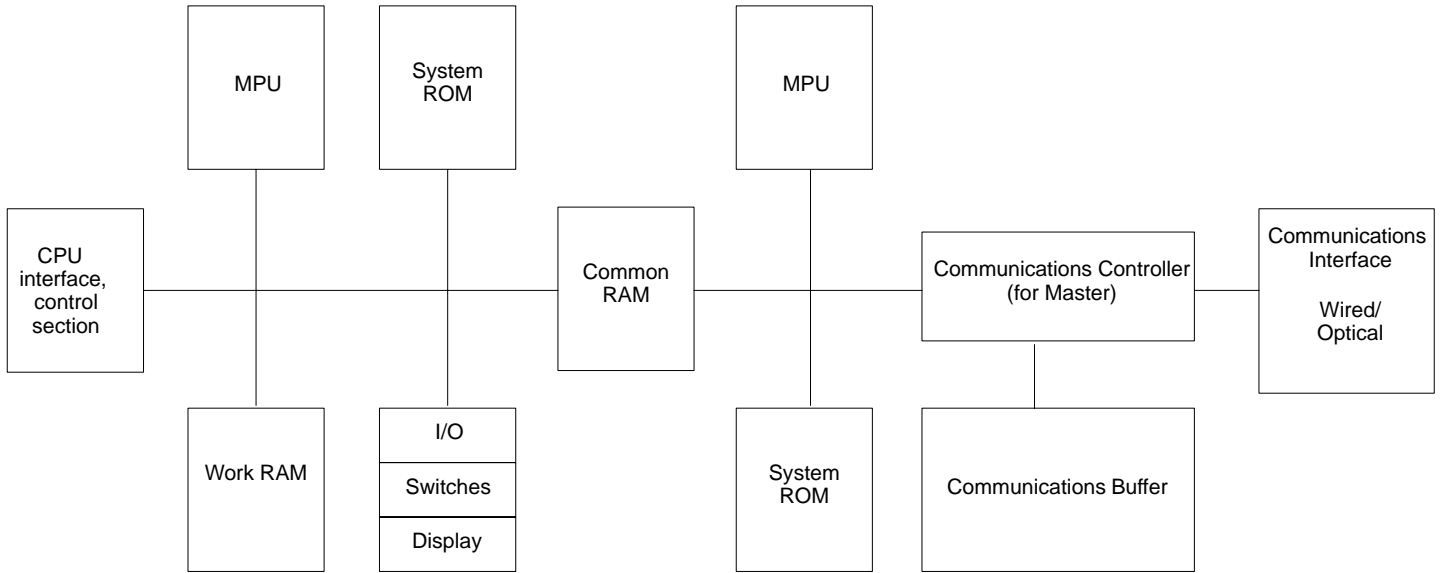

Slaves

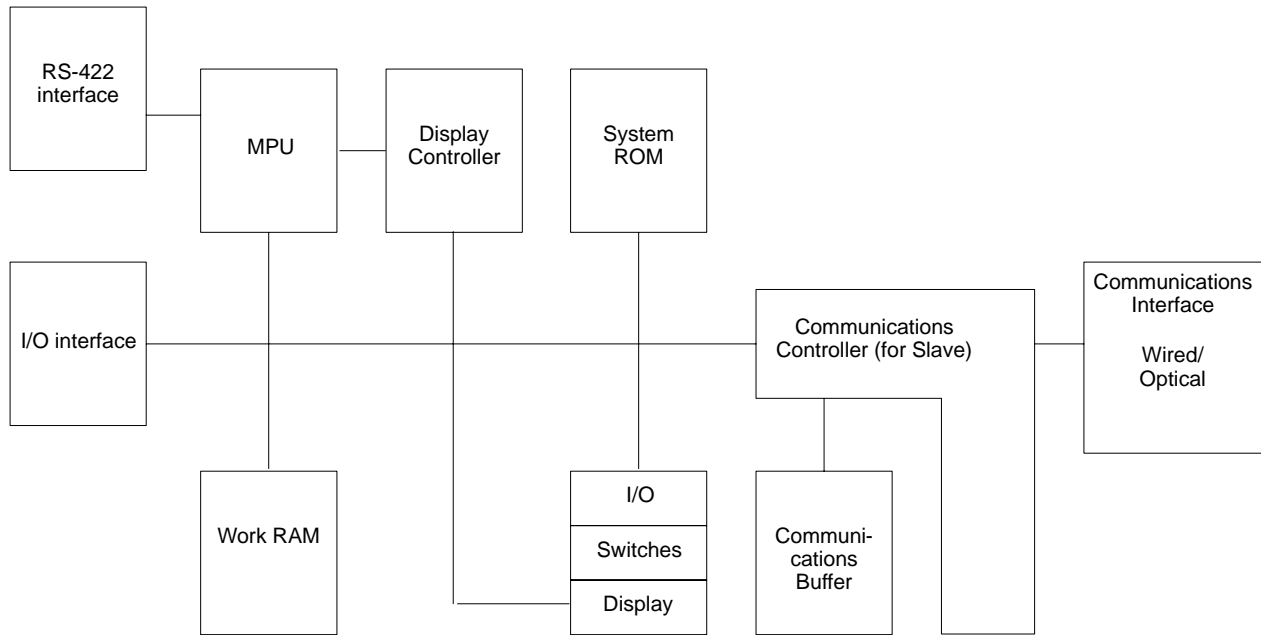

Appendix C

CPU Bus Unit Area

Word Allocations

| First word for each item | Item | Number of Words | Allocations for Master &0 (add 25 x unit number for other Masters) | | |
|------------------------------------|---|-----------------|---|-----------|-------------------------------------|
| CIO 1500 + (25 x unit number) + 0 | Control Switches (p. 62 & 101) | (1 word) | [Word 1500] | | |
| CIO 1500 + (25 x unit number) + 1 | Communications Test (p. 66) | (1 word) | [Word 1501] | | |
| CIO 1500 + (25 x unit number) + 2 | Slave Communications Stop/Restart (p. 63) | (4 words) | [Word 1502] | | |
| CIO 1500 + (25 x unit number) + 6 | | | Remote Status (p. 58) | (1 word) | [Word 1506] |
| CIO 1500 + (25 x unit number) + 7 | | | Wired: Terminator Status Optical: Transmission Path Status (p. 59) | (1 word) | [Word 1507] |
| CIO 1500 + (25 x unit number) + 8 | | | | | Communications Test Results (p. 66) |
| CIO 1500 + (25 x unit number) + 9 | Active Slave Status (p. 60) | (4 words) | [Word 1509] | | |
| CIO 1500 + (25 x unit number) + 13 | | | RUN/Maintenance Status (p. 61) | (4 words) | [Word 1513] |
| CIO 1500 + (25 x unit number) + 17 | | | Application Errors (p. 61) | (4 words) | [Word 1517] |
| CIO 1500 + (25 x unit number) + 21 | Transmission Errors (p. 62) | (4 words) | [Word 1521] | | |
| | | | | | |

Control Switches

CIO 1500 + (25 x Unit Number)

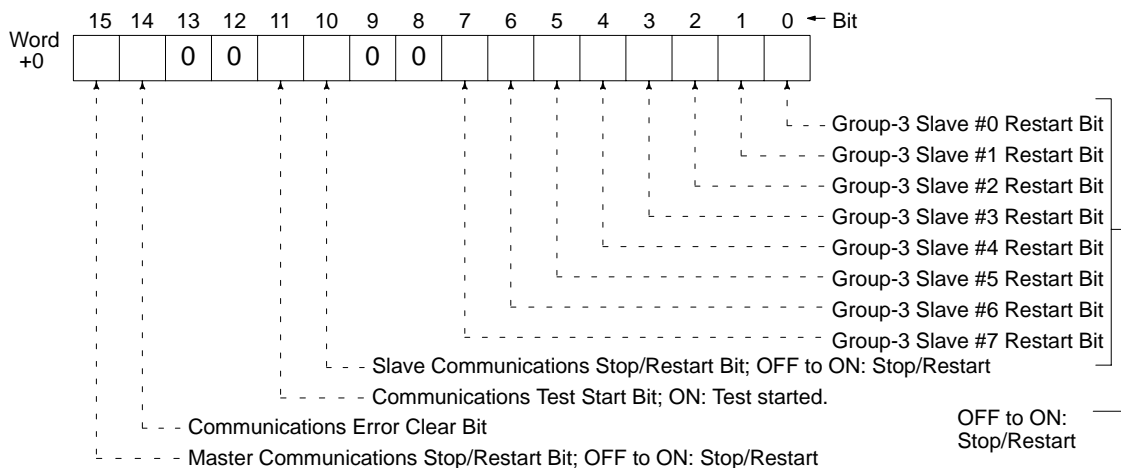

Communications Test Word (p. 66)

CIO 1500 + (25 x Unit Number) + 1

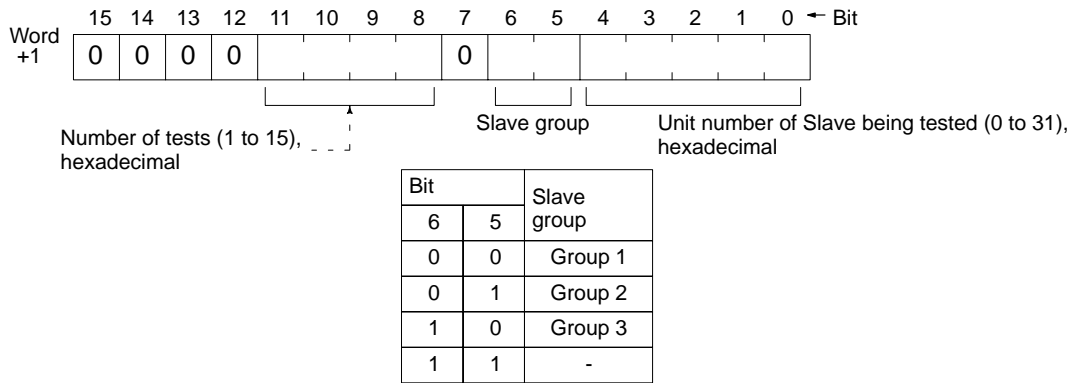

Slave Communications Stop/Restart Words (p. 63)

CIO 1500 + (25 x Unit Number) + (2 to 5)

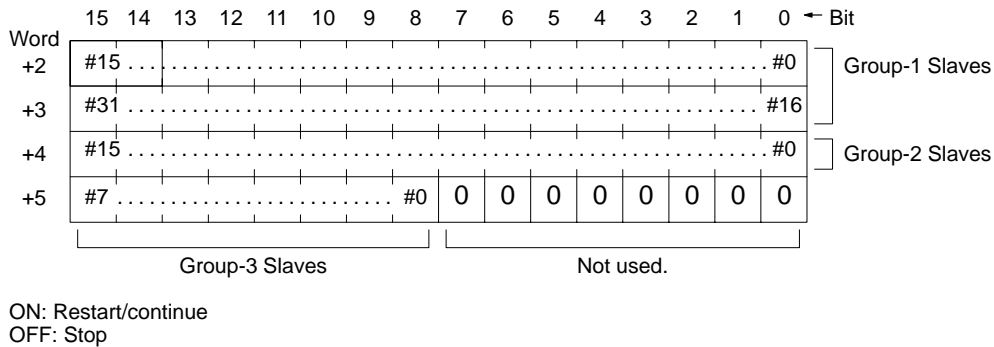

Remote Status Word (p. 58; Circuits: p. 98)

CIO 1500 + (25 x Unit Number) + 6

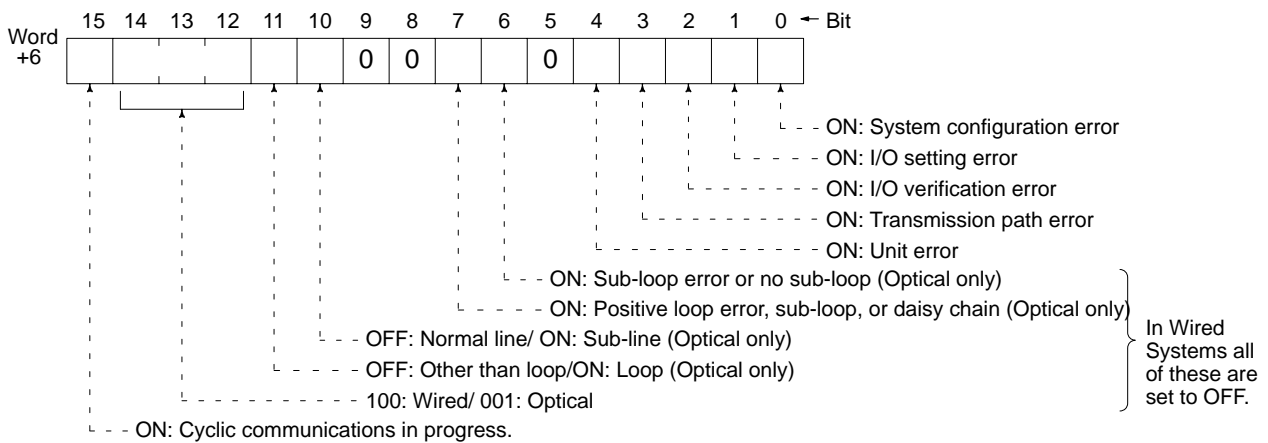

Terminator Status/Transmission Path Status Word (p. 59)

CIO 1500 + (25 x Unit Number) + 7

Terminator Status (Wired)

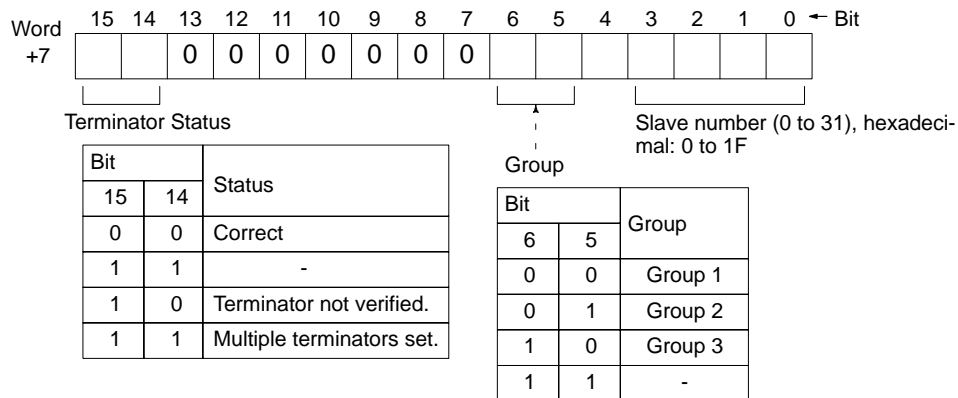

Transmission Path Status (Optical)

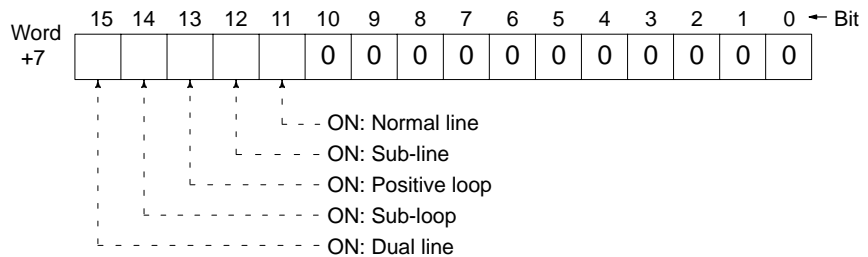

Communications Test Results Word (p. 66)

CIO 1500 + (25 x Unit Number) + 8

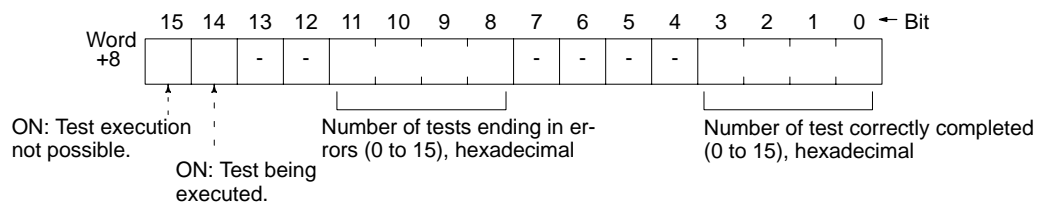

Active Slave Status Words (p. 60)

CIO 1500 + (25 x Unit Number) + (9 to 12)

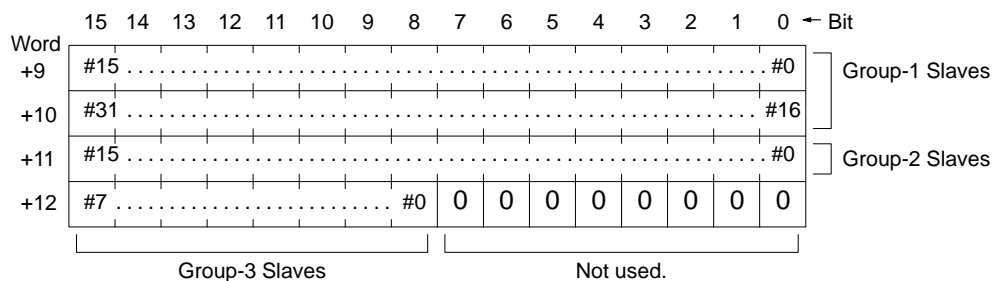

ON: Active
OFF: Not active

RUN/Maintenance Status (p. 61)

CIO 1500 + (25 x Unit Number) + (13 to 16)

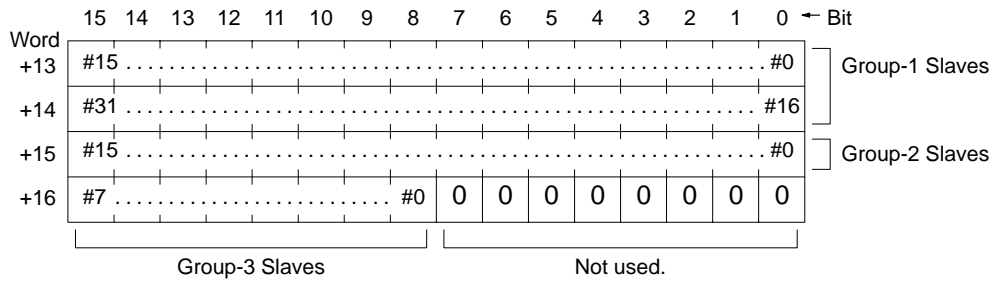

ON: RUN mode
 OFF: Other than RUN mode (not communicating)

Applications Error Word (p. 61)

CIO 1500 + (25 x Unit Number) + (17 to 20)

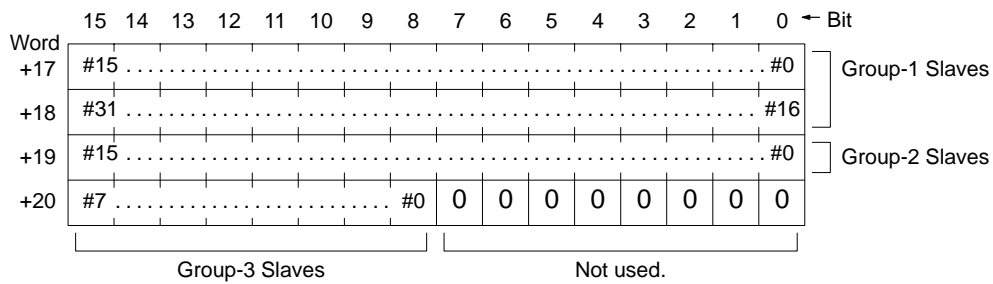

ON: Applications error
 OFF: Application normal

Transmission Error Word (p. 62)

CIO 1500 + (25 x Unit Number) + (21 to 24)

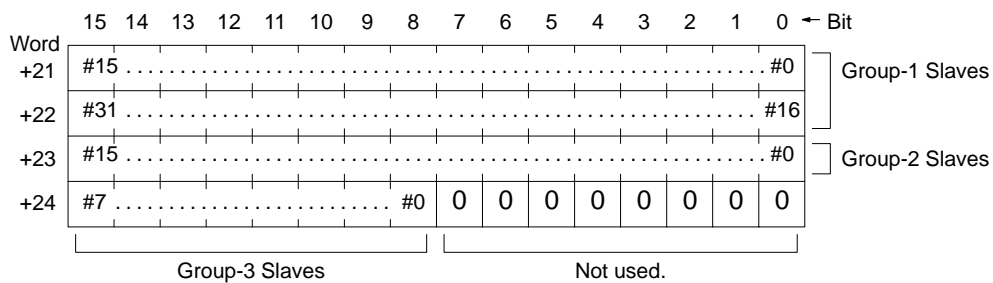

ON: Transmission error
 OFF: Transmission normal

Appendix D

Auxiliary Area

This appendix provides information on the words and bits in the Auxiliary Area that are used with SYSMAC BUS/2 Remote I/O Systems. The information is provided for reference only and only words related to SYSMAC BUS/2 Remote I/O Systems are listed. Refer to the *CV-series PC Operation Manual: Ladder Diagrams* for details on memory areas and ladder-diagram programming.

The Auxiliary Area contains flags and control bits used for monitoring and controlling PC operation, accessing clock pulses, and signalling errors. Auxiliary Area word addresses range from A000 through A511; bit addresses, from A00000 through A51115. Addresses A000 through A255 are read/write, but addresses A256 through A511 are read-only.

| Word(s) | Bit(s) | Function |
|--------------|----------|---|
| A001 | 00 to 15 | CPU Bus Unit Restart Bits |
| A015 | 00 to 15 | CPU Bus Service Disable Bits |
| A302 | 00 to 15 | CPU Bus Unit Initializing Flags |
| A306 | 00 | Start Input Wait Flag |
| | 03 | CPU Bus Unit Initializing Wait Flag |
| A307 | 00 to 07 | Peripheral Connected Flags for RT #0 to RT #7 of RM/2 #0 |
| | 08 to 15 | Peripheral Connected Flags for RT #0 to RT #7 of RM/2 #1 |
| A308 | 00 to 07 | Peripheral Connected Flags for RT #0 to RT #7 of RM/2 #2 |
| | 08 to 15 | Peripheral Connected Flags for RT #0 to RT #7 of RM/2 #3 |
| A310 to A325 | 00 to 15 | CPU Bus Unit Service Interval (binary) |
| A401 | 11 | Too Many I/O Points Flag |
| | 12 | CPU Bus Error Flag |
| A402 | 03 | CPU Bus Unit Parameter Error Flag |
| | 06 | SYSMAC BUS/2 Error Flag |
| | 07 | CPU Bus Unit Error Flag |
| | 09 | I/O Verification Error Flag |
| A405 | 00 to 15 | CPU Bus Unit Error Unit Number |
| A408 | 00 to 15 | Total SYSMAC BUS/2 I/O Words (BCD) |
| A410 | 00 to 15 | CPU Bus Unit Duplicate Number |
| A422 | 00 to 15 | CPU Bus Unit Error Unit Number |
| A423 | 14 | CPU Bus Unit Number Setting Error Flag |
| | 15 | CPU Bus Link Error Flag |
| A424 | 00 to 03 | SYSMAC BUS/2 Error Master Number |
| A427 | 00 to 15 | CPU Bus Unit Parameter Error Unit Number |
| A480 to A499 | 00 to 15 | SYSMAC BUS/2 Error Unit Number: RM #0 (A480 to A484) RM #1 (A485 to A489) RM #2 (A490 to A494) RM #3 (A495 to A499) |

CPU Bus Unit Restart Bits

Bits **A00100 through A00115** can be turned ON to reset CPU Bus Units number #0 through #15, respectively. The Restart Bits are turned OFF automatically when restarting is completed.

Do not turn these bits ON and OFF in the program; manipulate them from the CVSS.

Service Disable Bits

Bits **A01500 through A01515** can be turned ON to stop service to CPU Bus Units numbered #0 through #15, respectively. Turn the appropriate bit OFF again to resume service to the CPU Bus Unit.

CPU Bus Unit Initializing Flags

Bits **A30200 through A30215** turn ON while the corresponding CPU Bus Units (Units #0 through #15, respectively) are initializing.

CPU Bus Unit Initializing Wait Flag

Bit **A30603** is ON when the PC is not running because a CPU Bus Unit is initializing, or a terminator missing in the SYSMAC BUS/2 System.

SYSMAC BUS/2 Peripheral Flags

Bits **A30700 through A30815** are turned ON when a Peripheral Device is connected to the corresponding Slave Rack, as shown in the following table.

| Word | Bits 00 to 07 | Bits 08 to 15 |
|------|-----------------------------|-----------------------------|
| A307 | Racks #0 to #7 on Master #0 | Racks #0 to #7 on Master #1 |
| A308 | Racks #0 to #7 on Master #2 | Racks #0 to #7 on Master #3 |

CPU Bus Unit Service Interval

Words **A310 through A325** contain the interval in ms (binary) between CPU Bus Unit services for Units #0 through #15, respectively. Measuring the service interval can be enabled or disabled in the PC System Settings.

Too Many I/O Points Flag

Bit **A40111** is turned ON if the total number of I/O points being used exceeds the maximum for the PC. The total number of I/O points being used on CPU and Expansion Racks is written to word A407; in the SYSMAC BUS/2 system, to word A408; and in the SYSMAC BUS system, to word A478.

CPU Bus Error and Unit Flags

Bit **A40112** is turned ON when an error occurs during the transmission of data between the CPU and CPU Bus Units, or a WDT (watchdog timer) error occurs in a CPU Bus Unit. The unit number of the CPU Bus Unit involved is contained in word A405.

Bits **A40500 through A40515** correspond to CPU Bus Units #0 through #15, respectively. When a CPU Bus Error occurs, the bit corresponding to the unit number of the CPU Bus Unit involved is turned ON.

Duplication Error Flag and Duplicate Rack/CPU Bus Unit Numbers

Bit **A40113** is turned ON when two Racks are assigned the same rack number, two CPU Bus Units are assigned the same unit number, or the same words are allocated to more than one Rack or Unit in the PC System Settings. The duplicate CPU Bus Unit number is written to word A410.

Bits **A41000 through A41015** correspond to CPU Bus Units #0 through #15, respectively. When two CPU Bus Units have the same unit number, the bits corresponding to the unit numbers of the CPU Bus Units involved are turned ON.

CPU Bus Unit Parameter Error Flag and Unit Number

Bit **A40203** is turned ON when the CPU Bus Units actually installed differ from the Units registered in the I/O table. The unit number of the CPU Bus Unit involved is written to word A427.

Bits **A42700 through A42715** correspond to CPU Bus Units #0 through #15, respectively. When a error occurs, the bit corresponding to the unit number of the CPU Bus Unit involved is turned ON.

I/O Verification Error Flag

Bit **A40209** is turned ON when the Units mounted in the system disagree with the I/O table registered in the CPU. To ensure proper operation, PC operation should be stopped, Units checked, and the I/O table corrected whenever this flag goes ON.

SYSMAC BUS/2 Error Flag and Master/Unit Numbers

Bit **A40206** is turned ON when an error occurs during the transmission of data in the SYSMAC BUS/2 System. The number of the Master involved is written to word A424, and information about the Slave Unit(s) involved is written to words A480 through A499.

Bits **A42400 through A42403** are turned ON when the error involves Masters #0 through #3, respectively. Information identifying the Slave Unit(s) involved is contained in words **A480 through A499**, which are divided into four groups of five words, one group for each Master, as shown below.

| Words | Master number |
|--------------|---------------|
| A480 to A484 | 0 |
| A485 to A489 | 1 |
| A490 to A494 | 2 |
| A495 to A499 | 3 |

Bits are turned ON to indicate which of the group-1 Slaves, group-2 Slaves, or group-3 Slaves (Slave Racks) connected to the Master was involved in the error, as shown below.

| Word | Bits | Slave Unit |
|--------|----------|---------------------------------------|
| First | 00 to 15 | Group-1 Slaves #0 to #15 |
| Second | 00 to 15 | Group-1 Slaves #16 to #31 |
| Third | 00 to 15 | Group-2 Slaves #0 to #15 |
| Fourth | 00 to 07 | Group-3 Slaves (Slave Racks) #0 to #7 |
| | 08 to 15 | Not used. |
| Fifth | 00 to 15 | Not used |

CPU Bus Unit Error Flag and Unit Numbers

Bit **A40207** is turned ON when a parity error occurs during the transmission of data between the CPU and CPU Bus Units. The unit number of the CPU Bus Unit involved is written to word A422.

Bits **A42200 through A42215** correspond to CPU Bus Units #0 through #15, respectively. When a CPU Bus Unit Error occurs, the bit corresponding to the unit number of the CPU Bus Unit involved is turned ON.

CPU Bus Unit Number Setting Error Flag

Bit **A42314** is turned ON when a CPU Bus Unit is not set to an acceptable unit number (0 to 15).

CPU Bus Link Error Flag

Bit **A42315** is turned ON when a parity error occurs with CPU bus links.

Appendix E

Settings for and Restrictions in Executing READ(190)/WRIT(191)

Settings for READ(190)/WRIT(191)

Use the following setting for the CV500-RT221/RT211: 54MH

- Although there are three types of slave, 58M, 122M, and 54MH, READ(190)/WRIT(191) can be used only with the 54MH setting. If 58M or 122M is used, the ERR Flag (A50003) will turn ON if an attempt is made to execute READ(190)/WRIT(191) and the instruction will not be executed.
- The ERR Flag (A50003) will also turn ON and READ(190)/WRIT(191) will not be executed if the word specified in the READ(190)/WRIT(191) operand is not allocated to a Special I/O Unit.
- With the 54MH slave type, up to four slaves can be connected to one master.

Restrictions in Executing READ(190)/WRIT(191)

- The differentiated forms of READ(190)/WRIT(191) cannot be used for Special I/O Units mounted to SYSMAC BUS/2 Racks. The execution condition for READ(190)/WRIT(191) must be maintained until the = Flag (A50006) turns ON.
- Both READ(190) and WRIT(191) cannot be executed for the same Special I/O Unit at the same time. (When executing both, make sure that the WRIT(191) instruction has completed execution before executing the READ(190) instruction.)
- A maximum of two READ(190)/WRIT(191) instructions can be executed at the same time for one Master. If there are three or more Special I/O Units mounted to Slave Racks and two READ(190)/WRIT(191) instructions are already being executed, the CY Flag (A50004) will turn ON and the instruction will not be executed in an attempt is made to execute any other READ(190)/WRIT(191) instructions. Therefore, if for example, there are Units, such as Analog Input or Counter Units, for which the READ(190)/WRIT(191) instructions are to be executed continuously, then only two Special I/O Units can be mounted under one master.
- With the CV1000 or CV2000, a maximum of four Master Units can be mounted to one PLC. Therefore, the maximum number of READ(190)/WRIT(191) instructions that can be executed by one PLC for the maximum number of Master Units is eight.
- The maximum number for words that can be transferred for one READ(190)/WRIT(191) instruction is 255 words.

Glossary

| | |
|-------------------------------|--|
| address | A number used to identify the location of data or programming instructions in memory or to identify the location of a network or a unit in a network. |
| advanced instruction | An instruction input with a function code that handles data processing operations within ladder diagrams, as opposed to a basic instruction, which makes up the fundamental portion of a ladder diagram. |
| allocation | The process by which the PC assigns certain bits or words in memory for various functions. This includes pairing I/O bits to I/O points on Units. |
| analog | Something that represents or can process a continuous range of values as opposed to values that can be represented in distinct increments. Something that represents or can process values represented in distinct increments is called digital. |
| Analog I/O Unit | I/O Units that convert I/O between analog and digital values. An Analog Input Unit converts an analog input to a digital value for processing by the PC. An Analog Output Unit converts a digital value to an analog output. |
| AND | A logic operation whereby the result is true if and only if both premises are true. In ladder-diagram programming the premises are usually ON/OFF states of bits or the logical combination of such states called execution conditions. |
| area | See <i>data area</i> and <i>memory area</i> . |
| area prefix | A one or two letter prefix used to identify a memory area in the PC. All memory areas except the CIO area require prefixes to identify addresses in them. |
| ASCII | Short for American Standard Code for Information Interchange. ASCII is used to code characters for output to printers and other external devices. |
| asynchronous execution | Execution of programs and servicing operations in which program execution and servicing are not synchronized with each other. |
| Auxiliary Area | A PC data area allocated to flags and control bits. |
| auxiliary bit | A bit in the Auxiliary Area. |
| back-up | A copy made of existing data to ensure that the data will not be lost even if the original data is corrupted or erased. |
| BASIC | A common programming language. BASIC Units are programmed in BASIC. |
| basic instruction | A fundamental instruction used in a ladder diagram. See <i>advanced instruction</i> . |
| BASIC Unit | A CPU Bus Unit used to run programs in BASIC. |
| baud rate | The data transmission speed between two devices in a system measured in bits per second. |
| BCD | Short for binary-coded decimal. |
| binary | A number system where all numbers are expressed in base 2, i.e., numbers are written using only 0's and 1's. Each group of four binary bits is equivalent to one |

| | |
|--------------------------------------|---|
| | hexadecimal digit. Binary data in memory is thus often expressed in hexadecimal for convenience. |
| binary-coded decimal | A system used to represent numbers so that every four binary bits is numerically equivalent to one decimal digit. |
| bit | The smallest piece of information that can be represented on a computer. A bit has the value of either zero or one, corresponding to the electrical signals ON and OFF. A bit represents one binary digit. Some bits at particular addresses are allocated to special purposes, such as holding the status of input from external devices, while other bits are available for general use in programming. |
| bit address | The location in memory where a bit of data is stored. A bit address specifies the data area and word that is being addressed as well as the number of the bit within the word. |
| Branching Link Adapter | A Link Adapter used to branch connections to Units in a Link System used either to prevent the entire System from shutting down for an interruption at only one point in the System or to enable connecting more than two Units in one System when each Unit provides only one connector. |
| buffer | A temporary storage space for data in a computerized device. |
| building-block PC | A PC that is constructed from individual components, or "building blocks." With building-block PCs, there is no one Unit that is independently identifiable as a PC. The PC is rather a functional assembly of Units. |
| bus | A communications path used to pass data between any of the Units connected to it. |
| bus link | A data link that passed data between two Units across a bus. |
| byte | A unit of data equivalent to 8 bits, i.e., half a word. |
| central processing unit | A device that is capable of storing programs and data, and executing the instructions contained in the programs. In a PC System, the central processing unit executes the program, processes I/O signals, communicates with external devices, etc. |
| channel | See <i>word</i> . |
| character code | A numeric (usually binary) code used to represent an alphanumeric character. |
| checksum | A sum transmitted with a data pack in communications. The checksum can be recalculated from the received data to confirm that the data in the transmission has not been corrupted. |
| CIM | Computer integrated manufacturing; a process where one or more computers are used to control and integrate manufacturing processes. |
| CIO Area | A memory area used to control I/O and to store and manipulate data. CIO Area addresses do not require prefixes. |
| combined Link System | A control system that includes more than one of the following systems: Remote I/O System, SYSMAC Link System, Host Link System, or SYSMAC NET Link System. |
| common (link) parameter table | A table of settings in a SYSMAC LINK System that specifies what words are to be used in the data links for all PCs in the SYSMAC LINK System. See <i>refresh parameter table</i> . |

| | |
|----------------------------|--|
| common data | Data that is stored in a memory of a PC and which is shared by other PCs in the same the same system. Each PC has a specified section(s) of the area allocated to it. Each PC writes to the section(s) allocated to it and reads the sections allocated to the other PCs with which it shares the common data. |
| constant | An input for an operand in which the actual numeric value is specified. Constants can be input for certain operands in place of memory area addresses. Some operands must be input as constants. |
| control bit | A bit in a memory area that is set either through the program or via a Programming Device to achieve a specific purpose, e.g., a Restart Bit is turned ON and OFF to restart a Unit. |
| control signal | A signal sent from the PC to effect the operation of the controlled system. |
| Control System | All of the hardware and software components used to control other devices. A Control System includes the PC System, the PC programs, and all I/O devices that are used to control or obtain feedback from the controlled system. |
| controlled system | The devices that are being controlled by a PC System. |
| CPU | See <i>central processing unit</i> . |
| CPU Bus Unit | A special Unit used with CV-series PCs that mounts to the CPU bus. This connection to the CPU bus enables special data links, data transfers, and processing. |
| CPU Rack | The main Rack in a building-block PC, the CPU Rack contains the CPU, a Power Supply, and other Units. The CPU Rack, along with the Expansion CPU Rack, provides both an I/O bus and a CPU bus. |
| C-series PC | Any of the following PCs: C2000H, C1000H, C500, C200H, C40H, C28H, C20H, C60K, C60P, C40K, C40P, C28K, C28P, C20K, C20P, C120, or C20. |
| CTS | An acronym for clear-to-send, a signal used in communications between electronic devices to indicate that the receiver is ready to accept incoming data. |
| CV Support Software | A programming package run on an IBM PC/AT or compatible to serve as a Programming Device for CV-series PCs. |
| CV-mode | A form of communications useable only with CV-series PCs. See <i>C-mode</i> . |
| CV-series PC | Any of the following PCs: CV500, CV1000, CV2000, or CVM1 |
| CVSS | See <i>CV Support Software</i> . |
| cycle | One unit of processing performed by the CPU, including SFC/ladder program execution, peripheral servicing, I/O refreshing, etc. The cycle is called the scan with C-series PCs. |
| cycle time | The time required to complete one cycle of CPU processing. |
| data area | An area in the PC's memory that is designed to hold a specific type of data. |
| data length | In communications, the number of bits that is to be treated as one unit in data transmissions. |
| data link | An automatic data transmission operation that allows PCs or Units within PC to pass data back and forth via common data areas. |

Glossary

| | |
|----------------------------|---|
| data link area | A common data area established through a data link. |
| data link table | A table of settings kept in memory that specifies what words are to be part of a data link for all PCs involved in the link. |
| data register | A storage location in memory used to hold data. In CV-series PCs, data registers are used with or without index registers to hold data used in indirect addressing. |
| data sharing | An aspect of SYSMAC Link Systems and SYSMAC NET Link Systems in which common data areas or common data words are created between two or more PCs. |
| data transfer | Moving data from one memory location to another, either within the same device or between different devices connected via a communications line or network. |
| debug | A process by which a draft program is corrected until it operates as intended. Debugging includes both the removal of syntax errors, as well as the fine-tuning of timing and coordination of control operations. |
| decimal | A number system where numbers are expressed to the base 10. In a PC all data is ultimately stored in binary form, four binary bits are often used to represent one decimal digit, via a system called binary-coded decimal. |
| decrement | Decreasing a numeric value, usually by 1. |
| default | A value automatically set by the PC when the user does not specifically set another value. Many devices will assume such default conditions upon the application of power. |
| delimiter | A code sent during communications between devices to indicate the end of the current transmission, but not the end of the entire transmission. See <i>terminator</i> . |
| destination | The location where an instruction places the data on which it is operating, as opposed to the location from which data is taken for use in the instruction. The location from which data is taken is called the source. |
| digit | A unit of storage in memory that consists of four bits. |
| DIP switch | Dual in-line package switch, an array of pins in a signal package that is mounted to a circuit board and is used to set operating parameters. |
| distributed control | A automation concept in which control of each portion of an automated system is located near the devices actually being controlled, i.e., control is decentralized and 'distributed' over the system. Distributed control is a concept basic to PC Systems. |
| DM Area | A data area used to hold only word data. Words in the DM area cannot be accessed bit by bit. |
| DM word | A word in the DM Area. |
| downloading | The process of transferring a program or data from a higher-level or host computer to a lower-level or slave computer. If a Programming Device is involved, the Programming Device is considered the host computer. |
| EEPROM | Electrically erasable programmable read-only memory; a type of ROM in which stored data can be erased and reprogrammed. This is accomplished using a |

| | |
|---------------------------|--|
| | special control lead connected to the EEPROM chip and can be done without having to remove the EEPROM chip from the device in which it is mounted. |
| electrical noise | Random variations of one or more electrical characteristics such as voltage, current, and data, which might interfere with the normal operation of a device. |
| EM Area | Extended Data Memory Area; an area that can be optionally added to certain PCs to enable greater data storage. Functionally, the EM Area operates like the DM Area. Area addresses are prefixed with E and only words can be accessed. The EM Area is separated into multiple banks. |
| EPROM | Erasable programmable read-only memory; a type of ROM in which stored data can be erased, by ultraviolet light or other means, and reprogrammed. |
| error code | A numeric code generated to indicate that an error exists, and something about the nature of the error. Some error codes are generated by the system; others are defined in the program by the operator. |
| even parity | A communication setting that adjusts the number of ON bits so that it is always even. See <i>parity</i> . |
| event processing | Processing that is performed in response to an event, e.g., an interrupt signal. |
| Expansion CPU Rack | A Rack connected to the CPU Rack to increase the virtual size of the CPU Rack. Units that may be mounted to the CPU Backplane may also be mounted to the Expansion CPU Backplane. |
| Expansion I/O Rack | A Rack used to increase the I/O capacity of a PC. In CV-Series PC, either one Expansion I/O Rack can be connected directly to the CPU or Expansion CPU Rack or multiple Expansion I/O Racks can be connected by using an I/O Control and I/O Interface Units. |
| FA | Factory automation. |
| factory computer | A general-purpose computer, usually quite similar to a business computer, that is used in automated factory control. |
| fatal error | An error that stops PC operation and requires correction before operation can continue. |
| FCS | See <i>frame checksum</i> . |
| FINS | See <i>CV-mode</i> . |
| flag | A dedicated bit in memory that is set by the system to indicate some type of operating status. Some flags, such as the carry flag, can also be set by the operator or via the program. |
| force reset | The process of forcibly turning OFF a bit via a programming device. Bits are usually turned OFF as a result of program execution. |
| force set | The process of forcibly turning ON a bit via a programming device. Bits are usually turned ON as a result of program execution. |
| frame checksum | The results of exclusive ORing all data within a specified calculation range. The frame checksum can be calculated on both the sending and receiving end of a data transfer to confirm that data was transmitted correctly. |

| | |
|------------------------------------|--|
| GPC | An acronym for Graphic Programming Console. |
| Graphic Programming Console | A programming device with advanced programming and debugging capabilities to facilitate PC operation. A Graphic Programming Console is provided with a large display onto which ladder-diagram programs can be written directly in ladder-diagram symbols for input into the PC without conversion to mnemonic form. |
| handshaking | The process whereby two devices exchange basic signals to coordinate communications between them. |
| header code | A code in an instruction that specifies what the instruction is to do. |
| hexadecimal | A number system where all numbers are expressed to the base 16. In a PC all data is ultimately stored in binary form, however, displays and inputs on Programming Devices are often expressed in hexadecimal to simplify operation. Each group of four binary bits is numerically equivalent to one hexadecimal digit. |
| host interface | An interface that allows communications with a host computer. |
| Host Link System | A system with one or more host computers connected to one or more PCs via Host Link Units or host interfaces so that the host computer can be used to transfer data to and from the PC(s). Host Link Systems enable centralized management and control of PC Systems. |
| Host Link Unit | An interface used to connect a C-series PC to a host computer in a Host Link System. |
| I/O allocation | The process by which the PC assigns certain bits in memory for various functions. This includes pairing I/O bits to I/O points on Units. |
| I/O Block | Either an Input Block or an Output Block. I/O Blocks provide mounting positions for replaceable relays. |
| I/O Control Unit | A Unit mounted to the CPU Rack to monitor and control I/O points on Expansion CPU Racks or Expansion I/O Racks. |
| I/O delay | The delay in time from when a signal is sent to an output to when the status of the output is actually in effect or the delay in time from when the status of an input changes until the signal indicating the change in the status is received. |
| I/O device | A device connected to the I/O terminals on I/O Units, Special I/O Units, etc. I/O devices may be either part of the Control System, if they function to help control other devices, or they may be part of the controlled system. |
| I/O Interface Unit | A Unit mounted to an Expansion CPU Rack or Expansion I/O Rack to interface the Rack to the CPU Rack. |
| I/O point | The place at which an input signal enters the PC System, or at which an output signal leaves the PC System. In physical terms, I/O points correspond to terminals or connector pins on a Unit; in terms of programming, an I/O points correspond to I/O bits in the IR area. |
| I/O refreshing | The process of updating output status sent to external devices so that it agrees with the status of output bits held in memory and of updating input bits in memory so that they agree with the status of inputs from external devices. |
| I/O response time | The time required for an output signal to be sent from the PC in response to an input signal received from an external device. |

| | |
|--------------------------------|--|
| I/O Terminal | A Remote I/O Unit connected in a Wired Remote I/O System to provide a limited number of I/O points at one location. There are several types of I/O Terminals. |
| I/O Unit | The most basic type of Unit mounted to a Backplane. I/O Units include Input Units and Output Units, each of which is available in a range of specifications. I/O Units do not include Special I/O Units, Link Units, etc. |
| I/O verification error | A error generated by a disagreement between the Units registered in the I/O table and the Units actually mounted to the PC. |
| I/O word | A word in the CIO area that is allocated to a Unit in the PC System and is used to hold I/O status for that Unit. |
| IBM PC/AT or compatible | A computer that has similar architecture to, that is logically compatible with, and that can run software designed for an IBM PC/AT computer. |
| initialize | Part of the startup process whereby some memory areas are cleared, system setup is checked, and default values are set. |
| input | The signal coming from an external device into the PC. The term input is often used abstractly or collectively to refer to incoming signals. |
| input bit | A bit in the CIO area that is allocated to hold the status of an input. |
| Input Block | A Unit used in combination with a Remote Interface to create an I/O Terminal. An Input Block provides mounting positions for replaceable relays. Each relay can be selected according to specific input requirements. |
| input device | An external device that sends signals into the PC System. |
| input point | The point at which an input enters the PC System. Input points correspond physically to terminals or connector pins. |
| input signal | A change in the status of a connection entering the PC. Generally an input signal is said to exist when, for example, a connection point goes from low to high voltage or from a nonconductive to a conductive state. |
| Input Terminal | An I/O Terminal that provides input points. |
| instruction | A direction given in the program that tells the PC of the action to be carried out, and the data to be used in carrying out the action. Instructions can be used to simply turn a bit ON or OFF, or they can perform much more complex actions, such as converting and/or transferring large blocks of data. |
| interface | An interface is the conceptual boundary between systems or devices and usually involves changes in the way the communicated data is represented. Interface devices such as NSBs perform operations like changing the coding, format, or speed of the data. |
| interrupt (signal) | A signal that stops normal program execution and causes a subroutine to be run or other processing to take place. |
| Interrupt Input Unit | A Rack-mounting Unit used to input external interrupts into a PC System. |
| IOIF | An acronym for I/O Interface Unit. |
| IOM (Area) | A collective memory area containing all of the memory areas that can be accessed by bit, including timer and counter Completion Flags. The IOM Area includes all memory area memory addresses between 0000 and 0FFF. |

| | |
|-------------------------------------|--|
| JIS | An acronym for Japanese Industrial Standards. |
| jump | A type of programming where execution moves directly from one point in a program to another, without sequentially executing any instructions in between. Jumps in ladder diagrams are usually conditional on an execution condition; jumps in SFC programs are conditional on the step status and transition condition status before the jump. |
| LAN | An acronym for local area network. |
| least-significant (bit/word) | See <i>rightmost (bit/word)</i> . |
| LED | Acronym for light-emitting diode; a device used as for indicators or displays. |
| leftmost (bit/word) | The highest numbered bits of a group of bits, generally of an entire word, or the highest numbered words of a group of words. These bits/words are often called most-significant bits/words. |
| link | A hardware or software connection formed between two Units. "Link" can refer either to a part of the physical connection between two Units or a software connection created to data existing at another location (i.e., data links). |
| link parameter table | See <i>common link parameter table</i> . |
| Link System | A system used to connect remote I/O or to connect multiple PCs in a network. Link Systems include the following: SYSMAC BUS Remote I/O Systems, SYSMAC BUS/2 Remote I/O Systems, SYSMAC LINK Systems, Host Link Systems, and SYSMAC NET Link Systems. |
| Link Unit | Any of the Units used to connect a PC to a Link System. These include Remote I/O Units, SYSMAC LINK Units, and SYSMAC NET Link Units. |
| load | The processes of copying data either from an external device or from a storage area to an active portion of the system such as a display buffer. Also, an output device connected to the PC is called a load. |
| local area network | A network consisting of nodes or positions in a loop arrangement. Each node can be any one of a number of devices. This kind of network usually operates over a small area such as a group of offices or a factory floor. |
| local network table | A table that specifies all of the networks that a PC belongs to and the unit numbers of the Units connecting the PC to each of these networks. |
| master | In a SYSMAC NET Link System, a Unit specified to manage network communications. |
| master number | A number assigned to a master in a SYSMAC NET Link System. This number is different from the unit number. |
| MCR Unit | Magnetic Card Reader Unit. |
| megabyte | A unit of storage equal to one million bytes. |
| memory area | Any of the areas in the PC used to hold data or programs. |
| most-significant (bit/word) | See <i>leftmost (bit/word)</i> . |
| nesting | Programming one loop within another loop, programming a call to a subroutine within another subroutine, or programming an IF–ELSE programming section within another IF–ELSE section. |

| | |
|------------------------------|---|
| Network Service Board | A device with an interface to connect devices other than PCs to a SYSMAC NET Link System. |
| Network Service Unit | A Unit that provides two interfaces to connect peripheral devices to a SYSMAC NET Link System. |
| network support table | Tables of settings used to establish operating parameters for SYSMAC LINK and SYSMAC NET Link Systems. |
| node | One of the positions in a LAN. Each node incorporates a device that can communicate with the devices at all of the other nodes. The device at a node is identified by the node number. |
| node number | A number used to identify a node on a network. The node number of a CV-series PC is called the "unit number" in the PC Setup. |
| noise interference | Disturbances in signals caused by electrical noise. |
| nonfatal error | A hardware or software error that produces a warning but does not stop the PC from operating. |
| NOT | A logic operation which inverts the status of the operand. For example, AND NOT indicates an AND operation with the opposite of the actual status of the operand bit. |
| NSB | An acronym for Network Service Board. |
| NSU | An acronym for Network Service Unit. |
| octal | A number system where all numbers are expressed in base 8, i.e., numbers are written using only numerals 0 through 7. |
| odd parity | A communications setting that adjusts the number of ON bits so that it is always odd. See <i>parity</i> . |
| OFF | The status of an input or output when a signal is said not to be present. The OFF state is generally represented by a low voltage or by non-conductivity, but can be defined as the opposite of either. |
| OFF delay | The delay between the time when a signal is switched OFF (e.g., by an input device or PC) and the time when the signal reaches a state readable as an OFF signal (i.e., as no signal) by a receiving party (e.g., output device or PC). |
| offset | A positive or negative value added to a base value such as an address to specify a desired value. |
| ON | The status of an input or output when a signal is said to be present. The ON state is generally represented by a high voltage or by conductivity, but can be defined as the opposite of either. |
| ON delay | The delay between the time when an ON signal is initiated (e.g., by an input device or PC) and the time when the signal reaches a state readable as an ON signal by a receiving party (e.g., output device or PC). |
| operand | The values designated as the data to be used for an instruction. An operand can be input as a constant expressing the actual numeric value to be used or as an address to express the location in memory of the data to be used. |

| | |
|-------------------------------|---|
| operating error | An error that occurs during actual PC operation as opposed to an initialization error, which occurs before actual operations can begin. |
| optical communications | A communications method in which signals are sent over optical fiber cable to prevent noise interference and increase transmission distance. |
| OR | A logic operation whereby the result is true if either of two premises is true, or if both are true. In ladder-diagram programming the premises are usually ON/OFF states of bits or the logical combination of such states called execution conditions. |
| output | The signal sent from the PC to an external device. The term output is often used abstractly or collectively to refer to outgoing signals. |
| Output Block | A Unit used in combination with a Remote Interface to create an I/O Terminal. An Output Block provides mounting positions for replaceable relays. Each relay can be selected according to specific output requirements. |
| output device | An external device that receives signals from the PC System. |
| output point | The point at which an output leaves the PC System. Output points correspond physically to terminals or connector pins. |
| output signal | A signal being sent to an external device. Generally an output signal is said to exist when, for example, a connection point goes from low to high voltage or from a nonconductive to a conductive state. |
| Output Terminal | An I/O Terminal that provides output points. |
| overflow | The state where the capacity of a data storage location has been exceeded. |
| overwrite | Changing the content of a memory location so that the previous content is lost. |
| parity | Adjustment of the number of ON bits in a word or other unit of data so that the total is always an even number or always an odd number. Parity is generally used to check the accuracy of data after being transmitted by confirming that the number of ON bits is still even or still odd. |
| parity check | Checking parity to ensure that transmitted data has not been corrupted. |
| PC | An acronym for Programmable Controller. |
| PC configuration | The arrangement and interconnections of the Units that are put together to form a functional PC. |
| PC System | With building-block PCs, all of the Racks and independent Units connected directly to them up to, but not including the I/O devices. The boundaries of a PC System are the PC and the program in its CPU at the upper end; and the I/O Units, Special I/O Units, Optical I/O Units, Remote Terminals, etc., at the lower end. |
| PCB | An acronym for printed circuit board. |
| PC Setup | A group of operating parameters set in the PC from a Programming Device to control PC operation. |
| Peripheral Device | Devices connected to a PC System to aid in system operation. Peripheral devices include printers, programming devices, external storage media, etc. |

| | |
|--------------------------------|---|
| peripheral servicing | Processing signals to and from peripheral devices, including refreshing, communications processing, interrupts, etc. |
| PID Unit | A Unit designed for PID control. |
| polling | The process whereby a devices consecutively sends signals to other devices in the same network to pass data back and forth, e.g., as in a data link. |
| present value | The current value registered in a device at any instant during its operation. Present value is abbreviated as PV. The use of this term is generally restricted to timers and counters. |
| printed circuit board | A board onto which electrical circuits are printed for mounting into a computer or electrical device. |
| Programmable Controller | A computerized device that can accept inputs from external devices and generate outputs to external devices according to a program held in memory. Programmable Controllers are used to automate control of external devices. Although single-unit Programmable Controllers are available, building-block Programmable Controllers are constructed from separate components. Such Programmable Controllers are formed only when enough of these separate components are assembled to form a functional assembly, i.e., there is no one individual Unit called a PC. |
| Programming Console | The simplest form of programming device available for a PC. Programming Consoles are available both as hand-held models and as CPU-mounting models. |
| Programming Device | A Peripheral Device used to input a program into a PC or to alter or monitor a program already held in the PC. There are dedicated programming devices, such as Programming Consoles, and there are non-dedicated devices, such as a host computer. |
| PROM | Programmable read-only memory; a type of ROM into which the program or data may be written after manufacture, by a customer, but which is fixed from that time on. |
| PROM Writer | A peripheral device used to write programs and other data into a ROM for permanent storage and application. |
| prompt | A message or symbol that appears on a display to request input from the operator. |
| protocol | The parameters and procedures that are standardized to enable two devices to communicate or to enable a programmer or operator to communicate with a device. |
| PV | See <i>present value</i> . |
| Rack | An assembly that forms a functional unit in a Rack PC System. A Rack consists of a Backplane and the Units mounted to it. These Units include the Power Supply, CPU, and I/O Units. Racks include CPU Racks, Expansion I/O Racks, and I/O Racks. The CPU Rack is the Rack with the CPU mounted to it. An Expansion I/O Rack is an additional Rack that holds extra I/O Units. An I/O Rack is used in the C2000H Duplex System, because there is no room for any I/O Units on the CPU Rack in this System. |
| rack number | A number assigned to a Rack according to the order that it is connected to the CPU Rack, with the CPU Rack generally being rack number 0. |

| | |
|----------------------------------|--|
| Rack PC | A PC that is composed of Units mounted to one or more Racks. This configuration is the most flexible, and most large PCs are Rack PCs. A Rack PC is the opposite of a Package-type PC, which has all of the basic I/O, storage, and control functions built into a single package. |
| RAM | Random access memory; a data storage media. RAM will not retain data when power is disconnected. |
| RAS | An acronym for reliability, assurance, safety. |
| refresh | The process of updating output status sent to external devices so that it agrees with the status of output bits held in memory and of updating input bits in memory so that they agree with the status of inputs from external devices. |
| refresh parameter (table) | A table of settings that specifies which words in the data links for a System are to be refreshed for a particular PC. See <i>common link parameter table</i> . |
| relay-based control | The forerunner of PCs. In relay-based control, groups of relays are interconnected to form control circuits. In a PC, these are replaced by programmable circuits. |
| reserved bit | A bit that is not available for user application. |
| reserved word | A word in memory that is reserved for a special purpose and cannot be accessed by the user. |
| reset | The process of turning a bit or signal OFF or of changing the present value of a timer or counter to its set value or to zero. |
| response code | A code sent with the response to a data transmission that specifies how the transmitted data was processed. |
| response format | A format specifying the data required in a response to a data transmission. |
| Restart Bit | A bit used to restart a Unit mounted to a PC. |
| restart continuation | A process which allows memory and program execution status to be maintained so that PC operation can be restarted from the state it was in when operation was stopped by a power interruption. |
| retrieve | The processes of copying data either from an external device or from a storage area to an active portion of the system such as a display buffer. Also, an output device connected to the PC is called a load. |
| retry | The process whereby a device will re-transmit data which has resulted in an error message from the receiving device. |
| rightmost (bit/word) | The lowest numbered bits of a group of bits, generally of an entire word, or the lowest numbered words of a group of words. These bits/words are often called least-significant bits/words. |
| rising edge | The point where a signal actually changes from an OFF to an ON status. |
| ROM | Read only memory; a type of digital storage that cannot be written to. A ROM chip is manufactured with its program or data already stored in it and can never be changed. However, the program or data can be read as many times as desired. |

| | |
|------------------------------|---|
| routing table | Tables of setting that specify what networks a device is a member of and what nodes must be passed through to reach other specific networks. See <i>local network table</i> and <i>relay network table</i> . |
| RS-232C interface | An industry standard for serial communications. |
| RS-422 interface | An industry standard for serial communications. |
| scan | The process used to execute a ladder-diagram program. The program is examined sequentially from start to finish and each instruction is executed in turn based on execution conditions. The scan also includes peripheral processing, I/O refreshing, etc. The scan is called the cycle with CV-series PCs. |
| scan time | The time required for a single scan of a ladder-diagram program. |
| self diagnosis | A process whereby the system checks its own operation and generates a warning or error if an abnormality is discovered. |
| series | A wiring method in which Units are wired consecutively in a string. In Link Systems wired through Link Adapters, the Units are still functionally wired in series, even though Units are placed on branch lines. |
| servicing | The process whereby the PC provides data to or receives data from external devices or remote I/O Units, or otherwise handles data transactions for Link Systems. |
| set | The process of turning a bit or signal ON. |
| set value | The value from which a decrementing counter starts counting down or to which an incrementing counter counts up (i.e., the maximum count), or the time from which or for which a timer starts timing. Set value is abbreviated SV. |
| software error | An error that originates in a software program. |
| software protect | A means of protecting data from being changed that uses software as opposed to a physical switch or other hardware setting. |
| software switch | See <i>memory switch</i> . |
| Special I/O Unit | A Unit that is designed for a specific purpose. Special I/O Units include Position Control Units, High-speed Counter Units, Analog I/O Units, etc. |
| SRAM | Static random access memory; a data storage media. |
| subroutine | A group of instructions placed separate from the main program and executed only when called from the main program or activated by an interrupt. |
| SV | Abbreviation for set value. |
| synchronous execution | Execution of programs and servicing operations in which program execution and servicing are synchronized so that all servicing operations are executed each time the programs are executed. |
| syntax | The form of a program statement (as opposed to its meaning). For example, the two statements, <code>LET A=B+B</code> and <code>LET A=B*2</code> use different syntaxes, but have the same meaning. |
| syntax error | An error in the way in which a program is written. Syntax errors can include 'spelling' mistakes (i.e., a function code that does not exist), mistakes in specifying |

ing operands within acceptable parameters (e.g., specifying read-only bits as a destination), and mistakes in actual application of instructions (e.g., a call to a subroutine that does not exist).

| | |
|-------------------------------|--|
| SYSMAC LINK System | A communications system used to create data links and enable network communications between PCs. |
| SYSMAC NET Link System | An optical LAN formed from PCs connected through SYSMAC NET Link Units. A SYSMAC NET Link System also normally contains nodes interfacing computers and other peripheral devices. PCs in the SYSMAC NET Link System can pass data back and forth, receive commands from any interfaced computer, and share any interfaced peripheral device. |
| SYSMAC NET Link Unit | The Unit used to connect PCs to a SYSMAC NET Link System. |
| system configuration | The arrangement in which Units in a System are connected. This term refers to the conceptual arrangement and wiring together of all the devices needed to comprise the System. In OMRON terminology, system configuration is used to describe the arrangement and connection of the Units comprising a Control System that includes one or more PCs. |
| system error | An error generated by the system, as opposed to one resulting from execution of an instruction designed to generate an error. |
| system error message | An error message generated by the system, as opposed to one resulting from execution of an instruction designed to generate a message. |
| terminator | The code comprising an asterisk and a carriage return (* CR) which indicates the end of a block of data in communications between devices. Frames within a multi-frame block are separated by delimiters. Also a Unit in a Link System designated as the last Unit on the communications line. |
| timer | A location in memory accessed through a TC bit and used to time down from the timer's set value. Timers are turned ON and reset according to their execution conditions. |
| TR Area | A data area used to store execution conditions so that they can be reloaded later for use with other instructions. |
| TR bit | A bit in the TR Area. |
| transfer | The process of moving data from one location to another within the PC, or between the PC and external devices. When data is transferred, generally a copy of the data is sent to the destination, i.e., the content of the source of the transfer is not changed. |
| transmission distance | The distance that a signal can be transmitted. |
| UM area | The memory area used to hold the active program, i.e., the program that is being currently executed. |
| Unit | In OMRON PC terminology, the word Unit is capitalized to indicate any product sold for a PC System. Though most of the names of these products end with the word Unit, not all do, e.g., a Remote Terminal is referred to in a collective sense as a Unit. Context generally makes any limitations of this word clear. |
| unit address | A number used to control network communications. Unit addresses are computed for Units in various ways, e.g., 10 hex is added to the unit number to determine the unit address for a CPU Bus Unit. |

Glossary

| | |
|-----------------------------|---|
| unit number | A number assigned to some Link Units, Special I/O Units, and CPU Bus Units to facilitate identification when assigning words or other operating parameters. |
| uploading | The process of transferring a program or data from a lower-level or slave computer to a higher-level or host computer. If a Programming Device is involved, the Programming Device is considered the host computer. |
| watchdog timer | A timer within the system that ensures that the scan time stays within specified limits. When limits are reached, either warnings are given or PC operation is stopped depending on the particular limit that is reached. |
| WDT | See <i>watchdog timer</i> . |
| wire communications | A communications method in which signals are sent over wire cable. Although noise resistance and transmission distance can sometimes be a problem with wire communications, they are still the cheapest and the most common, and perfectly adequate for many applications. |
| word | A unit of data storage in memory that consists of 16 bits. All data areas consists of words. Some data areas can be accessed only by words; others, by either words or bits. |
| word address | The location in memory where a word of data is stored. A word address must specify (sometimes by default) the data area and the number of the word that is being addressed. |
| word allocation | The process of assigning I/O words and bits in memory to I/O Units and terminals in a PC System to create an I/O Table. |
| work area | A part of memory containing work words/bits. |
| work bit | A bit in a work word. |
| work word | A word that can be used for data calculation or other manipulation in programming, i.e., a 'work space' in memory. A large portion of the IR area is always reserved for work words. Parts of other areas not required for special purposes may also be used as work words. |
| write protect switch | A switch used to write-protect the contents of a storage device, e.g., a floppy disk. If the hole on the upper left of a floppy disk is open, the information on this floppy disk cannot be altered. |
| write-protect | A state in which the contents of a storage device can be read but cannot be altered. |

Index

Numbers

- 7-segment display, 54
- changing display modes, 54
 - baud rate, 54, 57
 - error messages, 54, 56
 - Mode 1, 54, 55
 - Mode 2, 54, 55
 - Mode 3, 54, 56
 - Mode 4, 54, 56
 - switch readout, 54, 57
- user programs
 - general example 1, 76
 - general example 2, 77
 - setting display characters example 1, 77
 - setting display characters example 2, 78

A

- abbreviations, 8
- addresses, CPU Bus Units, 57
- alarm messages, CVSS, 89
- auxiliary area
 - bits, 119
 - words, 120

B

- bits
 - CPU Bus error, 120
 - CPU Bus Link error flag, 121
 - CPU Bus Unit error flag, 121
 - CPU Bus Unit flags, 120
 - CPU Bus Unit initializing, 120
 - CPU Bus Unit initializing wait, 120
 - CPU Bus Unit number, 120
 - CPU Bus Unit number setting error flag, 121
 - CPU Bus Unit numbers, 121
 - CPU Bus Unit parameter error flag, 120
 - CPU Bus Unit Restart, 119
 - duplicate Rack/CPU Bus Unit numbers, 120
 - duplication error flag, 120
 - I/O verification error flag, 120
 - service disable, 119
 - SYSMAC BUS/2, allocated, 93
 - SYSMAC BUS/2 error flag, 120
 - SYSMAC BUS/2 Master/Unit numbers, 120
 - SYSMAC BUS/2 peripheral flags, 120
 - too many I/O points flag, 120
- block diagrams
 - Masters, 113
 - Slaves, 113

C

- communications, 13
 - range, 5
- CPU Bus Units, 57
 - active Slave status words, 117
 - applications error word, 118
 - bits, 119–120
 - communications test results word, 117
 - communications test word, 116
 - communications tests
 - reading, 66
 - starting, 66
 - TS indicator, 67
 - control switch word, 62, 115
 - limitations, Slaves Racks, 16
 - operating status words, 58
 - active Slave status, 60
 - applications errors, 61
 - remote status, 58
 - RUN/maintenance status, 61
 - terminator status, 59
 - transmission path status, 60
 - transmissions errors, 62
 - remote status word, 116
 - restarting Master communications
 - from peripheral device, 65
 - from user program, 66
 - restarting Slave communications, 64
 - from user program, 64
 - RUN/maintenance status, 118
 - Slave communications stop/restart words, 116
 - stopping Master communications
 - from peripheral device, 65
 - from user program, 65
 - user program, 79
 - stopping Slave communications
 - from peripheral device, 63
 - from user program, 64
 - user program, 78
 - terminator status word, wired, 117
 - transmission error word, 118
 - transmission path status, optical, 117
 - word allocations, 115
- CPU Racks, limitations, examples, 21

D

- daisy chains, 19
- dimensions, 112
 - Remote I/O Master Units, 112
 - Remote I/O Slave Units, 112

E

- errors
 - 7-segment display, changing display modes, 54, 56
 - bits, 120–121
 - bits allocated, SYSMAC BUS/2 Slaves, 93
 - clearing
 - communications stop after an error, 101
 - restarting, 101
 - contents, SYSMAC BUS/2 support, 92
 - correcting
 - corrective measures, 94
 - line mode switching, 97
 - line modes, 98
 - transmission path, 94
 - CPU Bus Units
 - applications, 61
 - transmissions, 62
 - words, 118
 - CVSS, messages, 89
 - I/O tables
 - duplicated addresses, 105
 - overruns, 102
 - SYSMAC BUS/2 recognition, 101
 - unit numbers, 105
 - SYSMAC BUS/2 Master, 93
- Expansion Racks, limitations, examples, 22

F–I

- features, 5
- flags
 - CPU Bus Link error, 121
 - CPU Bus Units, 119–120
 - duplication error, 120–121
 - I/O verification error, 120–121
 - SYSMAC BUS/2, 120
 - too many I/O points, 120–121
- gateway, 4, 5
- GPC (Graphics Programming Console), 13
- I/O delays
 - calculations
 - asynchronous execution, 70
 - communications cycle time, 71
 - remote refresh time, 71
 - synchronous execution, 70
 - configuration, 70
 - program, 70
- I/O points
 - bits, 120
 - limitations
 - remote, 17
 - total, 17

L

- Link Units, 11

M–P

- models
 - connecting cables, 107
 - compatible Special I/O Units, 108
 - Optical Masters and Slaves, 108
 - wired Masters and Slaves, 107
 - CPU, 107
 - general, 107
 - Masters, 107
 - Slaves, 107
- numbers, 7
- PC, limitations, 12
- peripheral devices, limitations, examples, 24
- programming devices, 13
 - limitations, 16

R

- Racks, 6, 12
 - CPU, limitations examples, 21
 - Expansion, limitations examples, 22
- Remote I/O Master Units, 26
 - CPU Bus Connector, 26
 - CPU Bus Unit number, 39
 - ground for shield, 26
 - indicators, 26, 27
 - limitations, 12, 13
 - Master numbers, 40
 - optical connectors, 26
 - precautions, 43
 - transmission terminals, 26
 - unit number switch, 26
 - wiring, 30
 - word allocations, 40
- Remote I/O Slave Units, 28
 - See also* Slaves
 - DIP switch, 28
 - display, 28
 - display mode switch, 28
 - ground for shield, 28
 - I/O Bus Connector, 28
 - indicators, 28, 29
 - optical connectors, 28
 - peripheral device connector, 28
 - transmission terminals, 28
 - unit number switch, 28
 - wiring, 30
- Remote I/O System, settings, 74
 - connecting CVSS, 75
 - CPU
 - power, 75
 - Rack, 75
 - creating I/O tables, 75
 - CVSS system, 75
 - first word, 75
 - Master
 - general, 76
 - indicators, 75
 - switch, 75

- PC, 75
- PC Setup, 75
- Slave
 - indicators, 76
 - power, 75
 - Racks, 75
 - switch, 74
- transferring PC Setup, 75

S

- Slaves, 7, 11
 - See also* Remote I/O Slave Units
 - limitations, 14
 - Slaves Racks, 15
 - Unit numbers, 40
 - word allocations, 41
- Special I/O Units, limitations, 16
 - examples, 23
- specifications, 111
- SYSMAC BUS/2 Remote I/O System
 - bits, 120
 - in relation to other systems, 3
 - communications range, 5
 - gateway, 4
 - OMRON FA network systems, 3
 - overview, 2, 10, 38, 54
- system
 - configuration, general, 5
 - limitations, 13

T

- terminator switch, 48
 - DIP switch, 49
- terminology, 6
- transmission paths, 18
 - optical systems
 - daisy chains, 19
 - loops, 20
 - wired systems, 19
- troubleshooting
 - auxiliary area, 92
 - CVSS, 88
 - alarm messages, 89
 - error messages, 89

- flowcharts, 82
- Master indicators, 83
- Slave 7-segment displays, 88
- Slave indicators, 86
- SYSMAC BUS/2 support, 89
 - display status, 89
 - error contents, 92
 - reading Slave status, 91
 - Slave status regions, 92

U

- Unit settings
 - communications cycle time, 50
 - communications error processing, 50
 - error check, 50
 - hardware check, 49
 - response monitoring time, 51
 - transmission error count, 51
- Units, 6

W

- wiring, 30
 - optical systems, 30
 - daisy chaining, 32
 - loop connections, 32
 - precautions, 31
 - wired systems, 33
 - not using mounting brackets, 34
 - precautions, 34
 - using mounting brackets, 33
- word allocations, 38
 - basic, 38
 - CPU Bus Units, 115
 - examples, 43
 - Expansion CPU Rack and Slaves, 45
 - Expansion I/O Racks and Slaves, 46
 - mounting locations, 38
 - other CPU Bus Units, Special I/O Units, and Slaves, 47
 - Remote I/O Master Units, 40
 - Slaves, 41
 - Slaves only, 44
- words
 - CPU Bus Unit service interval, 120
 - CPU Bus Units, 115–118
 - control switch word, 62
 - operating status, 58–62

Revision History

A manual revision code appears as a suffix to the catalog number on the front cover of the manual.

Cat. No. W204-E1-03

↑
Revision code

The following table outlines the changes made to the manual during each revision. Page numbers refer to the previous version.

| Revision code | Date | Revised content |
|---------------|----------------|---|
| 1 | June 1992 | Original production |
| 2 | May 1993 | Minor changes to add CV2000 and CVM1. Page 33: Top diagram has been corrected for clarity. |
| 03 | September 2002 | Page 109: Models added to list of Special I/O Units and column removed from table. Page 121: Appendix E added. |

OMRON Corporation

FA Systems Division H.Q.

66 Matsumoto

Mishima-city, Shizuoka 411-8511

Japan

Tel: (81)55-977-9181/Fax: (81)55-977-9045

Regional Headquarters

OMRON EUROPE B.V.

Wegalaan 67-69, NL-2132 JD Hoofddorp

The Netherlands

Tel: (31)2356-81-300/Fax: (31)2356-81-388

OMRON ELECTRONICS LLC

1 East Commerce Drive, Schaumburg, IL 60173

U.S.A.

Tel: (1)847-843-7900/Fax: (1)847-843-8568

OMRON ASIA PACIFIC PTE. LTD.

83 Clemenceau Avenue,

#11-01, UE Square,

Singapore 239920

Tel: (65)6835-3011/Fax: (65)6835-2711

OMRON

Authorized Distributor:

Cat. No. W204-E1-03

SYSMAC BUS/2 CV-series Remote I/O

SYSTEM MANUAL

OMRON

Read and Understand this Manual

Please read and understand this manual before using the product. Please consult your OMRON representative if you have any questions or comments.

Warranty and Limitations of Liability

WARRANTY

OMRON's exclusive warranty is that the products are free from defects in materials and workmanship for a period of one year (or other period if specified) from date of sale by OMRON.

OMRON MAKES NO WARRANTY OR REPRESENTATION, EXPRESS OR IMPLIED, REGARDING NON-INFRINGEMENT, MERCHANTABILITY, OR FITNESS FOR PARTICULAR PURPOSE OF THE PRODUCTS. ANY BUYER OR USER ACKNOWLEDGES THAT THE BUYER OR USER ALONE HAS DETERMINED THAT THE PRODUCTS WILL SUITABLY MEET THE REQUIREMENTS OF THEIR INTENDED USE. OMRON DISCLAIMS ALL OTHER WARRANTIES, EXPRESS OR IMPLIED.

LIMITATIONS OF LIABILITY

OMRON SHALL NOT BE RESPONSIBLE FOR SPECIAL, INDIRECT, OR CONSEQUENTIAL DAMAGES, LOSS OF PROFITS OR COMMERCIAL LOSS IN ANY WAY CONNECTED WITH THE PRODUCTS, WHETHER SUCH CLAIM IS BASED ON CONTRACT, WARRANTY, NEGLIGENCE, OR STRICT LIABILITY.

In no event shall the responsibility of OMRON for any act exceed the individual price of the product on which liability is asserted.

IN NO EVENT SHALL OMRON BE RESPONSIBLE FOR WARRANTY, REPAIR, OR OTHER CLAIMS REGARDING THE PRODUCTS UNLESS OMRON'S ANALYSIS CONFIRMS THAT THE PRODUCTS WERE PROPERLY HANDLED, STORED, INSTALLED, AND MAINTAINED AND NOT SUBJECT TO CONTAMINATION, ABUSE, MISUSE, OR INAPPROPRIATE MODIFICATION OR REPAIR.

Application Considerations

SUITABILITY FOR USE

OMRON shall not be responsible for conformity with any standards, codes, or regulations that apply to the combination of products in the customer's application or use of the products.

At the customer's request, OMRON will provide applicable third party certification documents identifying ratings and limitations of use that apply to the products. This information by itself is not sufficient for a complete determination of the suitability of the products in combination with the end product, machine, system, or other application or use.

The following are some examples of applications for which particular attention must be given. This is not intended to be an exhaustive list of all possible uses of the products, nor is it intended to imply that the uses listed may be suitable for the products:

- Outdoor use, uses involving potential chemical contamination or electrical interference, or conditions or uses not described in this manual.
- Nuclear energy control systems, combustion systems, railroad systems, aviation systems, medical equipment, amusement machines, vehicles, safety equipment, and installations subject to separate industry or government regulations.
- Systems, machines, and equipment that could present a risk to life or property.

Please know and observe all prohibitions of use applicable to the products.

NEVER USE THE PRODUCTS FOR AN APPLICATION INVOLVING SERIOUS RISK TO LIFE OR PROPERTY WITHOUT ENSURING THAT THE SYSTEM AS A WHOLE HAS BEEN DESIGNED TO ADDRESS THE RISKS, AND THAT THE OMRON PRODUCTS ARE PROPERLY RATED AND INSTALLED FOR THE INTENDED USE WITHIN THE OVERALL EQUIPMENT OR SYSTEM.

PROGRAMMABLE PRODUCTS

OMRON shall not be responsible for the user's programming of a programmable product, or any consequence thereof.

Disclaimers

CHANGE IN SPECIFICATIONS

Product specifications and accessories may be changed at any time based on improvements and other reasons.

It is our practice to change model numbers when published ratings or features are changed, or when significant construction changes are made. However, some specifications of the products may be changed without any notice. When in doubt, special model numbers may be assigned to fix or establish key specifications for your application on your request. Please consult with your OMRON representative at any time to confirm actual specifications of purchased products.

DIMENSIONS AND WEIGHTS

Dimensions and weights are nominal and are not to be used for manufacturing purposes, even when tolerances are shown.

PERFORMANCE DATA

Performance data given in this manual is provided as a guide for the user in determining suitability and does not constitute a warranty. It may represent the result of OMRON's test conditions, and the users must correlate it to actual application requirements. Actual performance is subject to the OMRON Warranty and Limitations of Liability.

ERRORS AND OMISSIONS

The information in this manual has been carefully checked and is believed to be accurate; however, no responsibility is assumed for clerical, typographical, or proofreading errors, or omissions.