



MOTION CONTROLLER



Q series

Q170MCPU

User's Manual

● SAFETY PRECAUTIONS ●

(Please read these instructions before using this equipment.)

Before using this product, please read this manual and the relevant manuals introduced in this manual carefully and pay full attention to safety to handle the product correctly.

These precautions apply only to this product. Refer to the Users manual of the QCPU module to use for a description of the PLC system safety precautions.

In this manual, the safety instructions are ranked as "DANGER" and "CAUTION".



DANGER

Indicates that incorrect handling may cause hazardous conditions, resulting in death or severe injury.



CAUTION

Indicates that incorrect handling may cause hazardous conditions, resulting in medium or slight personal injury or physical damage.

Depending on circumstances, procedures indicated by  CAUTION may also be linked to serious results.

In any case, it is important to follow the directions for usage.

Please save this manual to make it accessible when required and always forward it to the end user.

For Safe Operations

1. Prevention of electric shocks

DANGER

- Never open the front case or terminal covers while the power is ON or the unit is running, as this may lead to electric shocks.
- Never run the unit with the front case or terminal cover removed. The high voltage terminal and charged sections will be exposed and may lead to electric shocks.
- Never open the front case or terminal cover at times other than wiring work or periodic inspections even if the power is OFF. The insides of the Motion controller and servo amplifier are charged and may lead to electric shocks.
- Completely turn off the externally supplied power used in the system before mounting or removing the module, performing wiring work, or inspections. Failing to do so may lead to electric shocks.
- When performing wiring work or inspections, turn the power OFF, wait at least ten minutes, and then check the voltage with a tester, etc.. Failing to do so may lead to electric shocks.
- Be sure to ground the Motion controller, servo amplifier and servomotor. (Ground resistance : 100 Ω or less) Do not ground commonly with other devices.
- The wiring work and inspections must be done by a qualified technician.
- Wire the units after installing the Motion controller, servo amplifier and servomotor. Failing to do so may lead to electric shocks or damage.
- Never operate the switches with wet hands, as this may lead to electric shocks.
- Do not damage, apply excessive stress, place heavy things on or sandwich the cables, as this may lead to electric shocks.
- Do not touch the Motion controller, servo amplifier or servomotor terminal blocks while the power is ON, as this may lead to electric shocks.
- Do not touch the built-in power supply, built-in grounding or signal wires of the Motion controller and servo amplifier, as this may lead to electric shocks.

2. For fire prevention

CAUTION

- Install the Motion controller, servo amplifier, servomotor and regenerative resistor on incombustible. Installing them directly or close to combustibles will lead to fire.
- If a fault occurs in the Motion controller or servo amplifier, shut the power OFF at the servo amplifier's power source. If a large current continues to flow, fire may occur.
- When using a regenerative resistor, shut the power OFF with an error signal. The regenerative resistor may abnormally overheat due to a fault in the regenerative transistor, etc., and may lead to fire.
- Always take heat measures such as flame proofing for the inside of the control panel where the servo amplifier or regenerative resistor is installed and for the wires used. Failing to do so may lead to fire.
- Do not damage, apply excessive stress, place heavy things on or sandwich the cables, as this may lead to fire.

3. For injury prevention

CAUTION

- Do not apply a voltage other than that specified in the instruction manual on any terminal. Doing so may lead to destruction or damage.
- Do not mistake the terminal connections, as this may lead to destruction or damage.
- Do not mistake the polarity (+ / -), as this may lead to destruction or damage.
- Do not touch the heat radiating fins of controller or servo amplifier, regenerative resistor and servomotor, etc., while the power is ON and for a short time after the power is turned OFF. In this timing, these parts become very hot and may lead to burns.
- Always turn the power OFF before touching the servomotor shaft or coupled machines, as these parts may lead to injuries.
- Do not go near the machine during test operations or during operations such as teaching. Doing so may lead to injuries.

4. Various precautions

Strictly observe the following precautions.

Mistaken handling of the unit may lead to faults, injuries or electric shocks.

(1) System structure

CAUTION

- Always install a leakage breaker on the Motion controller and servo amplifier power source.
- If installation of an electromagnetic contactor for power shut off during an error, etc., is specified in the instruction manual for the servo amplifier, etc., always install the electromagnetic contactor.
- Install the emergency stop circuit externally so that the operation can be stopped immediately and the power shut off.
- Use the Motion controller, servo amplifier, servomotor and regenerative resistor with the correct combinations listed in the instruction manual. Other combinations may lead to fire or faults.
- Use the Motion controller, base unit and motion module with the correct combinations listed in the instruction manual. Other combinations may lead to faults.
- If safety standards (ex., robot safety rules, etc.,) apply to the system using the Motion controller, servo amplifier and servomotor, make sure that the safety standards are satisfied.
- Construct a safety circuit externally of the Motion controller or servo amplifier if the abnormal operation of the Motion controller or servo amplifier differ from the safety directive operation in the system.
- In systems where coasting of the servomotor will be a problem during the forced stop, emergency stop, servo OFF or power supply OFF, use dynamic brakes.
- Make sure that the system considers the coasting amount even when using dynamic brakes.
- In systems where perpendicular shaft dropping may be a problem during the forced stop, emergency stop, servo OFF or power supply OFF, use both dynamic brakes and electromagnetic brakes.

CAUTION

- The dynamic brakes must be used only on errors that cause the forced stop, emergency stop, or servo OFF. These brakes must not be used for normal braking.
- The brakes (electromagnetic brakes) assembled into the servomotor are for holding applications, and must not be used for normal braking.
- The system must have a mechanical allowance so that the machine itself can stop even if the stroke limits switch is passed through at the max. speed.
- Use wires and cables that have a wire diameter, heat resistance and bending resistance compatible with the system.
- Use wires and cables within the length of the range described in the instruction manual.
- The ratings and characteristics of the parts (other than Motion controller, servo amplifier and servomotor) used in a system must be compatible with the Motion controller, servo amplifier and servomotor.
- Install a cover on the shaft so that the rotary parts of the servomotor are not touched during operation.
- There may be some cases where holding by the electromagnetic brakes is not possible due to the life or mechanical structure (when the ball screw and servomotor are connected with a timing belt, etc.). Install a stopping device to ensure safety on the machine side.

(2) Parameter settings and programming

CAUTION

- Set the parameter values to those that are compatible with the Motion controller, servo amplifier, servomotor and regenerative resistor model and the system application. The protective functions may not function if the settings are incorrect.
- The regenerative resistor model and capacity parameters must be set to values that conform to the operation mode, servo amplifier and servo power supply module. The protective functions may not function if the settings are incorrect.
- Set the mechanical brake output and dynamic brake output validity parameters to values that are compatible with the system application. The protective functions may not function if the settings are incorrect.
- Set the stroke limit input validity parameter to a value that is compatible with the system application. The protective functions may not function if the setting is incorrect.
- Set the servomotor encoder type (increment, absolute position type, etc.) parameter to a value that is compatible with the system application. The protective functions may not function if the setting is incorrect.
- Set the servomotor capacity and type (standard, low-inertia, flat, etc.) parameter to values that are compatible with the system application. The protective functions may not function if the settings are incorrect.
- Set the servo amplifier capacity and type parameters to values that are compatible with the system application. The protective functions may not function if the settings are incorrect.
- Use the program commands for the program with the conditions specified in the instruction manual.

CAUTION

- Set the sequence function program capacity setting, device capacity, latch validity range, I/O assignment setting, and validity of continuous operation during error detection to values that are compatible with the system application. The protective functions may not function if the settings are incorrect.
- Some devices used in the program have fixed applications, so use these with the conditions specified in the instruction manual.
- The input devices and data registers assigned to the link will hold the data previous to when communication is terminated by an error, etc. Thus, an error correspondence interlock program specified in the instruction manual must be used.
- Use the interlock program specified in the intelligent function module's instruction manual for the program corresponding to the intelligent function module.

(3) Transportation and installation

CAUTION

- Transport the product with the correct method according to the mass.
- Use the servomotor suspension bolts only for the transportation of the servomotor. Do not transport the servomotor with machine installed on it.
- Do not stack products past the limit.
- When transporting the Motion controller or servo amplifier, never hold the connected wires or cables.
- When transporting the servomotor, never hold the cables, shaft or detector.
- When transporting the Motion controller or servo amplifier, never hold the front case as it may fall off.
- When transporting, installing or removing the Motion controller or servo amplifier, never hold the edges.
- Install the unit according to the instruction manual in a place where the mass can be withstood.
- Do not get on or place heavy objects on the product.
- Always observe the installation direction.
- Keep the designated clearance between the Motion controller or servo amplifier and control panel inner surface or the Motion controller and servo amplifier, Motion controller or servo amplifier and other devices.
- Do not install or operate Motion controller, servo amplifiers or servomotors that are damaged or that have missing parts.
- Do not block the intake/outtake ports of the Motion controller, servo amplifier and servomotor with cooling fan.
- Do not allow conductive matter such as screw or cutting chips or combustible matter such as oil enter the Motion controller, servo amplifier or servomotor.
- The Motion controller, servo amplifier and servomotor are precision machines, so do not drop or apply strong impacts on them.
- Securely fix the Motion controller, servo amplifier and servomotor to the machine according to the instruction manual. If the fixing is insufficient, these may come off during operation.

⚠ CAUTION

- Always install the servomotor with reduction gears in the designated direction. Failing to do so may lead to oil leaks.
- Store and use the unit in the following environmental conditions.

Environment	Conditions	
	Motion controller/Servo amplifier	Servomotor
Ambient temperature	According to each instruction manual.	0°C to +40°C (With no freezing) (32°F to +104°F)
Ambient humidity	According to each instruction manual.	80% RH or less (With no dew condensation)
Storage temperature	According to each instruction manual.	-20°C to +65°C (-4°F to +149°F)
Atmosphere	Indoors (where not subject to direct sunlight). No corrosive gases, flammable gases, oil mist or dust must exist	
Altitude	1000m (3280.84ft.) or less above sea level	
Vibration	According to each instruction manual	

- When coupling with the synchronous encoder or servomotor shaft end, do not apply impact such as by hitting with a hammer. Doing so may lead to detector damage.
- Do not apply a load larger than the tolerable load onto the synchronous encoder and servomotor shaft. Doing so may lead to shaft breakage.
- When not using the module for a long time, disconnect the power line from the Motion controller or servo amplifier.
- Place the Motion controller and servo amplifier in static electricity preventing vinyl bags and store.
- When storing for a long time, please contact with our sales representative.
Also, execute a trial operation.

(4) Wiring

⚠ CAUTION

- Correctly and securely wire the wires. Reconfirm the connections for mistakes and the terminal screws for tightness after wiring. Failing to do so may lead to run away of the servomotor.
- After wiring, install the protective covers such as the terminal covers to the original positions.
- Do not install a phase advancing capacitor, surge absorber or radio noise filter (option FR-BIF) on the output side of the servo amplifier.
- Correctly connect the output side (terminal U, V, W) and ground. Incorrect connections will lead the servomotor to operate abnormally.
- Do not connect a commercial power supply to the servomotor, as this may lead to trouble.
- Do not mistake the direction of the surge absorbing diode installed on the DC relay for the control signal output of brake signals, etc. Incorrect installation may lead to signals not being output when trouble occurs or the protective functions not functioning.
- Do not connect or disconnect the connection cables between each unit, the encoder cable or PLC expansion cable while the power is ON.
- Securely tighten the cable connector fixing screws and fixing mechanisms. Insufficient fixing may lead to the cables combing off during operation.
- Do not bundle the power line or cables.

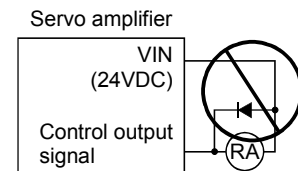

(5) Trial operation and adjustment

⚠ CAUTION

- Confirm and adjust the program and each parameter before operation. Unpredictable movements may occur depending on the machine.
- Extreme adjustments and changes may lead to unstable operation, so never make them.
- When using the absolute position system function, on starting up, and when the Motion controller or absolute value motor has been replaced, always perform a home position return.

(6) Usage methods

⚠ CAUTION

- Immediately turn OFF the power if smoke, abnormal sounds or odors are emitted from the Motion controller, servo amplifier or servomotor.
- Always execute a test operation before starting actual operations after the program or parameters have been changed or after maintenance and inspection.
- Do not attempt to disassemble and repair the units excluding a qualified technician whom our company recognized.
- Do not make any modifications to the unit.
- Keep the effect or electromagnetic obstacles to a minimum by installing a noise filter or by using wire shields, etc. Electromagnetic obstacles may affect the electronic devices used near the Motion controller or servo amplifier.
- When using the CE Mark-compliant equipment, refer to the "EMC Installation Guidelines" (data number IB(NA)-67339) for the Motion controllers and refer to the corresponding EMC guideline information for the servo amplifiers, inverters and other equipment.
- Use the units with the following conditions.

Item	Conditions
Input power	According to each instruction manual.
Input frequency	According to each instruction manual.
Tolerable momentary power failure	According to each instruction manual.

(7) Corrective actions for errors

⚠ CAUTION

- If an error occurs in the self diagnosis of the Motion controller or servo amplifier, confirm the check details according to the instruction manual, and restore the operation.
- If a dangerous state is predicted in case of a power failure or product failure, use a servomotor with electromagnetic brakes or install a brake mechanism externally.
- Use a double circuit construction so that the electromagnetic brake operation circuit can be operated by emergency stop signals set externally.

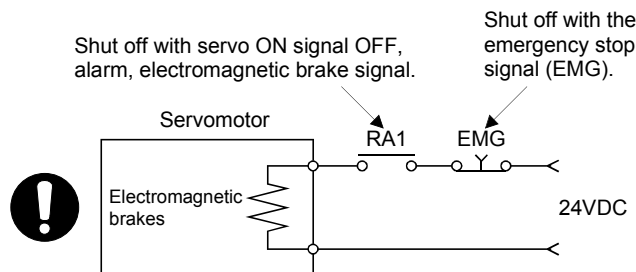

- If an error occurs, remove the cause, secure the safety and then resume operation after alarm release.
- The unit may suddenly resume operation after a power failure is restored, so do not go near the machine. (Design the machine so that personal safety can be ensured even if the machine restarts suddenly.)

(8) Maintenance, inspection and part replacement

CAUTION

- Perform the daily and periodic inspections according to the instruction manual.
- Perform maintenance and inspection after backing up the program and parameters for the Motion controller and servo amplifier.
- Do not place fingers or hands in the clearance when opening or closing any opening.
- Periodically replace consumable parts such as batteries according to the instruction manual.
- Do not touch the lead sections such as ICs or the connector contacts.
- Before touching the module, always touch grounded metal, etc. to discharge static electricity from human body. Failure to do so may cause the module to fail or malfunction.
- Do not directly touch the module's conductive parts and electronic components. Touching them could cause an operation failure or give damage to the module.
- Do not place the Motion controller or servo amplifier on metal that may cause a power leakage or wood, plastic or vinyl that may cause static electricity buildup.
- Do not perform a megger test (insulation resistance measurement) during inspection.
- When replacing the Motion controller or servo amplifier, always set the new module settings correctly.
- When the Motion controller or absolute value motor has been replaced, carry out a home position return operation using one of the following methods, otherwise position displacement could occur.
 - 1) After writing the servo data to the Motion controller using programming software, switch on the power again, then perform a home position return operation.
 - 2) Using the backup function of the programming software, load the data backed up before replacement.
- After maintenance and inspections are completed, confirm that the position detection of the absolute position detector function is correct.
- Do not drop or impact the battery installed to the module. Doing so may damage the battery, causing battery liquid to leak in the battery. Do not use the dropped or impacted battery, but dispose of it.
- Do not short circuit, charge, overheat, incinerate or disassemble the batteries.
- The electrolytic capacitor will generate gas during a fault, so do not place your face near the Motion controller or servo amplifier.
- The electrolytic capacitor and fan will deteriorate. Periodically replace these to prevent secondary damage from faults. Replacements can be made by our sales representative.
- Lock the control panel and prevent access to those who are not certified to handle or install electric equipment.
- Do not burn or break a module and servo amplifier. Doing so may cause a toxic gas.

(9) About processing of waste

When you discard Motion controller, servo amplifier, a battery (primary battery) and other option articles, please follow the law of each country (area).

 CAUTION

- This product is not designed or manufactured to be used in equipment or systems in situations that can affect or endanger human life.
- When considering this product for operation in special applications such as machinery or systems used in passenger transportation, medical, aerospace, atomic power, electric power, or submarine repeating applications, please contact your nearest Mitsubishi sales representative.
- Although this product was manufactured under conditions of strict quality control, you are strongly advised to install safety devices to forestall serious accidents when it is used in facilities where a breakdown in the product is likely to cause a serious accident.

(10) General cautions

- All drawings provided in the instruction manual show the state with the covers and safety partitions removed to explain detailed sections. When operating the product, always return the covers and partitions to the designated positions, and operate according to the instruction manual.

REVISIONS

* The manual number is given on the bottom left of the back cover.

Print Date	* Manual Number	Revision
Feb., 2009	IB(NA)-0300156-A	First edition

Japanese Manual Number IB(NA)-0300154

This manual confers no industrial property rights or any rights of any other kind, nor does it confer any patent licenses. Mitsubishi Electric Corporation cannot be held responsible for any problems involving industrial property rights which may occur as a result of using the contents noted in this manual.

INTRODUCTION

Thank you for choosing the Mitsubishi Motion controller Q170MCPU.
Before using the equipment, please read this manual carefully to develop full familiarity with the functions and performance of the Motion controller you have purchased, so as to ensure correct use.

CONTENTS

Safety Precautions	A- 1
Revisions	A-11
Contents	A-12
About Manuals	A-15

1. OVERVIEW	1- 1 to 1- 8
--------------------	---------------------

1.1 Overview.....	1- 1
1.2 Comparison between Q170MCPU and Q173DCPU/Q172DCPU	1- 3

2. SYSTEM CONFIGURATION	2- 1 to 2-54
--------------------------------	---------------------

2.1 Motion System Configuration	2- 1
2.1.1 Q170MCPU System overall configuration.....	2- 3
2.1.2 Q170MCPU System internal configuration	2- 4
2.1.3 Function explanation of the Q170MCPU Motion controller	2- 5
2.1.4 Restrictions on Motion controller	2- 6
2.2 Checking Serial Number and Operating System Software Version.....	2- 8
2.2.1 Checking serial number	2- 8
2.2.2 Checking operating system software version	2-10
2.3 System Configuration Equipment.....	2-11
2.4 General Specifications	2-16
2.5 Specifications of Equipment	2-17
2.5.1 Q170MCPU Motion controller.....	2-17
2.5.2. Extension base unit and extension cable.....	2-31
2.5.3 Q172DLX Servo external signals interface module	2-34
2.5.4 Q173DPX Manual pulse generator interface module	2-39
2.5.5 Manual pulse generator	2-47
2.5.6 SSCNET III cables	2-48
2.5.7 Battery	2-50
2.5.8 Forced stop input terminal	2-53

3. DESIGN	3- 1 to 3-16
------------------	---------------------

3.1 System Designing Procedure	3- 1
3.2 External Circuit Design	3- 4
3.2.1 Power supply circuit design	3- 7
3.2.2 Safety circuit design	3- 9
3.3 Layout Design within The Control Panel.....	3-11
3.3.1 Mounting environment.....	3-11
3.3.2 Calculating heat generation by Motion controller.....	3-12
3.4 Design Checklist	3-16

4. INSTALLATION AND WIRING	4- 1 to 4-28
-----------------------------------	---------------------

4.1 Module Installation	4- 1
4.1.1 Instructions for handling	4- 1
4.1.2 Instructions for mounting the modules	4- 3
4.1.3 Installation and removal of module to the base unit.....	4- 9
4.1.4 Mounting and removal of the battery holder.....	4-12
4.2 Connection and disconnection of Cable.....	4-17
4.2.1 SSCNET III cable	4-17
4.2.2 Forced stop input cable.....	4-23
4.2.3 24VDC power supply cable	4-24
4.3 Wiring.....	4-25
4.3.1 Instructions for wiring	4-25
4.3.2 Connecting to the power supply	4-28

5. START-UP PROCEDURES	5- 1 to 5-10
-------------------------------	---------------------

5.1 Check Items before Start-up.....	5- 1
5.2 Start-up Adjustment Procedure	5- 3
5.3 Operating System Software Installation Procedure.....	5- 7
5.4 Trial Operation and Adjustment Checklist.....	5- 9

6. INSPECTION AND MAINTENANCE	6- 1 to 6-30
--------------------------------------	---------------------

6.1 Maintenance Works	6- 2
6.1.1 Instruction of Inspection works	6- 2
6.2 Daily Inspection	6- 4
6.3 Periodic Inspection	6- 5
6.4 Life	6- 6
6.5 Battery	6- 7
6.5.1 Battery life.....	6- 8
6.5.2 Battery replacement procedure	6- 9
6.5.3 Resuming operation after storing the Motion controller	6-12
6.6 Troubleshooting	6-13
6.6.1 Troubleshooting basics	6-13
6.6.2 Troubleshooting of Motion controller	6-14
6.6.3 Confirming error code	6-30

7. POSITIONING DEDICATED SIGNALS	7- 1 to 7- 6
---	---------------------

7.1 Device List.....	7- 1
7.2 Positioning Dedicated Signals	7- 2
7.2.1 Internal Relays.....	7- 2
7.2.2 Data Registers.....	7- 4
7.2.3 Motion Registers	7- 5
7.2.4 Special Relays.....	7- 5
7.2.5 Special Registers	7- 5

APPENDIX 1 Differences Between Q170MCPU and Q173DCPU/Q172DCPU	APP- 1
APPENDIX 1.1 Differences of devices	APP- 2
APPENDIX 1.2 Differences of parameters.....	APP- 3
APPENDIX 1.3 Differences of programs.....	APP- 3
APPENDIX 1.4 Differences of error codes.....	APP- 5
APPENDIX 1.5 Differences of peripheral device interface	APP- 6
APPENDIX 1.6 Differences of CPU display and I/O assignment.....	APP-15
APPENDIX 2 Creation of project.....	APP-17
APPENDIX 2.1 Sample data.....	APP-18
APPENDIX 3 Processing Times.....	APP-32
APPENDIX 3.1 Processing time of operation control/Transition instruction	APP-32
APPENDIX 3.2 Processing time of Motion dedicated PLC instruction.....	APP-43
APPENDIX 4 Cables.....	APP-44
APPENDIX 4.1 SSCNET III cables.....	APP-44
APPENDIX 4.2 Forced stop input cable.....	APP-47
APPENDIX 4.3 24VDC power supply cable.....	APP-48
APPENDIX 5 Exterior Dimensions	APP-49
APPENDIX 5.1 Motion controller (Q170MCPU).....	APP-49
APPENDIX 5.2 Servo external signals interface module (Q172DLX).....	APP-50
APPENDIX 5.3 Manual pulse generator interface module (Q173DPX).....	APP-50
APPENDIX 5.4 Battery holder	APP-51
APPENDIX 5.5 Connector	APP-52
APPENDIX 5.6 Manual pulse generator (MR-HDP01).....	APP-53

About Manuals

The following manuals are also related to this product.

In necessary, order them by quoting the details in the tables below.

Related Manuals

(1) Motion controller

Manual Name	Manual Number (Model Code)
<p>Q170MCPU Motion controller User's Manual</p> <p>This manual explains specifications of the Q170MCPU Motion controller, Q172DLX Servo external signal interface module, Q173DPX Manual pulse generator interface module, Servo amplifiers, SSCNETⅢ cables, and the maintenance/inspection for the system, trouble shooting and others.</p> <p style="text-align: right;">(Optional)</p>	<p>IB-0300156 (1XB941)</p>
<p>Q173DCPU/Q172DCPU Motion controller Programming Manual (COMMON)</p> <p>This manual explains the Multiple CPU system configuration, performance specifications, common parameters, auxiliary/applied functions, error lists and others.</p> <p style="text-align: right;">(Optional)</p>	<p>IB-0300134 (1XB928)</p>
<p>Q173DCPU/Q172DCPU Motion controller (SV13/SV22) Programming Manual (Motion SFC)</p> <p>This manual explains the functions, programming, debugging, error lists for Motion SFC and others.</p> <p style="text-align: right;">(Optional)</p>	<p>IB-0300135 (1XB929)</p>
<p>Q173DCPU/Q172DCPU Motion controller (SV13/SV22) Programming Manual (REAL MODE)</p> <p>This manual explains the servo parameters, positioning instructions, device lists, error lists and others.</p> <p style="text-align: right;">(Optional)</p>	<p>IB-0300136 (1XB930)</p>
<p>Q173DCPU/Q172DCPU Motion controller (SV22) Programming Manual (VIRTUAL MODE)</p> <p>This manual explains the dedicated instructions to use the synchronous control by virtual main shaft, mechanical system program create mechanical module, servo parameters, positioning instructions, device lists, error lists and others.</p> <p style="text-align: right;">(Optional)</p>	<p>IB-0300137 (1XB931)</p>
<p>Motion controller Setup Guidance (MT Developer2 Version1)</p> <p>This manual explains the items related to the setup of the Motion controller programming software MT Developer2.</p>	<p>IB-0300142 (—)</p>

(2) PLC

Manual Name	Manual Number (Model Code)
<p>QCPU User's Manual (Hardware Design, Maintenance and Inspection)</p> <p>This manual explains the specifications of the QCPU modules, power supply modules, base units, extension cables, memory card battery, and the maintenance/inspection for the system, trouble shooting, error codes and others.</p> <p>(Optional)</p>	<p>SH-080483ENG (13JR73)</p>
<p>QnUCPU User's Manual (Function Explanation, Program Fundamentals)</p> <p>This manual explains the functions, programming methods and devices and others to create programs with the QCPU.</p> <p>(Optional)</p>	<p>SH-080807ENG (13JZ27)</p>
<p>QCPU User's Manual (Multiple CPU System)</p> <p>This manual explains the Multiple CPU system overview, system configuration, I/O modules, communication between CPU modules and communication with the I/O modules or intelligent function modules.</p> <p>(Optional)</p>	<p>SH-080485ENG (13JR75)</p>
<p>QCPU Programming Manual (Common Instructions)</p> <p>This manual explains how to use the sequence instructions, basic instructions, application instructions and micro computer program.</p> <p>(Optional)</p>	<p>SH-080809ENG (13JW10)</p>
<p>QCPU (Q Mode)/QnACPU Programming Manual (PID Control Instructions)</p> <p>This manual explains the dedicated instructions used to exercise PID control.</p> <p>(Optional)</p>	<p>SH-080040 (13JF59)</p>
<p>QCPU (Q Mode)/QnACPU Programming Manual (SFC)</p> <p>This manual explains the system configuration, performance specifications, functions, programming, debugging, error codes and others of MELSAP3.</p> <p>(Optional)</p>	<p>SH-080041 (13JF60)</p>
<p>I/O Module Type Building Block User's Manual</p> <p>This manual explains the specifications of the I/O modules, connector, connector/terminal block conversion modules and others.</p> <p>(Optional)</p>	<p>SH-080042 (13JL99)</p>

(3) Servo amplifier

Manual Name	Manual Number (Model Code)
SSCNETⅢ Compatible MR-J3-□B Servo amplifier Instruction Manual This manual explains the I/O signals, parts names, parameters, start-up procedure and others for MR-J3-□B Servo amplifier. <p style="text-align: right;">(Optional)</p>	SH-030051 (1CW202)
SSCNETⅢ Compatible Linear Servo MR-J3-□B-RJ004 Servo amplifier Instruction Manual This manual explains the I/O signals, parts names, parameters, start-up procedure and others for Linear Servo MR-J3-□B-RJ004 Servo amplifier. <p style="text-align: right;">(Optional)</p>	SH-030054 (1CW943)
SSCNETⅢ Compatible Fully Closed Loop Control MR-J3-□B-RJ006 Servo amplifier Instruction Manual This manual explains the I/O signals, parts names, parameters, start-up procedure and others for Fully Closed Loop Control MR-J3-□B-RJ006 Servo amplifier. <p style="text-align: right;">(Optional)</p>	SH-030056 (1CW304)

1. OVERVIEW

1.1 Overview

This User's Manual describes the hardware specifications and handling methods of the Motion Controller Q170MCPU for the Q series PLC Multiple CPU system.

The Manual also describes those items related to the specifications of the option module for the Motion controller, Manual pulse generator and cables.

In this manual, the following abbreviations are used.

Generic term/Abbreviation	Description
Q170MCPU or Motion controller	Q170MCPU Motion controller
Q172DLX/Q173DPX or Motion module	Q172DLX Servo external signals interface module/ Q173DPX Manual pulse generator interface module
MR-J3-□B	Servo amplifier model MR-J3-□B
AMP or Servo amplifier	General name for "Servo amplifier model MR-J3-□B"
Multiple CPU system or Motion system	Abbreviation for "Multiple PLC system of the Q series"
PLC CPU area	PLC control area (CPU No.1) of Q170MCPU Motion controller
Motion CPU area	Motion control area (CPU No.2) of Q170MCPU Motion controller
CPU _n	Abbreviation for "CPU No.n (n= 1 to 4) of the CPU module for the Multiple CPU system"
Operating system software	General name for "SW□DNC-SV□Q□"
SV13	Operating system software for conveyor assembly use (Motion SFC) : SW8DNC-SV13Q□
SV22	Operating system software for automatic machinery use (Motion SFC) : SW8DNC-SV22Q□
Programming software package	General name for MT Developer2/GX Developer/MR Configurator
MELSOFT MT Works2	Abbreviation for "Motion controller engineering environment MELSOFT MT Works2"
MT Developer2 ^(Note-1)	Abbreviation for "Motion controller programming software MT Developer2 (Version 1.05F or later)"
GX Developer	Abbreviation for "MELSEC PLC programming software package GX Developer (Version 8.74C or later)"
MR Configurator	Abbreviation for "Servo setup software package MR Configurator (Version C2 or later)"
Manual pulse generator or MR-HDP01	Abbreviation for "Manual pulse generator (MR-HDP01)"
SSCNET III ^(Note-2)	High speed synchronous network between Motion controller and servo amplifier
Absolute position system	General name for "system using the servomotor and servo amplifier for absolute position"
Intelligent function module	Abbreviation for "CC-Link IE module/CC-Link module/MELSECNET/10(H) module/Ethernet module/Serial communication module"

(Note-1) : This software is included in Motion controller engineering environment "MELSOFT MT Works2".

(Note-2) : SSCNET: Servo System Controller NETwork

1 OVERVIEW

REMARK

For information about the each module, design method for program and parameter, refer to the following manuals.

Item		Reference Manual
PLC CPU area, peripheral devices for PLC program design, I/O modules and intelligent function module		MELSEC-Q series PLC Manuals, Manual relevant to each module
Operation method for MT Developer2		Help of each software
SV13/SV22	<ul style="list-style-type: none"> • Multiple CPU system configuration • Performance specification • Design method for common parameter • Auxiliary and applied functions (common) 	Q173DCPU/Q172DCPU Motion controller Programming Manual (COMMON)
SV13/SV22	<ul style="list-style-type: none"> • Design method for Motion SFC program • Design method for Motion SFC parameter • Motion dedicated PLC instruction 	Q173DCPU/Q172DCPU Motion controller (SV13/SV22) Programming Manual (Motion SFC)
	<ul style="list-style-type: none"> • Design method for positioning control program in the real mode • Design method for positioning control parameter 	Q173DCPU/Q172DCPU Motion controller (SV13/SV22) Programming Manual (REAL MODE)
SV22 (Virtual mode)	<ul style="list-style-type: none"> • Design method for mechanical system program 	Q173DCPU/Q172DCPU Motion controller (SV22) Programming Manual (VIRTUAL MODE)

1 OVERVIEW

1.2 Comparison between Q170MCPUCPU and Q173DCPU/Q172DCPU

(1) Comparison of hardware

Item		Q170MCPUCPU	Q173DCPU	Q172DCPU
Power supply		Built-in (24VDC)	Power supply module (24VDC, 100VAC, 200VAC)	
PLC CPU area		Q03UDCPU or equivalent (20k steps)	QnUD(E)(H)CPU	
Program capacity		20k steps	30k to 260k steps	
LD instruction processing speed		0.02μs	0.0095 to 0.02μs	
Motion CPU area		Q172DCPU or equivalent (16 axes)	Q173DCPU	Q172DCPU
Forced stop input		Use forced stop input terminal		
Base unit	Main base unit	None	Multiple CPU high speed main base unit (Q38B/Q312DB)	
	Extension base unit	1 extension (Q52B/Q55B usable)	7 extensions	
	GOT bus connection	<ul style="list-style-type: none"> Extension base unit use: Connection after the extension base unit of stage 1 Extension base unit not use: Direct bus connection to Motion controller 	Bus connection on main base unit or extension base unit	
Motion module	Q172DLX	2 modules	4 modules	1 module
	Q172DEX	Unusable	6 modules	4 modules
	Q173DPX ^(Note-1)	3 modules	4 modules	3 modules
	Base unit for installation	Extension base unit	Main base unit, Extension base unit (Impossible to install on I/O slots of 0 to 2 main base unit)	
Battery		Demand		
Q6BAT		Packed together with Motion controller		
Q7BAT (Large capacity)		Usable (sold separately)	Unusable	
Multiple CPU system	Number of CPUs	2 modules	2 to 4 modules	
	CPU No.1	PLC CPU area	PLC CPU module, C controller module	
	CPU No.2	Motion CPU area	PLC CPU module, Motion CPU module, C controller module	
	CPU No.3	—		
	CPU No.4	—		
Mounting method		Be sure to mount Motion controller on control panel by fixing screws	Be sure to install Motion CPU modules on main base unit by fixing screws	
Exterior dimensions [mm(inch)]		178 (7.01)(H) × 52 (2.05)(W) × 135 (5.31)(D)	98 (3.85)(H) × 27.4 (1.08)(W) × 119.3 (4.69)(D)	
Medium of operating system software		CD-ROM (1 disk)		
Model of operating system software	SV13	SW8DNC-SV13QG	SW8DNC-SV13QB	SW8DNC-SV13QD
	SV22	SW8DNC-SV22QF	SW8DNC-SV22QA	SW8DNC-SV22QC
	SV43	—	SW7DNC-SV43QA	SW7DNC-SV43QC
Programming tool	PLC CPU area	GX Developer		
	Motion CPU area	MT Developer2		

(Note-1): When using the incremental synchronous encoder (SV22 use), you can use above number of modules.
When connecting the manual pulse generator, you can use only 1 module.

1 OVERVIEW

(2) Comparison of Motion control specifications

Item		Q170MCPUCPU	Q173DCPU	Q172DCPU
Number of control axes		Up to 16 axes	Up to 32 axes	Up to 8 axes
Operation cycle (default)	SV13	0.44ms/ 1 to 6 axes 0.88ms/ 7 to 16 axes	0.44ms/ 1 to 6 axes 0.88ms/ 7 to 18 axes 1.77ms/19 to 32 axes	0.44ms/ 1 to 6 axes 0.88ms/ 7 to 8 axes
	SV22	0.44ms/ 1 to 4 axes 0.88ms/ 5 to 12 axes 1.77ms/13 to 16 axes	0.44ms/ 1 to 4 axes 0.88ms/ 5 to 12 axes 1.77ms/13 to 28 axes	0.44ms/ 1 to 4 axes 0.88ms/ 5 to 8 axes
	SV43	—	3.55ms/29 to 32 axes	
Interpolation functions		Linear interpolation (Up to 4 axes), Circular interpolation (2 axes), Helical interpolation (3 axes)		
Control modes		PTP(Point to Point) control, Speed control, Fixed-pitch feed, Constant speed control, Position follow-up control, Speed control with fixed position stop, Speed switching control, High-speed oscillation control, Synchronous control (SV22)		
		Speed-position control (External input signal (DOG) of servo amplifier usable)	Speed-position control	
Acceleration/deceleration control		Automatic trapezoidal acceleration/deceleration, S-curve acceleration/deceleration		
Compensation		Backlash compensation, Electronic gear, Phase compensation (SV22)		
Programming language		Motion SFC, Dedicated instruction, Mechanical support language (SV22)		
Servo program capacity		16k steps		
Number of positioning points		3200 points (Positioning data can be designated indirectly)		
Peripheral I/F	USB/RS-232	PLC CPU area control	PLC CPU module control	
	PERIPHERAL I/F	Motion CPU area control	None	
Home position return function		Proximity dog type (2 types), Data set type (2 types), Dog cradle type, Stopper type (2 types), Limit switch combined type		
		Count type (3 types) (External input signal (DOG) of servo amplifier usable)	Count type (3 types)	
		Home position return re-try function provided, home position shift function provided		
JOG operation function		Provided		
Manual pulse generator operation function		Possible to connect 3 modules		
Synchronous encoder operation function		Possible to connect 8 modules (SV22 use), ABS synchronous encoder unusable	Possible to connect 12 modules (SV22 use)	Possible to connect 8 modules (SV22 use)
M-code function		M-code output function provided M-code completion wait function provided		
Limit switch output function		Number of output points 32 points Watch data: Motion control data/Word device		
ROM operation function		Provided		
Absolute position system		Made compatible by setting battery to servo amplifier. (Possible to select the absolute data method or incremental method for each axis)		
External input signal		Q172DLX or External input signals (FLS/RLS/DOG) of servo amplifier		
Number of SSCNETⅢ systems (Note-1)		1 system	2 systems	1 system
High-speed reading function		Via I/O module, Via tracking of Q173DPX		
Forced stop		EMI terminal of Motion controller, Forced stop input setting in the system setting, Forced stop signal (EM1) of the servo amplifier		
Clock data setting		Clock synchronization between Multiple CPU		
PLC module which can be control by Motion CPU (area)		Interrupt module, Input module, Output module, Input/Output composite module, Analogue input module, Analogue output module		

(Note-1) : The servo amplifiers for SSCNET cannot be used.

1 OVERVIEW

(3) Comparison of Motion SFC performance specifications

Item		Q170MCPU	Q173DCPU/Q172DCPU		
Motion SFC program capacity	Code total (Motion SFC chart + Operation control + Transition)	543k bytes			
	Text total (Operation control + Transition)	484k bytes			
Motion SFC program	Number of Motion SFC programs	256 (No.0 to 255)			
	Motion SFC chart size/program	Up to 64k bytes (Included Motion SFC chart comments)			
	Number of Motion SFC steps/program	Up to 4094 steps			
	Number of selective branches/branch	255			
	Number of parallel branches/branch	255			
	Parallel branch nesting	Up to 4 levels			
Operation control program (F/FS) / Transition program (G)	Number of operation control programs	4096 with F(Once execution type) and FS(Scan execution type) combined. (F/FS0 to F/FS4095)			
	Number of transition programs	4096(G0 to G4095)			
	Code size/program	Up to approx. 64k bytes (32766 steps)			
	Number of blocks(line)/program	Up to 8192 blocks (in the case of 4 steps(min)/blocks)			
	Number of characters/block	Up to 128 (comment included)			
	Number of operand/block	Up to 64 (operand: constants, word device, bit devices)			
	() nesting/block	Up to 32 levels			
	Descriptive expression	Operation control program	Calculation expression/bit conditional expression		
Transition program		Calculation expression/bit conditional expression/ comparison conditional expression			
Execute specification	Number of multi execute programs	Up to 256			
	Number of multi active steps	Up to 256 steps/all programs			
	Executed task	Normal task	Execute in main cycle of Motion controller		
		Event task (Execution can be masked.)	Fixed cycle	Execute in fixed cycle (0.44ms, 0.88ms, 1.77ms, 3.55ms, 7.11ms, 14.2ms)	Execute in fixed cycle (0.88ms, 1.77ms, 3.55ms, 7.11ms, 14.2ms)
			External interrupt	Execute when input ON is set among interrupt module QI60 (16 points).	
			PLC interrupt	Execute with interrupt instruction (D(P).GINT) from PLC.	
NMI task	Execute when input ON is set among interrupt module QI60 (16 points).				
Number of I/O points (X/Y)		8192 points			
Number of real I/O points (PX/PY)		256 points			
Number of devices (Device In the Motion CPU (area) only) (Included the positioning dedicated device)	Internal relays (M)	12288 points			
	Link relays (B)	8192 points			
	Annunciators (F)	2048 points			
	Special relays (SM)	2256 points			
	Data registers (D)	8192 points			
	Link registers (W)	8192 points			
	Special registers (SD)	2256 points			
	Motion registers (#)	12288 points			
	Coasting timers (FT)	1 point (888μs)			
	Multiple CPU area devices (U□\G)	Up to 14336 points usable ^(Note)			

(Note): Usable number of points changes according to the system settings.

1 OVERVIEW

(4) Comparison of Mechanical system program specifications

Item		Q170MCPU	Q173DCPU	Q172DCPU				
Control units	Drive module	Virtual servomotor	PLS					
		Synchronous encoder	PLS					
	Output module	Roller	mm, inch					
		Ball screw	mm, inch					
		Rotary table	degree					
Cam	mm, inch, PLS							
Program language		Dedicated instructions (Servo program + mechanical system program)						
Number of modules which can be set per CPU	Drive module	Virtual servomotor	16	Total 24	32	Total 44	8	Total 16
		Synchronous encoder	8		32		8	
	Virtual axis	Virtual main shaft	16	Total 32	32	Total 64	8	Total 16
		Virtual auxiliary input axis	16		32		8	
	Transmission module	Gear	32		64		16	
		Direct clutch	32		64		16	
		Smoothing clutch	32		64		16	
		Speed change gear	32		64		16	
		Differential gear	16		32		8	
	Differential gear to main shaft	16		32		8		
	Output module	Roller	16	Total 16	32	Total 32	8	Total 8
		Ball screw	16		32		8	
		Rotary table	16		32		8	
		Cam	16		32		8	
	Cam	Types	Up to 256 ^(Note-1)					
		Resolution per cycle	256 • 512 • 1024 • 2048 ^(Note-1)					
Memory capacity		132k bytes						
Storage memory for cam data		CPU internal RAM memory						
Stroke resolution		32767						
Control mode		Two-way cam/feed cam						

(Note-1): Relation between a resolution per cycle of cam and type are shown below.

Resolution per cycle	256	512	1024	2048
Type	256	128	64	32

1 OVERVIEW

(5) Comparison of PLC CPU area control and performance

Item		Q170MCP	Q173DCPU/Q172DCPU
PLC CPU area		Q03UDCPU or equivalent (20k steps)	QnUD(E)(H)CPU
Control method		Sequence program control method	
I/O control mode		Refresh mode	
Sequence control language		Relay symbol language (ladder), logic symbolic language (list), MELSAP3 (SFC), MELSAP-L, Structured text (ST)	
Processing speed (sequence instruction)	LD instruction	0.02 μ s	0.0095 to 0.02 μ s
	MOV instruction	0.04 μ s	0.019 to 0.04 μ s
	PC MIX value (instruction/ μ s)	28	28 to 60
	Floating point addition	0.12 μ s	0.057 to 0.12 μ s
Total number of instructions		858	
Operation (floating point operation) instruction		Yes	
Character string processing instruction		Yes	
PID instruction		Yes	
Special function instruction (Trigonometric function, square root, exponential operation, etc.)		Yes	
Constant scan		0.5 to 2000ms (Setting available in 0.5ms unit.)	
Program capacity		20k steps	30k to 260k steps
CPU shared memory	QCPU standard memory	8k bytes	
	Multiple CPU high speed transmission area	32k bytes	
No. of I/O device points (X/Y)		8192 points	
No. of I/O points (X/Y)		512 points	4096 points
Internal relay (M)	Points by default (changeable by parameters)	8192 points	
Latch relay (L)		8192 points	
Link relay (B)		8192 points	
Timer (T)		2048 points	
Retentive timer (ST)		0 points	
Counter (C)		1024 points	
Data register (D)		12288 points	
Link register (W)		8192 points	
Annunciator (F)		2048 points	
Edge relay (V)		2048 points	
Link special relay (SB)		2048 points	
Link special register (SW)		2048 points	
File register (R, ZR)		98304 points	98304 to 655360 points
Step relay (S)	8192 points		
Index register/Standard devise register (Z)	20 points		
Index register (Z) (32-bit modification specification of ZR device)	Up to 10 points (Z0 to Z18) (Index register (Z) is used in double words.)		
Pointer (P)	4096 points		
Interrupt pointer (I)	256 points		
Special relay (SM)	2048 points		
Special register (SD)	2048 points		
Function input (FX)	16 points		
Function output (FY)	16 points		
Function register (FD)	5 points		
Local device	Yes		
Device initial values	Yes		

1 OVERVIEW

Comparison of PLC CPU area control and performance (Continued)

Item		Q170MCP	Q173DCPU/Q172DCPU
Extension base unit	Number of extension	1 extension (Q52B/Q55B usable)	7 extensions
	GOT bus connection	<ul style="list-style-type: none"> • Extension base unit use: Connection after the extension base unit of stage 1 • Extension base unit not use: Direct bus connection to Motion controller 	Bus connection on main base unit or extension base unit
PC type when program is made by GX Developer		Q03UDCPU	QnUD(E)(H)CPU

2. SYSTEM CONFIGURATION

This section describes the Motion controller (Q170MCPU) system configuration, precautions on use of system and configured equipments.

2.1 Motion System Configuration

(1) Equipment configuration in Q170MCPU system

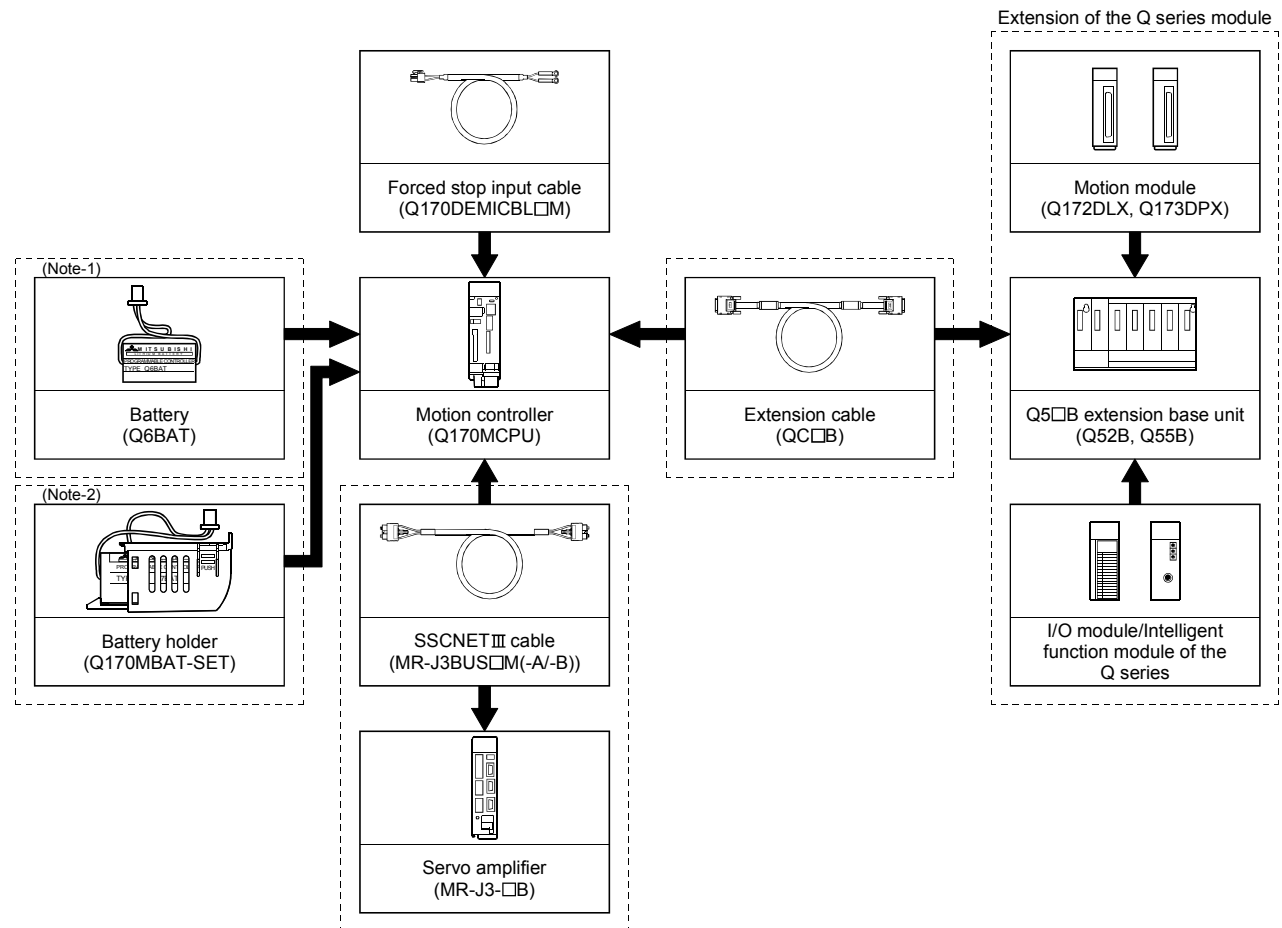

It is possible to select the best according to the system.

(Note-1): Be sure to install the Battery (Q6BAT) to the Battery holder.
(It is packed together with Q170MCPU.)

(Note-2): Large capacity battery use (Q7BAT is included), sold separately.

(2) Peripheral device configuration for the Q170MCP

The following (a)(b)(c) can be used.

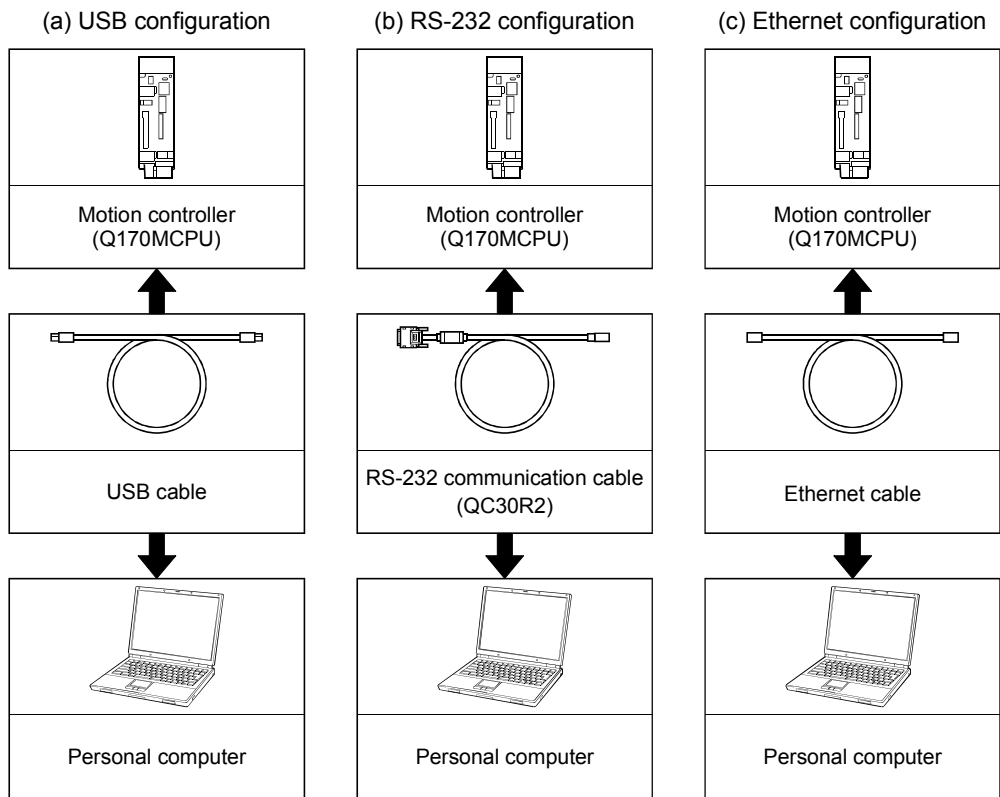

2 SYSTEM CONFIGURATION

2.1.1 Q170MCPU System overall configuration

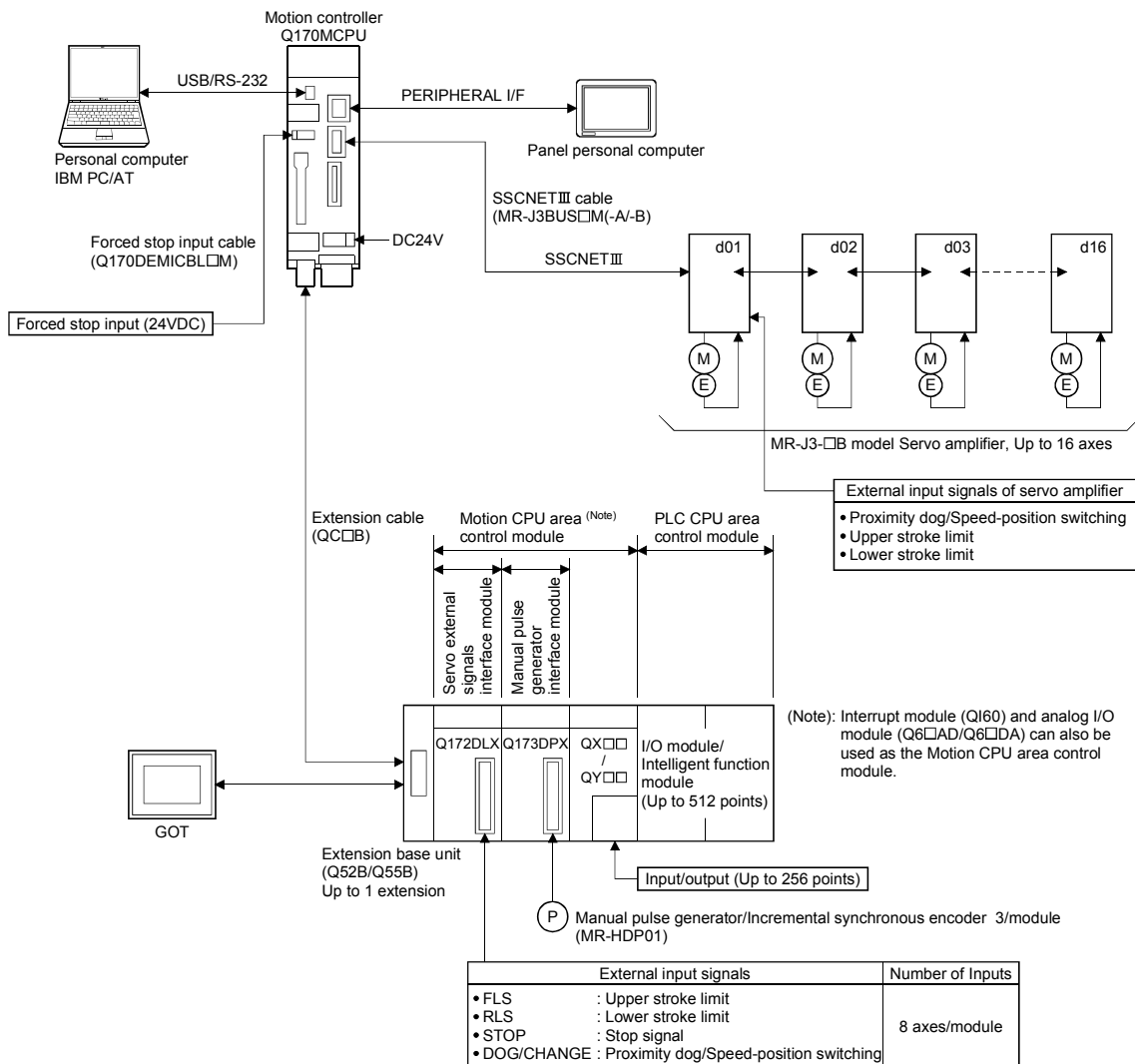

⚠ CAUTION

- Construct a safety circuit externally of the Motion controller or servo amplifier if the abnormal operation of the Motion controller or servo amplifier differ from the safety directive operation in the system.
- The ratings and characteristics of the parts (other than Motion controller, servo amplifier and servomotor) used in a system must be compatible with the Motion controller, servo amplifier and servomotor.
- Set the parameter values to those that are compatible with the Motion controller, servo amplifier, servomotor and regenerative resistor model and the system application. The protective functions may not function if the settings are incorrect.

2 SYSTEM CONFIGURATION

2.1.2 Q170MCPU System internal configuration

(1) What is Multiple CPU system for Q170MCPU ?

A Multiple CPU system for Q170MCPU is a system in which between the PLC CPU area and Motion CPU area are connected with the Multiple CPU high speed bus in order to control the I/O modules and intelligent function modules.

PLC CPU area is fixed as CPU No.1, and Motion CPU area is fixed as CPU No.2.

And, the Motion CPU area controls the servo amplifiers connected by SSCNET III cable.

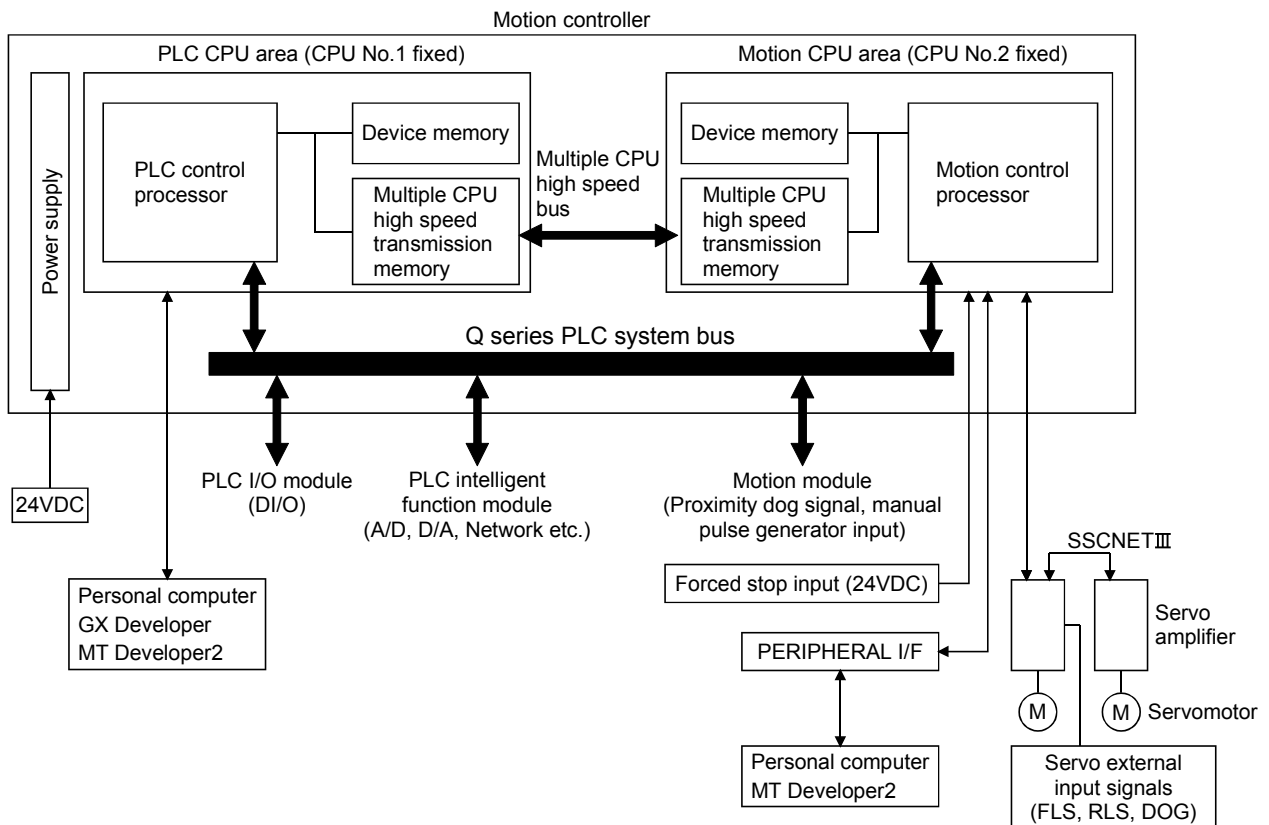

- The device memory is the memory area for the bit devices (X, Y, M, etc.) and word devices (D, W, etc.).
- The Multiple CPU high speed transmission memory between the PLC CPU area and Motion CPU area can be communicated at 0.88ms cycles.

2.1.3 Function explanation of the Q170MCPU Motion controller

(1) Whole

- (a) The Multiple CPU high speed bus is equipped with between the PLC CPU area and Motion CPU area. With this reserved Multiple CPU high speed bus, data transfer of 0.88ms period is possible for up to 14k words.
- (b) Data transfer between the PLC CPU area and Motion CPU area is possible by Multiple CPU high speed transmission memory or automatic refresh.
- (c) The Multiple CPU high speed transmission cycle is synchronized with the motion control cycle thus optimizing the control system.

(2) PLC CPU area

- (a) The I/O modules, analog I/O modules, pulse I/O modules, positioning modules, information modules and network can be controlled with the sequence program.
- (b) The device data access and program start of the Motion CPU area can be executed by the Motion dedicated PLC instructions.
- (c) The real-time processing can be realized by the Multiple CPU synchronous interrupt program.

(3) Motion CPU area

- (a) Up to 16 axes servo amplifiers per 1 system can be controlled in Q170MCPU.
- (b) It is possible to set the program which synchronized with the motion operation cycle and executed at fixed cycle (0.44[ms], 0.88[ms], 1.77[ms], 3.55[ms], 7.11[ms], 14.2[ms]).
- (c) It is possible to execute a download of servo parameters to servo amplifier, servo ON/OFF to servo amplifier and position commands, etc. by connecting between the Q170MCPU and servo amplifier with SSCNETIII cable.
- (d) It is possible to select the servo control functions/programming languages by installing the corresponding operating system software in the Q170MCPU.
- (e) Motion modules (Q172DLX/Q173DPX) are controlled with the Motion CPU area, and the signals such as stroke limit signals connected to Motion modules and incremental synchronous encoder can be used as motion control.
- (f) The synchronous control can be executed by using the incremental synchronous encoder (up to 8 axes).
- (g) The stroke limit signals and proximity dog signals connected to the servo amplifiers can be used for the motion control.
- (h) PLC I/O modules can be controlled with the Motion CPU area.
(Refer to Section 2.3(2).)
- (i) Wiring is reduced by issuing the external signal (upper/lower stroke limit signal, proximity dog signal) via the servo amplifier.

2 SYSTEM CONFIGURATION

2.1.4 Restrictions on Motion controller

- (1) Only extension base unit (Q52B/Q55B) of type not requiring power supply module can be used.
- (2) Q170MCPU Multiple CPU system is composed of the PLC CPU area (CPU No.1 fixed) and Motion CPU area (CPU No.2 fixed). Other CPU (CPU No.3, CPU No.4) cannot be set.
- (3) It takes about 10 seconds to startup (state that can be controlled) of Motion controller. Make a Multiple CPU synchronous startup setting suitable for the system.
- (4) Execute the automatic refresh of the Motion CPU area and PLC CPU area by using the automatic refresh of Multiple CPU high speed transmission area setting.
- (5) The Motion modules, I/O modules and intelligent function modules, etc. can be installed on the extension base unit only.
- (6) The CPU modules cannot be installed on the extension base unit.
- (7) When using the GOT with bus connection, connect the GOT after the extension base unit of stage 1 in the case with the extension base use, and connect directly to the Motion controller in the case with the extension base unused.
- (8) The synchronous encoder interface module Q172DEX/Q172EX(-S1/-S2/-S3) cannot be used.
- (9) Be sure to control the Motion modules (Q172DLX, Q173DPX) with the Motion CPU area. They will not operate correctly if PLC CPU area is set by mistake.
- (10) Q172LX/Q173PX(-S1) for Q173HCPU(-T)/ Q172HCPU(-T)/Q173CPUN(-T)/ Q172CPUN(-T)/Q173CPU/Q172CPU cannot be used.
- (11) Motion CPU area cannot be set as the control CPU of intelligent function module (except some modules) or Graphic Operation Terminal(GOT).
- (12) Be sure to set the battery.
- (13) There are following methods to execute the forced stop input.
 - Use a EMI terminal of Q170MCPU.
 - Use a device set in the forced stop input setting of system setting
- (14) Forced stop input for EMI terminal of Q170MCPU cannot be invalidated by the parameter.
When the device set in the forced stop input setting is used without use of EMI terminal of Q170MCPU, apply 24VDC voltage on EMI terminal and invalidate the forced stop input of EMI terminal.

2 SYSTEM CONFIGURATION

- (15) Be sure to use the cable for forced stop input. The forced stop cannot be released without using it. Fabricate the cable for forced stop input on the customer side or purchase our products (sold separately).
- (16) When the operation cycle is 0.4[ms], set the system setting as the axis select switch of servo amplifier "0 to 7".
If the axis select switch of servo amplifier "8 to F" is set, the servo amplifiers are not recognized.
- (17) When the extension base units are used, make sure to configure the modules so that the total current consumption of the Q170MCPU and individual modules on the extension base do not exceed the 5VDC output capacity of Q170MCPU power supply.
- (18) The module name displayed by "System monitor" - "Product information list" of GX Developer is different depending on the function version of Motion modules (Q172DLX, Q173DPX).
(Note): Even if the function version "C" is displayed, it does not correspond to the online module change.

Module name	Model display	
	Function version "B"	Function version "C"
Q172DLX	Q172LX	Q172DLX
Q173DPX	MOTION-UNIT	Q173DPX

2 SYSTEM CONFIGURATION

2.2 Checking Serial Number and Operating System Software Version

Checking for the serial number of Motion controller and Motion module, and the operating system software version are shown below.

2.2.1 Checking serial number

(1) Motion controller (Q170MCPU)

(a) Rating plate

The rating plate is situated on the side face of the Motion controller.

(b) Front of Motion controller

The serial number is printed in the projection parts forward of the lower side of Motion controller.

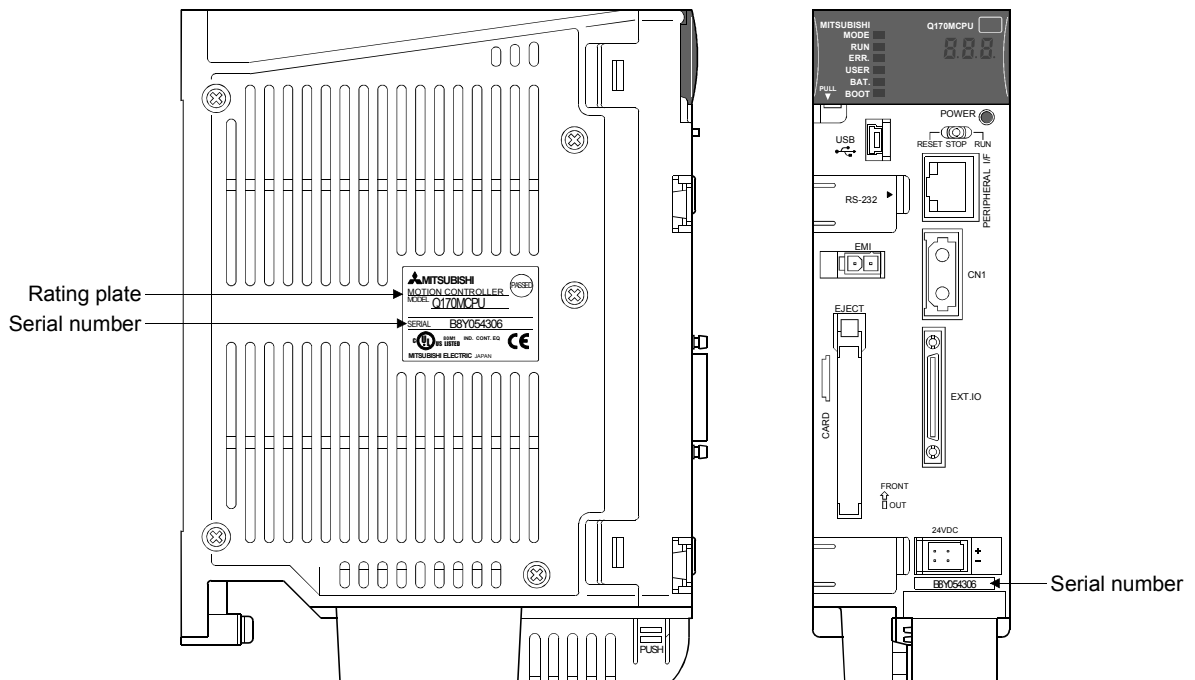

(c) System monitor (product information list)

The serial number can be checked on the system monitor screen in GX Developer. (Refer to Section 2.2.2.)

2 SYSTEM CONFIGURATION

(2) Motion module (Q172DLX/Q173DPX)

(a) Rating plate

The rating plate is situated on the side face of the Motion module.

(b) Front of Motion module

The serial No. is printed in the projection parts forward of the lower side of Motion module.

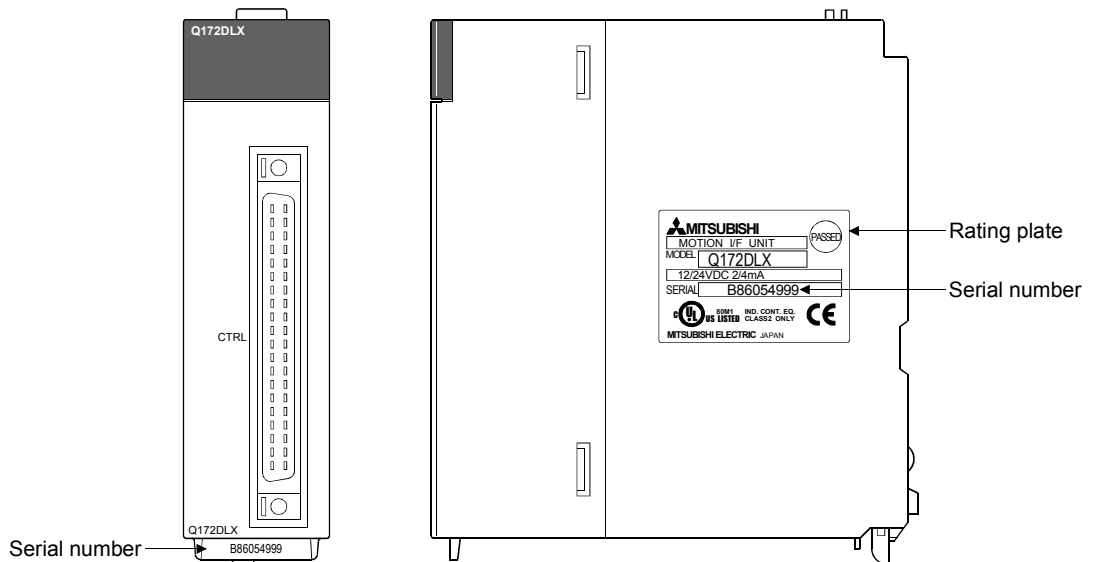

REMARK

The serial number display was corresponded from the Motion modules manufactured in early April 2008.

2 SYSTEM CONFIGURATION

2.2.2 Checking operating system software version

The operating system software version can be checked on the system monitor screen in GX Developer.

Select [Product Inf. List] button on the system monitor screen displayed on [Diagnostics] – [System monitor] of GX Developer.

The screenshot shows the 'System Monitor' window with the following sections:

- Installed status:** A table showing the Master PLC and various modules (Q170MCP, U-PCPU, and 8 Unmo units).
- Parameter status:** A table showing I/O addresses and parameters for the Master PLC and modules.
- Base:** Radio buttons for 'Main base' and 'Extension base 1' through '7'.
- Mode:** Radio buttons for 'System monitor' and 'Online module change'.
- Buttons:** 'Diagnostics...', 'Module's Detailed Information...', 'Base Information...', 'Product Inf. List...', 'Detailed inf. of power supply...', and 'Close'.
- Status:** Checkboxes for 'Module system error', 'Module error', and 'Module warning', along with 'Start monitor' and 'Stop monitor' buttons.

The 'Product Information List' window displays the following table:

Slot	Type	Series	Model name	Points	I/O No.	Master PLC	Serial No	Ver.	Product No.
PLC	PLC	Q	Q170MCPU-SCPU	-	-	-	01110000000000	B	-
0-0	PLC	Q	Q170MCPU-PCPU	-	-	-	SV22f VER300G	B	B8Y054306-
0-1	-	-	None	-	-	-	-	-	-
0-2	-	-	None	-	-	-	-	-	-
0-3	-	-	None	-	-	-	-	-	-
0-4	-	-	None	-	-	-	-	-	-
0-5	-	-	None	-	-	-	-	-	-
0-6	-	-	None	-	-	-	-	-	-
0-7	-	-	None	-	-	-	-	-	-

2 SYSTEM CONFIGURATION

2.3 System Configuration Equipment

(1) Motion controller related module

Part name	Model name ^(Note-1)	Description	Current consumption 5VDC[A]	Remark
Motion controller	Q170MCPU	Power supply, PLC CPU, Motion CPU, all-in-one type (Attachment battery (Q6BAT), external I/O connector, 24VDC power supply connector and connector for forced stop input cable) • Motion CPU area Up to 16 axes control, Operation cycle 0.44[ms] or more, Servo program capacity 16k steps • PLC CPU area Program capacity 20k steps, LD instruction processing speed 0.02μs	2.0	
Servo external signals interface module	Q172DLX	Servo external signal input 8 axes (FLS, RLS, STOP, DOG/CHANGE×8)	0.06	
Manual pulse generator interface module	Q173DPX	Manual pulse generator MR-HDP01/Incremental synchronous encoder interface ×3, Tracking input 3 points	0.38	
Manual pulse generator	MR-HDP01	Pulse resolution: 25PLS/rev(100PLS/rev after magnification by 4) Permitted axial loads Radial load: Up to 19.6N Thrust load: Up to 9.8N Permitted speed: 200r/min(Normal rotation), Voltage-output	0.06	
Battery	Q6BAT	For memory data backup of RAM built-in Motion controller	—	
Large capacity battery	Q7BAT			
Large capacity battery holder	Q170BAT-SET	Battery holder for Q7BAT (Attachment Q7BAT)	—	
Cable for forced stop input ^(Note-2)	Q170DEMICBL□M	Length 0.5m(1.64ft), 1m(3.28ft), 3m(9.84ft), 5m(16.40ft), 10m(32.81ft), 15m(49.21ft), 20m(65.62ft), 25m(82.02ft), 30m(98.43ft)	—	
Connector for forced stop input cable	Q170DEMICON	Connector for forced stop input cable production	—	
Extension base unit ^(Note-3)	Q52B	Number of I/O modules installed 2 slots, type not requiring power supply module	0.08	
	Q55B	Number of I/O modules installed 5 slots, type not requiring power supply module	0.10	
Extension cable	QC05B	Length 0.45m(1.48ft.)	—	
	QC06B	Length 0.6m(1.97ft.)		
	QC12B	Length 1.2m(3.94ft.)		
	QC30B	Length 3m(9.84ft.)		
	QC50B	Length 5m(16.40ft.)		
	QC100B	Length 10m(32.81ft.)		

2 SYSTEM CONFIGURATION

Motion controller related module(continued)

Part name	Model name ^(Note-1)	Description	Current consumption 5VDC[A]	Remark
SSCNET III cable	MR-J3BUS□M	<ul style="list-style-type: none"> • Q170MCPUR ↔ MR-J3-□B • MR-J3-□B ↔ MR-J3-□B • Standard cord for inside panel • 0.15m(0.49ft.), 0.3m(0.98ft.), 0.5m(1.64ft.), 1m(3.28ft.), 3m(9.84ft.) 	—	
	MR-J3BUS□M-A	<ul style="list-style-type: none"> • Q170MCPUR ↔ MR-J3-□B • MR-J3-□B ↔ MR-J3-□B • Standard cable for outside panel • 5m(16.40ft.), 10m(32.81ft.), 20m(65.62ft.) 	—	
	MR-J3BUS□M-B ^(Note-4)	<ul style="list-style-type: none"> • Q170MCPUR ↔ MR-J3-□B • MR-J3-□B ↔ MR-J3-□B • Long distance cable • 30m(98.43ft.), 40m(131.23ft.), 50m(164.04ft.) 	—	

(Note-1) : □=Cable length (015: 0.15m(0.49ft.), 03: 0.3m(0.98ft.), 05: 0.5m(1.64ft.), 1: 1m(3.28ft.), 2: 2m(6.56ft.), 3: 3m(9.84ft.), 5: 5m(16.40ft.), 10: 10m(32.81ft.), 20: 20m(65.62ft.), 25: 25m(82.02ft.), 30: 30m(98.43ft.), 40: 40m(131.23ft.), 50:50m(164.04ft.)

(Note-2) : Be sure to use the cable for forced stop input (sold separately). The forced stop cannot be released without using it.

Cable for forced stop input is not attached to the Motion controller. Please purchase the cable for length according to system separately.

(Note-3) : 5VDC internal current consumption of shared equipments with PLC might be changed.

Be sure to refer to the MELSEC-Q series PLC Manuals.

(Note-4) : Please contact your nearest Mitsubishi sales representative for the cable of less than 30m(98.43ft.).

2 SYSTEM CONFIGURATION

(2) PLC module which can be controlled by Motion CPU area

Part name		Model name	Description	Current consumption 5VDC[A] <small>(Note-1)</small>	Remark	
Input module	AC	QX10	100-120VAC, 7-8mA, 16 points, Terminal block	0.05 (TYP, All points ON)		
	DC	QX40	24VDC/4mA, Positive common, 16 points, Terminal block	0.05 (TYP, All points ON)		
		QX40-S1	High response type, 24VDC/6mA, Positive common, 16 points, Terminal block	0.06 (TYP, All points ON)		
		QX41	24VDC/4mA, Positive common, 32 points, Connector	0.075 (TYP, All points ON)	(Note-2)	
		QX41-S1	High response type, 24VDC/4mA, Positive common, 32 points, Connector	0.075 (TYP, All points ON)	(Note-2)	
		QX42	24VDC/4mA, Positive common, 64 points, Connector	0.09 (TYP, All points ON)	(Note-2)	
		QX42-S1	High response type, 24VDC/4mA, Positive common, 64 points, Connector	0.09 (TYP, All points ON)	(Note-2)	
		QX70	12VDC/5V, Positive common/Negative common shared, 16 points, Terminal block	0.055 (TYP, All points ON)		
		QX71	12VDC/5V, Positive common/Negative common shared, 32 points, Terminal block	0.07 (TYP, All points ON)		
		QX72	12VDC/5V, Positive common/Negative common shared, 64 points, Terminal block	0.085 (TYP, All points ON)		
		QX80	24VDC/4mA, Negative common, 16 points, Terminal block	0.05 (TYP, All points ON)		
		QX81	24VDC/4mA, Negative common, 32 points, Connector	0.075 (TYP, All points ON)	(Note-2)	
		QX82-S1	High response type, 24VDC/4mA, Negative common, 64 points, Connector	0.09 (TYP, All points ON)	(Note-2)	
		Output module	Contact output module	QY10	240VAC/24VDC, 2A/point, 8A/common, 16 points/common, Terminal block	0.43 (TYP, All points ON)
Transistor	Sink Type		QY40P	12V/24VDC, 0.1A/point, 1.6A/common, 16 points/common, Terminal block	0.065 (TYP, All points ON)	
			QY41P	12V/24VDC, 0.1A/point, 2A/common, 32 points/common, Connector	0.105 (TYP, All points ON)	(Note-2)
			QY42P	12V/24VDC, 0.1A/point, 2A/common, 64 points(32 points/common), Connector	0.15 (TYP, All points ON)	(Note-2)
			QY50	12V/24VDC, 0.5A/point, 4A/common, 16 points(16 points/common), Terminal block	0.08 (TYP, All points ON)	
	Source Type		QY80	12V/24VDC, 0.5A/point, 4A/common, 16 points(16 points/common), Terminal block	0.08 (TYP, All points ON)	
QY81P			12V/24VDC, 0.1A/point, 2A/common, 32 points(32 points/common), Connector	0.095 (TYP, All points ON)	(Note-2)	
TTL•CMOS (Sink)	QY70		5/12VDC, 16mA/point, 16 points(16 points/common), Terminal block	0.095 (TYP, All points ON)		
	QY71		5/12VDC, 16mA/point, 32 points(32 points/common), Connector	0.15 (TYP, All points ON)	(Note-2)	

2 SYSTEM CONFIGURATION

PLC module which can be controlled by Motion CPU area(continued)

Part name		Model name	Description	Current consumption 5VDC[A] ^(Note-1)	Remark
Input/Output composite module	DC Input/ Transistor output	QH42P	24VDC Positive common: 32 points 12-24VDC/0.1A Output Sink type: 32 points, Connector, Provided (Thermal protectors, protector against short circuit)	0.13 (TYP, All points ON)	(Note-2)
		QX48Y57	24VDC Positive common: 8 points 12-24VDC/0.5A Output Sink type: 7 points, Terminal block, Provided (When face is broken, LED lights and signal is output to CPU)	0.08 (TYP, All points ON)	
Interrupt module		QI60	24VDC/4mA, Positive common, 16 points, Terminal block	0.06 (TYP, All points ON)	
Analogue module		Q62AD-DGH	2ch, A/D conversion, Current input (Channel-isolated • High resolution)	0.33	
		Q64AD	4ch, A/D conversion, Voltage • Current input	0.63	
		Q64AD-GH	4ch, A/D conversion, Voltage • Current input (Channel-isolated • High resolution)	0.89	
		Q68ADV	8ch, A/D conversion, Voltage input	0.64	
		Q68ADI	8ch, A/D conversion, Current input	0.64	
		Q62DA	2ch, D/A conversion, Voltage • Current output	0.33	
		Q62DA-FG	2ch, D/A conversion, Voltage • Current output (Channel-isolated)	0.37	
		Q64DA	4ch, D/A conversion, Voltage • Current output	0.34	
		Q68DAV	8ch, D/A conversion, Voltage output	0.39	
		Q68DAI	8ch, D/A conversion, Current output	0.38	

(Note-1) : 5VDC internal current consumption of shared equipments with PLC might be changed.
Be sure to refer to the MELSEC-Q series PLC Manuals.

(Note-2) : Connectors are not provided.

(3) PLC module which can be controlled by PLC CPU area

They are the same modules as the PLC modules which can be controlled by the universal model QCPU "Q03UDCPU".

Refer to the MELSEC-Q series PLC Manuals.

(4) Servo amplifier

Part name	Model name	Description	Remarks
MR-J3 series servo amplifier	MR-J3-□B		Refer to catalogue of the servo amplifier.
	MR-J3-□B-RJ004	For linear servo motor	
	MR-J3-□B-RJ006	For fully closed control	
	MR-J3-□B-RJ080	For direct drive motor	
	MR-J3W-B	For 2-axis type	
Battery	MR-J3BAT	Back-up for the absolute position detection	

(5) Operating system software

Application	Software package
Conveyor assembly use SV13	SW8DNC-SV13QG
Automatic machinery use SV22	SW8DNC-SV22QF

2 SYSTEM CONFIGURATION

(6) Programming software packages

(a) Motion controller engineering environment

Part name	Model name
MELSOFT MT Works2 (MT Developer2 ^(Note-1))	SW1DNC-MTW2-E

(Note-1) : This software is included in Motion controller engineering environment "MELSOFT MT Works2".

(b) PLC software package

Model name	Software package
GX Developer	SW8D5C-GPPW-E

(c) Servo set up software package

Model name	Software package
MR Configurator	MRZJW3-SETUP221E

POINTS

When the operation of Windows[®] is not unclear in the operation of this software, refer to the manual of Windows[®] or guide-book from the other supplier.

(Note): Windows[®] is either registered trademarks or trademarks of Microsoft Corporation in the United States and/or other countries.

2 SYSTEM CONFIGURATION

2.4 General Specifications

General specifications of the Motion controller are shown below.

Item	Specification				
Operating ambient temperature	0 to 55°C (32 to 131°F)				
Storage ambient temperature	-25 to 75°C (-13 to 167°F) (Note-3)				
Operating ambient humidity	5 to 95% RH, non-condensing				
Storage ambient humidity	5 to 95% RH, non-condensing				
Vibration resistance		Frequency	Acceleration	Amplitude	Sweep count
	Under intermittent vibration	5 to 9Hz	—	3.5mm (0.138inch)	10 times each in X, Y, Z directions (For 80 min.)
		9 to 150Hz	9.8m/s ²	—	
	Under continuous vibration	5 to 9Hz	—	1.75mm (0.069inch)	
9 to 150Hz		4.9m/s ²	—		
Shock resistance	147m/s ² , 3 times in each of 3 directions X, Y, Z				
Operating ambience	No corrosive gases				
Operating altitude	2000m(6561.68ft.) or less				
Mounting location	Inside control panel				
Overvoltage category (Note-1)	II or less				
Pollution level (Note-2)	2 or less				

(Note-1) : This indicates the section of the power supply to which the equipment is assumed to be connected between the public electrical power distribution network and the machinery within premises.

Category II applies to equipment for which electrical power is supplied from fixed facilities.

The surge voltage withstand level for up to the rated voltage of 300V is 2500V.

(Note-2) : This index indicates the degree to which conductive material is generated in terms of the environment in which the equipment is used.

Pollution level 2 is when only non-conductive pollution occurs. A temporary conductivity caused by condensing must be expected occasionally.

(Note-3) : Do not use or store the Motion controller under pressure higher than the atmospheric pressure of altitude 0m. Doing so can cause an operation failure.

CAUTION

- The Motion controller must be stored and used under the conditions listed in the table of specifications above.
- When not using the module for a long time, disconnect the power line from the Motion controller or servo amplifier.
- Place the Motion controller and servo amplifier in static electricity preventing vinyl bags and store.
- When storing for a long time, please contact with our sales representative.
Also, execute a trial operation.

2 SYSTEM CONFIGURATION

2.5 Specifications of Equipment

2.5.1 Q170MCPU Motion controller

This section explains the specification of the Motion controller.

(1) Basic specifications of Q170MCPU

Item		Specification
24VDC power supply	Input voltage (Note-1), (Note-2)	21.6 to 26.4VDC (24VDC +/-10%, ripple ratio 5% or less)
	Inrush current (Note-3)	100A 1ms or less (at 24VDC input)
	Max. input current	1.36A
5VDC internal power supply	Max. supplied current	4.0A (Included Q170MCPU current consumption)
	Q170MCPU current consumption	2.0A
Efficiency		80% (TYP)
Input method		Connector
Allowable momentary power failure immunity (Note-4), (Note-5), (Note-6)		10ms (at 24VDC input)
Mass [kg]		0.9
Exterior dimensions [mm(inch)]		178 (7.01)(H) × 52 (2.05)(W) × 135 (5.31)(D)

POINTS

(Note-1) : Input power supply

Q170MCPU is rated for use with a 24VDC input power only. The Q170MCPU breaks down when 28VDC or more input.

(Note-2) : Select 24VDC power supply and electric wire within the range of 21.6 to 26.4VDC including any input ripple or spike voltage measured at the input connector of the Q170MCPU.

(Note-3) : Inrush current

Take care that the inrush current of several amperes may flow when the sharp square voltage is applied, or the power supply is turned ON with the mechanical switch.

When selecting a fuse and breaker in the external circuit, take account of the blow out, detection characteristics and above matters.

(Note-4) : Allowable momentary power failure period

(1) An instantaneous power failure lasting less than 10ms^(Note) will cause 24VDC down to be detected, but operation will continue.

(2) An instantaneous power failure lasting in excess of 10ms^(Note) may cause the operation to continue or initial start to take place depending on the power supply load.

(Note) : This is for a 24VDC input. This is 10ms or less for less than 24VDC.

(Note-5) : Select 24VDC power supply with allowable momentary power failure period of 20ms or more.

2 SYSTEM CONFIGURATION

(2) Motion control specifications/performance specifications

(a) Motion control specifications

Item	Specification
Number of control axes	Up to 16 axes
Operation cycle (default)	SV13 0.44ms/ 1 to 6 axes 0.88ms/ 7 to 16 axes
	SV22 0.44ms/ 1 to 4 axes 0.88ms/ 5 to 12 axes 1.77ms/13 to 16 axes
Interpolation functions	Linear interpolation (Up to 4 axes), Circular interpolation (2 axes), Helical interpolation (3 axes)
Control modes	PTP (Point to Point) control, Speed control, Speed-position control (External input signal (DOG) of servo amplifier usable), Fixed-pitch feed, Constant speed control, Position follow-up control, Speed control with fixed position stop, Speed switching control, High-speed oscillation control, Synchronous control (SV22)
Acceleration/ deceleration control	Automatic trapezoidal acceleration/deceleration, S-curve acceleration/deceleration
Compensation	Backlash compensation, Electronic gear, Phase compensation (SV22)
Programming language	Motion SFC, Dedicated instruction, Mechanical support language (SV22)
Servo program capacity	16k steps
Number of positioning points	3200 points (Positioning data can be designated indirectly)
Peripheral I/F	USB/RS-232 (PLC CPU area), PERIPHERAL I/F (Motion CPU area)
Home position return function	Proximity dog type (2 types), Count type (3 types, External input signal (DOG) of servo amplifier usable), Data set type (2 types), Dog cradle type, Stopper type (2 types), Limit switch combined type ----- Home position return re-try function provided, home position shift function provided
JOG operation function	Provided
Manual pulse generator operation function	Possible to connect 3 modules
Synchronous encoder operation function	Possible to connect 8 modules (SV22 use, Incremental only)
M-code function	M-code output function provided M-code completion wait function provided
Limit switch output function	Number of output points 32 points Watch data: Motion control data/Word device
ROM operation function	Provided
External input signal	Q172DLX, External input signal (FLS/RLS/DOG) of servo amplifier
High-speed reading function	Provided (Via input module, Via tracking of Q173DPX)
Forced stop	Motion controller forced stop (EMI terminal, System setting), Forced stop terminal of servo amplifier
Number of I/O points	Total of real I/O point : 256 points
Clock function	Provided
Security function	Provided

2 SYSTEM CONFIGURATION

Motion control specifications (continued)

Item	Specification
All clear function	Provided
Remote operation	Remote RUN/STOP, Remote latch clear
Digital oscillation function	Provided
Absolute position system	Made compatible by setting battery to servo amplifier. (Possible to select the absolute data method or incremental method for each axis)
Number of SSCNET III systems ^(Note-1)	1 system
Motion related interface module	Q172DLX : 2 module usable Q173DPX : 3 modules usable ^(Note-2)

(Note-1) : The servo amplifiers for SSCNET cannot be used.

(Note-2) : When using the incremental synchronous encoder (SV22 use), you can use above number of modules.
When connecting the manual pulse generator, you can use only 1 module.

2 SYSTEM CONFIGURATION

(b) Motion SFC performance specifications

Item		Specification		
Motion SFC program capacity	Code total (Motion SFC chart + Operation control + Transition)	543k bytes		
	Text total (Operation control + Transition)	484k bytes		
Motion SFC program	Number of Motion SFC programs	256 (No.0 to 255)		
	Motion SFC chart size/program	Up to 64k bytes (Included Motion SFC chart comments)		
	Number of Motion SFC steps/program	Up to 4094 steps		
	Number of selective branches/branch	255		
	Number of parallel branches/branch	255		
	Parallel branch nesting	Up to 4 levels		
Operation control program (F/FS) / Transition program (G)	Number of operation control programs	4096 with F(Once execution type) and FS(Scan execution type) combined. (F/FS0 to F/FS4095)		
	Number of transition programs	4096(G0 to G4095)		
	Code size/program	Up to approx. 64k bytes (32766 steps)		
	Number of blocks(line)/program	Up to 8192 blocks (in the case of 4 steps(min)/blocks)		
	Number of characters/block	Up to 128 (comment included)		
	Number of operand/block	Up to 64 (operand: constants, word device, bit devices)		
	() nesting/block	Up to 32 levels		
	Descriptive expression	Operation control program Transition program	Calculation expression/bit conditional expression Calculation expression/bit conditional expression/ comparison conditional expression	
Execute specification	Number of multi execute programs	Up to 256		
	Number of multi active steps	Up to 256 steps/all programs		
	Executed task	Normal task	Execute in main cycle of Motion controller	
		Event task (Execution can be masked.)	Fixed cycle	Execute in fixed cycle (0.44ms, 0.88ms, 1.77ms, 3.55ms, 7.11ms, 14.2ms)
			External interrupt	Execute when input ON is set among interrupt module QI60 (16 points).
			PLC interrupt	Execute with interrupt instruction (D(P).GINT) from PLC.
NMI task	Execute when input ON is set among interrupt module QI60 (16 points).			
Number of I/O points (X/Y)		8192 points		
Number of real I/O points (X/Y)		256 points		
Number of devices (Device In the Motion CPU area only) (Included the positioning dedicated device)	Internal relays (M)	12288 points		
	Link relays (B)	8192 points		
	Annunciators (F)	2048 points		
	Special relays (SM)	2256 points		
	Data registers (D)	8192 points		
	Link registers (W)	8192 points		
	Special registers (SD)	2256 points		
	Motion registers (#)	12288 points		
	Coasting timers (FT)	1 point (888µs)		
	Multiple CPU area devices (U□\G)	Up to 14336 points ^(Note)		

(Note): Usable number of points differs according to the system settings.

2 SYSTEM CONFIGURATION

(3) PLC control specifications

Item		Specification
PLC CPU area		Program capacity, number of I/O points and number of extensions were limited to Q03UDCPU
Control method		Sequence program control method
I/O control mode		Refresh mode
Sequence control language		Relay symbol language (ladder), logic symbolic language (list), MELSAP3 (SFC), MELSAP-L, Structured text (ST)
Processing speed (sequence instruction)	LD instruction	0.02 μ s
	MOV instruction	0.04 μ s
	PC MIX value (instruction/ μ s)	28
	Floating point addition	0.12 μ s
Total number of instructions		858
Operation (floating point operation) instruction		Yes
Character string processing instruction		Yes
PID instruction		Yes
Special function instruction (Trigonometric function, square root, exponential operation, etc.)		Yes
Constant scan		0.5 to 2000ms (Setting available in 0.5ms unit.)
Program capacity		20k steps (80k byte)
CPU shared memory	QCPU standard memory	8k bytes
	Multiple CPU high speed transmission area	32k bytes
No. of I/O device points (X/Y)		8192 points
No. of I/O points (X/Y)		512 points
Internal relay (M)	Points by default (changeable by parameters)	8192 points
Latch relay (L)		8192 points
Link relay (B)		8192 points
Timer (T)		2048 points
Retentive timer (ST)		0 points
Counter (C)		1024 points
Data register (D)		12288 points
Link register (W)		8192 points
Annunciator (F)		2048 points
Edge relay (V)		2048 points
Link special relay (SB)		2048 points
Link special register (SW)		2048 points
File register (R, ZR)		98304 points
Step relay (S)		8192 points
Index register/Standard devise register (Z)	20 points	
Index register (Z) (32-bit modification specification of ZR device)	Up to 10 points (Z0 to Z18) (Index register (Z) is used in double words.)	
Pointer (P)	4096 points	
Interrupt pointer (I)	256 points	
Special relay (SM)	2048 points	
Special register (SD)	2048 points	
Function input (FX)	16 points	
Function output (FY)	16 points	
Function register (FD)	5 points	
Local device	Yes	
Device initial values	Yes	

2 SYSTEM CONFIGURATION

PLC control specifications (continued)

Item		Specification
Extension base unit	Number of extensions	1 extension (Q52B/Q55B usable)
	GOT bus connection	<ul style="list-style-type: none"> Extension base unit use : Connection after the extension base unit of stage 1 Extension base unit not use : Direct bus connection to Motion controller
PC type when program is made by GX Developer		Q03UDCPU

(4) Q170MCPU names of parts

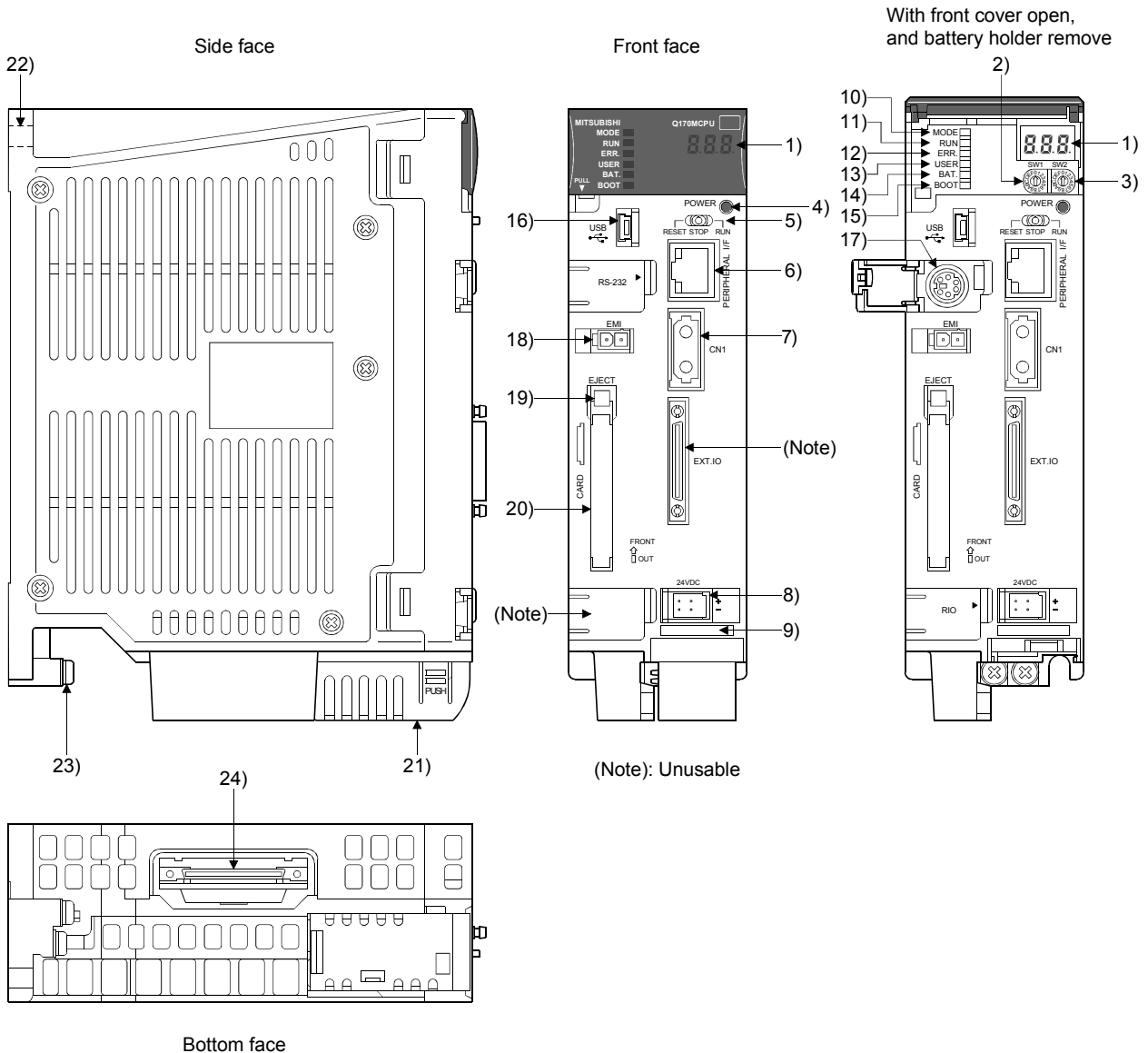

2 SYSTEM CONFIGURATION

No.	Name	Application
1)	7-segment LED	Indicates the operating status and error information.
2)	Rotary function select 1 switch (SW1)	<ul style="list-style-type: none"> Set the operation mode. (Normal operation mode, Installation mode, Mode operated by ROM, etc)
3)	Rotary function select 2 switch (SW2)	<ul style="list-style-type: none"> Each switch setting is 0 to F. (Factory default in SW1 "A", SW2 "0" position)
4)	"POWER" LED	<ul style="list-style-type: none"> ON (red) : The internal power (5VDC) is ON. OFF : The internal power (5VDC) is OFF.
5)	RUN/STOP/RESET switch	<ul style="list-style-type: none"> Move to RUN/STOP <ul style="list-style-type: none"> RUN : Sequence program/Motion SFC program is started. STOP : Sequence program/Motion SFC program is stopped. RESET (Momentary switch) <ul style="list-style-type: none"> Set the switch to the "RESET" position 1 second or more to reset the hardware.
6)	PERIPHERAL I/F connector	<p>For communication I/F with peripheral devices</p> <ul style="list-style-type: none"> Upper LED <ul style="list-style-type: none"> Remains flashing : It communicates with the personal computer. ON : It does not communicate with the personal computer. Lower LED <ul style="list-style-type: none"> Data transmission speed ON : 100Mbps OFF : 10Mbps
7)	SSCNETⅢ CN1 connector (Note-1)	Connector to connect the servo amplifier
8)	24VDC power supply connector	The DC power of 24VDC is connected.
9)	Serial number display	Displays the serial number described on the rating plate.
10)	"MODE" LED	<p>Indicates the mode of the PLC CPU area.</p> <ul style="list-style-type: none"> ON (green) : Q mode
11)	"RUN" LED	<p>Indicates the operating status of the PLC CPU area.</p> <ul style="list-style-type: none"> ON : During operation with the RUN/STOP/RESET switch set to "RUN". OFF : During stop with the RUN/STOP/RESET switch set to "STOP". <ul style="list-style-type: none"> When an error is detected and operation must be halted due to the error. Remains flashing : Parameters or programs are written with the RUN/STOP/RESET switch set to "STOP", and then the RUN/STOP/RESET switch is turned from "STOP" to "RUN". <ul style="list-style-type: none"> To turn ON the "RUN" LED after writing the program, carry out the following steps. <ol style="list-style-type: none"> Set the RUN/STOP/RESET switch in the order of "RUN" to "STOP" to "RUN". Reset with the RUN/STOP/RESET switch. Power ON the Motion controller again. To turn ON the "RUN" LED after writing the parameters, carry out the following steps. <ol style="list-style-type: none"> Reset with the RUN/STOP/RESET switch. Power ON the Motion controller again. <ul style="list-style-type: none"> (If the RUN/STOP/RESET is set in the order of "RUN" to "STOP" to "RUN" after changing the parameters, network parameters and intelligent function module parameters will not be updated.

2 SYSTEM CONFIGURATION

No.	Name	Application
12)	"ERR." LED	Indicates the operating status of the PLC CPU area. <ul style="list-style-type: none"> • ON : Detection of self-diagnosis error which will not stop operation, except battery error. (When operation continued at error detection is set in the parameter setting.) • OFF : Normal • Remains flashing : Detection of error whose occurrence stops operation. Resetting with the RUN/STOP/RESET switch becomes valid.
13)	"USER." LED	Indicates the operating status of the PLC CPU area. <ul style="list-style-type: none"> • ON : Annunciator (F) turned ON • OFF : Normal
14)	"BAT." LED	Indicates the operating status of the PLC CPU area. <ul style="list-style-type: none"> • ON (yellow) : Occurrence of battery error due to reduction in battery voltage of the memory card. • ON (green) : Turned ON for 5 seconds after restoring of data backup to the standard ROM by the latch data backup is completed. • Remains flashing (green): Backup of data to the standard ROM by latch data backup is completed. • OFF : Normal
15)	"BOOT." LED	Indicates the operating status of the PLC CPU area. <ul style="list-style-type: none"> • ON : Start of boot operation • OFF : Non-execution of boot operation
16)	USB connector	<ul style="list-style-type: none"> • Connector to connect the peripheral devices for USB connection (Connector type mini B) • Connect with the dedicated cable for USB
17)	RS-232 connector	<ul style="list-style-type: none"> • Connector to connect the peripheral devices for RS-232 connection • Connect with the dedicated cable (QC30R2) for RS-232
18)	Forced stop input connector (EMI) (Note-2)	Input to stop all axes of servo amplifier in a lump EMI ON (opened) : Forced stop EMI OFF (24VDC input) : Forced stop release
19)	Memory card EJECT button	Used to eject the memory card from the Motion controller
20)	Memory card loading connector	Connector used to load the memory card to the Motion controller
21)	Battery holder (Note-3)	Battery holder to set the Q6BAT/Q7BAT
22)	Module fixing screw hole (Note-4)	Hole for screw used to fix to the control panel
23)	FG terminal	Ground terminal connected with the shield pattern of the printed circuit board
24)	Extension cable connector	Connector for transfer of signals to/from the extension base unit.

(Note-1) : Put the SSCNET cable in the duct or fix the cable at the closest part to the Motion controller with bundle material in order to prevent SSCNET cable from putting its own weight on SSCNET connector.

(Note-2) : Be sure to use the cable for forced stop input (sold separately). The forced stop cannot be released without using it.

If the cable for forced stop input is fabricated on the customer side, make it within 30m(98.43ft.).











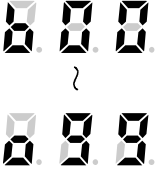

(Note-3) : Be sure to set the battery. The data (Refer to Section 6.5.) of RAM built-in Motion controller are not backed up if the battery cable is not set correctly.

(Note-4) : Purchase the M5 screws.

2 SYSTEM CONFIGURATION

(5) 7-segment LED display

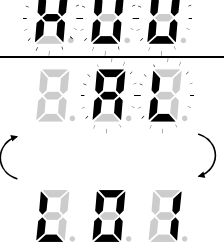
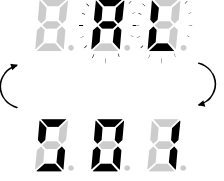
The LED displays/flashes in the combination with errors.

Item		7-segment LED	Remark
Start			Initializing It takes about 10 seconds to initialize (RUN/STOP display).
Normal			" *" remains flashing Normal operation
Installation mode			Steady "INS" display, " *" remains flashing Mode to install the operating system software via personal computer.
Operation mode	Mode operated by RAM		" *" remains flashing Mode to operate based on the user programs and parameters stored in the RAM built-in Motion controller.
	Mode operated by ROM		Steady ". " display, " *" remains flashing Mode to operate after the user programs and parameters stored in the FLASH ROM built-in Motion controller are read to the RAM built-in Motion controller.
STOP			Steady "STP" display Stopped the Motion SFC program with the PLC READY flag (M2000) OFF.
RUN			Steady "RUN" display Executed the Motion SFC with the PLC READY flag (M2000) ON.
Battery error	Early stage warning (2.7V or less)		Steady "BT1" display Displayed at battery voltage 2.7V or less. Refer to Section "6.5 Battery".
	Final stage warning (2.5V or less)		Steady "BT2" display Displayed at battery voltage 2.5V or less. Refer to Section "6.5 Battery".
Operating system software not installed			"A00" remains flashing It becomes the status of installation mode when the operating system software is not installed.
System setting error			"AL" flashes 3 times ↓ Steady "L01" display System setting error of the Motion controller Refer to the "Q173DCPU/Q172DCPU Motion controller Programming Manual (COMMON)" for details.
Servo error			"AL" flashes 3 times ↓ Steady "S01" display Servo error of the Motion controller Refer to the Programming Manual of the operating system software used for details.
WDT error			Steady "... " display Hardware fault or software fault Refer to the Programming Manual of the operating system software used for details.

2 SYSTEM CONFIGURATION

Item	7-segment LED	Remark
Self diagnostic error (Error related for Multiple CPU)	<p>"AL" flashes 3 times ↓ Steady "A1" display (Self-diagnosis error) ↓ 4-digits error code is displayed in two sequential flashes of 2-digits each. (ex. error code [3012])</p>	Setting error of the Multiple CPU system Refer to the "Q173DCPU/Q172DCPU Motion controller Programming Manual (COMMON)" for details.

POINTS

- (1) An error is displayed at the 7-segment LED, confirm the error code etc. using MT Developer2.
- (2) Refer to the Motion CPU error batch monitor of MT Developer2 or error list of Programming Manual for error details.

(6) Rotary switch assignment

(a) Rotary switch select 1 switch (SW1)

Rotary switch	Setting ^(Note)	Mode	Description
	0	Normal mode	Normal operation mode
	A	Installation mode	Installed the operating system software using MT Developer2

(Note): Not to be set except above setting.

(b) Rotary switch select 2 switch (SW2)

Rotary switch	Setting ^(Note)	Mode	Description
	0	Mode operated by RAM	Normal operation mode (Operation by the setting data and parameters stored in the RAM built-in Motion controller.)
	6	Mode operated by ROM	Mode to operate based on the setting data and parameters wrote to the FLASH ROM built-in Motion controller.
	8	Ethernet IP address display mode	Mode to display the Ethernet IP address.
	C	SRAM clear	SRAM "0" clear

(Note): Not to be set except above setting.

⚠ CAUTION

- Be sure to turn OFF the Motion controller's power supply before the rotary switch setting change.

2 SYSTEM CONFIGURATION

(7) Operation mode

(a) Rotary switch setting and operation mode

Rotary switch setting		Operation mode
SW1	SW2	
A	Any setting (Except C)	Installation mode
0	0	Mode operated by RAM
0	6	Mode operated by ROM
0	8	Ethernet IP address display mode
Any setting	C	SRAM clear ^(Note)

(Note) : The data (Refer to Section 6.5) of RAM built-in Motion controller are cleared.

(b) Operation mode overview

Operation mode	7-segment LED	Operation overview
Installation mode		<ul style="list-style-type: none"> Steady "INS" display at the 7-segment LED. Operating system software can be installed. It is STOP status regardless of the RUN/STOP/RESET switch position at the front side of Motion controller. Digital oscilloscope function cannot be used.
Mode operated by RAM		<ul style="list-style-type: none"> " . " remains flashing in the first digit of 7-segment LED. It operates based on the user programs and parameters stored in the RAM built-in Motion controller.
Mode operated by ROM		<ul style="list-style-type: none"> " . " remains flashing in the first digit and steady" . "display in the second digit of 7-segment LED. Operation starts after the user programs and parameters stored in the FLASH ROM built-in Motion controller are read to the RAM built-in Motion controller at power supply on or reset of the Motion controller. If the ROM writing is not executed, even if the user programs and parameters are changed using the MT Developer2 during mode operated by ROM, operation starts with the contents of the FLASH ROM built-in Motion controller at next power supply on or reset. Also, If the ROM writing is not executed, even if the auto tuning data are reflected on the servo parameter of Motion controller by operation in the auto-tuning setting, operation starts with the contents of the FLASH ROM built-in Motion controller at next power supply on or reset.
Ethernet IP address display mode	Refer to next page (c)	<ul style="list-style-type: none"> Refer to next page "(c) Ethernet IP address display mode overview". Digital oscilloscope function cannot be used.
SRAM clear		<ul style="list-style-type: none"> " . " remains flashing in the first digit of 7-segment LED. The data (Refer to Section 6.5) of RAM built-in Motion controller are cleared by turning ON the Motion controller's power supply after the rotary switch2 is set to "C".

POINTS

Be sure to turn OFF the Motion controller's power supply before the rotary switch setting change.

2 SYSTEM CONFIGURATION

(c) Ethernet IP address display mode overview

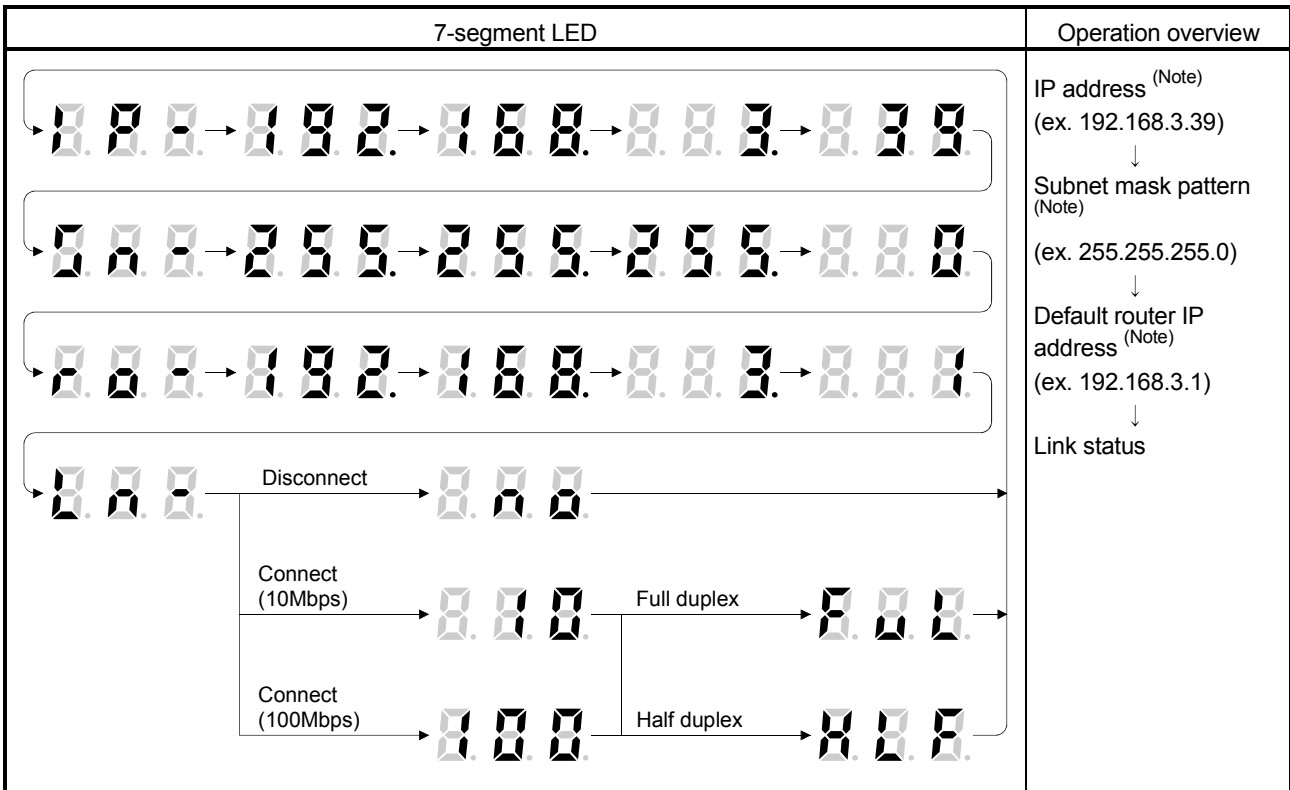

(Note): When the Ethernet parameters are not written in the Motion controller, the addresses are displayed as follows.

- IP address : 192.168.3.39
- Subnet mask pattern : 255.255.255.0
- Default router IP address : 192.168.3.1

(8) PERIPHERAL I/F connector

Item		Specification
Transmission	Data transmission speed	100Mbps/10Mbps
	Communication mode	Full-duplex/Half-duplex
	Transmission method	Base band
	Cable length [m(ft.)]	Up to 30 (98.43)

2 SYSTEM CONFIGURATION

(9) 24VDC power supply connector

(a) The pin layout of the 24VDC power supply connector

24VDC power supply is supplied from the 24VDC power supply connector of the front face of the Motion controller.

The pins layout (from front view) and connection of the 24VDC power supply connector is shown below.

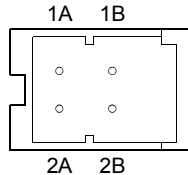

PIN No.	Signal name	PIN No.	Signal name
1A ^(Note)	24V(+)	1B	24V(+)
2A ^(Note)	24G	2B	24G

(Note): Use "1A" and "2A" when the 24VDC voltage is applied on EMI terminal and the forced stop input of EMI terminal is invalidated.

- Applicable connector model name

24VDC power supply connector set (Q170MPWCON) (Attachment)

1-1827864-2 connector (Tyco Electronics AMP K.K. make)

1827587-2 terminal

- Crimping tool

Tool type : 1762846-1

Maker name : Tyco Electronics AMP K.K.

- Conductor size for power line

0.34 to 0.37mm²

⚠ CAUTION

- 24V(+) pin is upper side and 24G pin is lower side of 24VDC power supply connector (from front view) of Motion controller. If the polarity is wrong, the unit may be damaged.
- Recommend the use of twisted pair cabling for 24VDC power line
- Power off the Motion controller before wiring 24VDC power supply.
- Use proper size wire for 24VDC power line.

2 SYSTEM CONFIGURATION

(10) Selection of the modules used in the extension base unit

The modules used in the extension base unit are selected according to the total of current consumption of the modules, and peripheral devices (Manual pulse generator, Incremental synchronous encoder, etc.) supplied by the Motion controller and Motion controller internal power supply.

5VDC internal current consumption of shared equipments with PLC might be changed. Be sure to refer to the MELSEC-Q series PLC Manuals.

(a) Calculation example of module selection

<System configuration>

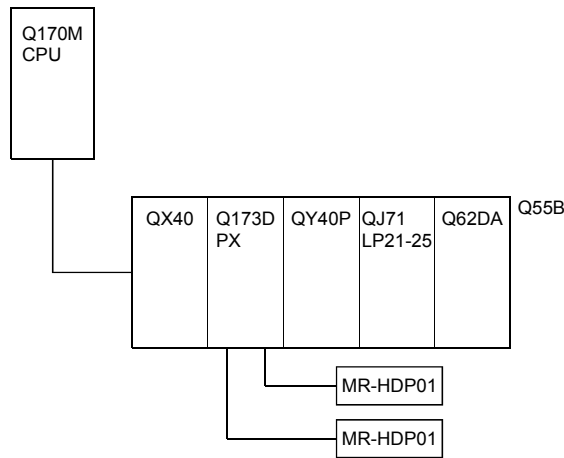

• 5VDC current consumption of each module

Q170M CPU	: 2.00 [A]	QY40P	: 0.065 [A]
QX40	: 0.05 [A]	QJ71LP21-25	: 0.55 [A]
Q173DPX	: 0.38 [A]	Q62DA	: 0.33 [A]
MR-HDP01	: 0.06 [A]	Q55B	: 0.10 [A]

• Power consumption of overall modules

$$I_{5V} = 2.00 + 0.05 + 0.38 + 0.06 \times 2 + 0.065 + 0.55 + 0.33 + 0.10 \\ = 3.595 \text{ [A]}$$

System configuration is possible because of the total of current consumption 3.595 [A] is the allowable value 4[A] or less.

POINT

Configure the system in such a way that the total current consumption at 5VDC of all the modules is the allowable value 4 [A] or less.

2 SYSTEM CONFIGURATION

2.5.2. Extension base unit and extension cable

This section describes the specifications of the extension cables for the base units (Extension base unit), and the specification standards of the extension base unit. 5VDC internal current consumption of base unit might be changed. Be sure to refer to the MELSEC-Q series PLC Manuals.

(1) Extension base unit specifications

Item \ Type	Q52B	Q55B
Number of I/O modules	2	5
Possibility of extension	Extendable	
Applicable module	Q series modules	
5VDC internal current consumption [A]	0.08	0.10
Fixing hole size	M4 screw hole or $\phi 4.5$ hole (for M4 screw)	
Exterior dimensions [mm(inch)]	106(W) \times 98(H) \times 44.1(D) (4.17(W) \times 3.86(H) \times 1.74(D))	189(W) \times 98(H) \times 44.1(D) (7.44(W) \times 3.86(H) \times 1.74(D))
Mass [kg]	0.14	0.23
Attachment	Fixing screw M4 \times 14 4 pieces	

(2) Extension cable specifications

The list below describes the specifications of the extension cables which can be used.

Item \ Type	QC05B	QC06B	QC12B	QC30B	QC50B	QC100B
Cable length[m(ft.)]	0.45(1.48)	0.6(1.97)	1.2(3.94)	3.0(9.84)	5.0(16.40)	10.0(32.81)
Application	Connection between the Motion controller and extension base unit					
Mass [kg]	0.15	0.16	0.22	0.40	0.60	1.11

POINT

Use the extension cable of 10m (32.8ft.) or less.

2 SYSTEM CONFIGURATION

(3) Names of parts of the extension base unit

Names of parts of the extension base unit are described below.

(a) Extension base unit (Q52B, Q55B)

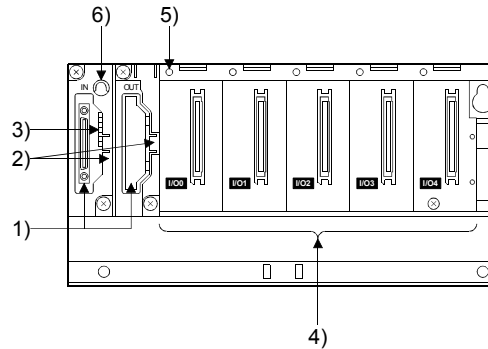

No.	Name	Application
1)	Extension cable connector	Connector for connecting an extension cable (for signal communications with the extension base unit)
2)	Base cover	Protective cover of extension cable connector. Before the GOT is connected, the area under the word "OUT" on the base cover must be removed with a tool such as nippers.
3)	Stage No. setting connector	Connector for setting the number of stages of extension base units. (Used for setting in stage 1.)
4)	Module connector	Connector for installing the Motion modules, I/O modules, and intelligent function module. To the connectors located in the spare space where these modules are not installed, attach the supplied connector cover or the blank cover module (QG60) to prevent entry of dirt.
5)	Module fixing screw hole	Screw hole for fixing the module to the extension base unit. Screw size: M3 × 12
6)	Base mounting hole	Hole for mounting this base unit onto the panel of the control panel (for M4 screw)

(4) I/O allocations

It is possible to allocate unique I/O No.s for each Motion CPU area independently of the PLC CPU area's I/O No.s.

ON/OFF data input to the Motion CPU area is handled via input devices PX□□, while ON/OFF data output from the Motion CPU area is handled via output devices PY□□.

It is not mandatory to match the I/O device PX/PY No.s used in the Motion program with the PLC I/O No.s; but it is recommended to make them match as much as possible.

The following figure shows an example of I/O allocation.

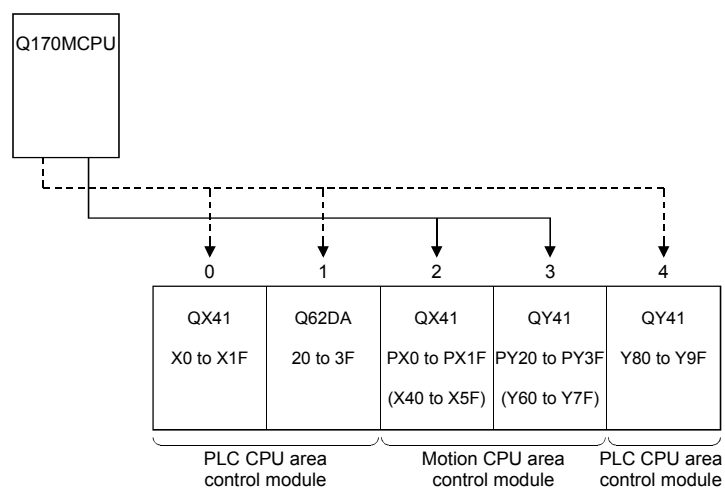

(Note-1) : When the number of modules to be installed is 32 points.

(Note-2) : When the PX/PY No. does not match the PLC I/O No.

Refer to the Q173DCPU/Q172DCPU Motion Controller Programming Manual (COMMON) about the I/O allocation setting method of the Motion CPU area, and refer to APPENDIX 1.6 and the "QCPU User's Manual (Function Explanation, Program Fundamentals)" about the I/O allocation setting method of the PLC CPU area.

POINT

I/O device of the Motion CPU area can be set in the range PX/PY000 to PX/PYFFF. The real I/O points must be 256 points or less. (As for the I/O No., it is possible not to continue.)

2 SYSTEM CONFIGURATION

2.5.3 Q172DLX Servo external signals interface module

Q172DLX receives external signals (servo external signals) required for positioning control.

(1) Q172DLX name of parts

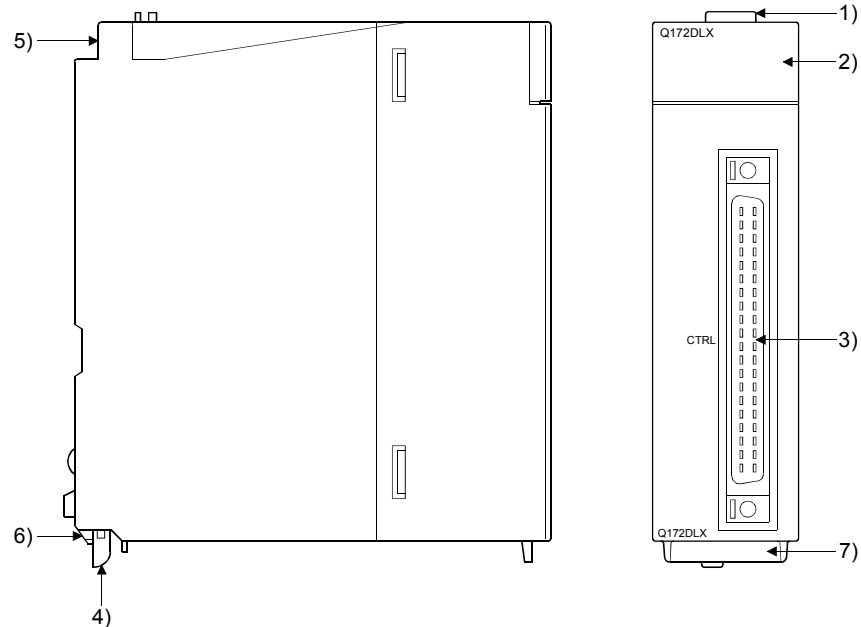

No.	Name	Application				
1)	Module fixing hook	Hook used to fix the module to the base unit. (Single-motion installation)				
2)	Mode judging LED	Display the servo external input status from the external equipment. <table border="1" style="width: 100%; border-collapse: collapse;"> <thead> <tr> <th style="width: 15%;">LED</th> <th>Details</th> </tr> </thead> <tbody> <tr> <td style="text-align: center;">0 to 1F</td> <td>Display for servo external signal input status of each axis.</td> </tr> </tbody> </table> <p>The proximity dog/speed-position switching signal (DOG/CHANGE) does not turn ON without setting Q172DLX in the system setting.</p>	LED	Details	0 to 1F	Display for servo external signal input status of each axis.
LED	Details					
0 to 1F	Display for servo external signal input status of each axis.					
3)	CTRL connector	The servo external signal input connector of each axis.				
4)	Module mounting lever	Used to install the module to the base unit.				
5)	Module fixing screw hole	Hole for the screw used to fix to the base unit. (M3×12 screw : Purchase from the other supplier)				
6)	Module fixing projection	Projection used to fix to the base unit.				
7)	Serial number display	Display the serial number described on the rating plate.				

POINT

Mode judging LED of the proximity dog/speed-position switching signal (DOG/CHANGE) turns ON at the following conditions.

- Q172DLX is set on the system setting of MT Developer2.
- The proximity dog/speed-position switching signal (DOG/CHANGE) is input.

2 SYSTEM CONFIGURATION

(2) Performance specifications (a) Module specifications

Item	Specifications
Number of I/O occupying points	32 points(I/O allocation: Intelligent, 32 points)
Internal current consumption(5VDC) [A]	0.06
Exterior dimensions [mm(inch)]	98(H)× 27.4(W)×90(D) (3.86(H)×1.08(W)×3.54(D))
Mass [kg]	0.15

(b) Input

Item	Specifications
Number of input points	Servo external signals : 32 points (Upper stroke limit, Lower stroke limit, Stop input, Proximity dog/Speed-position switching signal) (4 points × 8 axes)
Input method	Sink/Source type
Isolation method	Photocoupler
Rated input voltage	12/24VDC
Rated input current	12VDC 2mA/24VDC 4mA
Operating voltage range	10.2 to 26.4VDC (12/24VDC +10/-15%, ripple ratio 5% or less)
ON voltage/current	10VDC or more/2.0mA or more
OFF voltage/current	1.8VDC or less/0.18mA or less
Input resistance	Approx. 5.6kΩ
Response time of the Upper/Lower stroke limit and STOP signal	OFF to ON ON to OFF 1ms
Response time of the proximity dog, Speed- position switching signal	OFF to ON ON to OFF 0.4ms/0.6ms/1ms (CPU parameter setting, Default 0.4ms)
Common terminal arrangement	32 points/common (common terminal: B1, B2)
Indicates to display	ON indication (LED)
External connector type	40 pin connector
Applicable wire size	0.3mm ²
Applicable connector for the external connection	A6CON1 (Attachment), A6CON2, A6CON3, A6CON4 (Optional)
Applicable connector/ Terminal block converter module	A6TBXY36, A6TBXY54, A6TBX70 (Optional)

2 SYSTEM CONFIGURATION

(3) Connection of servo external signals interface module

(a) Servo external signals

There are the following servo external signals.

(Upper stroke limit is limit value of address increase direction/lower stroke limit is limit value of an address decrease direction.)

The Q172DLX is assigned a set of input No.s per axis. Make the system setting of MT Developer2 to determine the I/O No.s corresponding to the axis No.s.

Servo external signal	Application	Number of points on one Q172DLX
Upper stroke limit input (FLS)	For detection of upper and lower stroke limits.	32 points (4 points/8 axes)
Lower stroke limit input (RLS)		
Stop signal input (STOP)	For stopping under speed or positioning control.	
Proximity dog/ Speed-position switching input (DOG/CHANGE)	For detection of proximity dog at proximity dog or count type home position return of for switching from speed to position switching control.	

2 SYSTEM CONFIGURATION

(b) The pin layout of the CTRL connector

Use the CTRL connector at the Q172DLX module front to connect the servo external signals.

The pin layout of the Q172DLX CTRL connector viewed from the front is shown below.

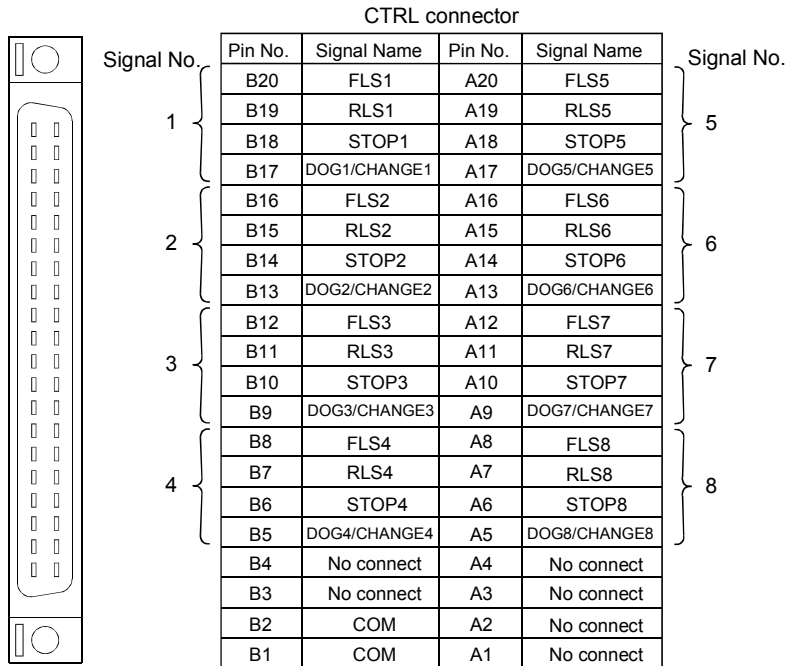

Applicable connector model name

- A6CON1 type soldering type connector
 - FCN-361J040-AU connector (FUJITSU COMPONENT LIMITED)
 - FCN-360C040-B connector cover
- } (Attachment)
- A6CON2 type Crimp-contact type connector
 - A6CON3 type Pressure-displacement type connector
 - A6CON4 type soldering type connector
- } (Optional)

DOG/CHANGE, STOP, RLS, FLS functions of each axis(1 to 8)	
DOG/CHANGE	Proximity dog/Speed-position switching signal
STOP	Stop signal
RLS	Lower stroke limit
FLS	Upper stroke limit

For information about signal details, refer to the programming manual.

(Note) : Connector/terminal block conversion modules and cables can be used at the wiring of CTRL connector.

A6TBXY36/A6TBXY54/A6TBX70 : Connector/terminal block converter module

AC□TB (□:Length [m]) : Connector/terminal block converter module cable

POINT

Signal No. 1 to 8 can be assigned to the specified axis. Make the assignment in the system settings of MT Developer2.

2 SYSTEM CONFIGURATION

(4) Interface between CTRL connector and servo external signal

Input or Output	Signal name	PIN No.	LED	Wiring example	Internal circuit	Specification	Description
Input	FLS1	B20	0	Upper stroke limit input	5.6k Ω	• Supply voltage 12 to 24 VDC (10.2 to 26.4 VDC, stabilized power supply)	FLS
	FLS2	B16	4				
	FLS3	B12	8				
	FLS4	B8	C				
	FLS5	A20	10				
	FLS6	A16	14				
	FLS7	A12	18				
	FLS8	A8	1C				
	RLS1	B19	1	Lower stroke limit input	5.6k Ω	• High level 10.0 VDC or more/ 2.0mA or more	RLS
	RLS2	B15	5				
	RLS3	B11	9				
	RLS4	B7	D				
	RLS5	A19	11				
	RLS6	A15	15				
	RLS7	A11	19				
	RLS8	A7	1D				
	STOP1	B18	2	Stop signal input	5.6k Ω	• Low level 1.8 VDC or less/ 0.18mA or less	STOP
	STOP2	B14	6				
	STOP3	B10	A				
	STOP4	B6	E				
	STOP5	A18	12				
	STOP6	A14	16				
	STOP7	A10	1A				
	STOP8	A6	1E				
DOG/CHANGE1	B17	3	Proximity dog/ Speed-position switching signal	5.6k Ω		DOG/CHANGE	
DOG/CHANGE2	B13	7					
DOG/CHANGE3	B9	B					
DOG/CHANGE4	B5	F					
DOG/CHANGE5	A17	13					
DOG/CHANGE6	A13	17					
DOG/CHANGE7	A9	1B					
DOG/CHANGE8	A5	1F					
Power supply (Note)		B1 B2					Common terminals for servo external input signal.
				12VDC to 24VDC			

(Note): As for the connection to power line (B1, B2), both "+" and "-" are possible.

⚠ CAUTION

- Always use a shield cable for connection of the CTRL connector and external equipment, and avoid running it close to or bundling it with the power and main circuit cables to minimize the influence of electromagnetic interface. (Separate them more than 200mm (0.66ft.) away.)
- Connect the shield wire of the connection cable to the FG terminal of the external equipment.
- Make parameter setting correctly. Incorrect setting may disable the protective functions such as stroke limit protection.
- Always wire the cables when power is off. Not doing so may damage the circuit of modules.
- Wire the cable correctly. Wrong wiring may damage the internal circuit.

2 SYSTEM CONFIGURATION

2.5.4 Q173DPX Manual pulse generator interface module

Q173DPX receive signals required for Manual pulse and Incremental synchronous encoder (Voltage-output/Open-collector type/Differential-output type) input.

(1) Q173DPX name of parts

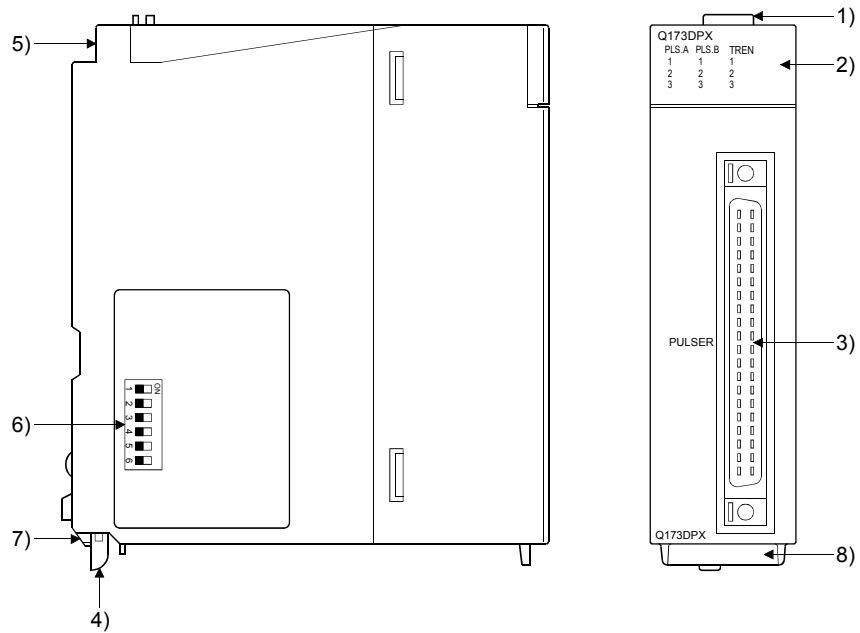

No.	Name	Application						
1)	Module fixing hook	Hook used to fix the module to the base unit. (Single-motion installation)						
2)	Mode judging LED	<p>Display the input status from the external equipment.</p> <table border="1"> <thead> <tr> <th>LED</th> <th>Details</th> </tr> </thead> <tbody> <tr> <td>PLS.A 1 to 3 PLS.B 1 to 3</td> <td>Display for input signal status of manual pulse generator/incremental synchronous encoder phases A, B</td> </tr> <tr> <td>TREN 1 to 3</td> <td>Display for signal status of tracking enable.</td> </tr> </tbody> </table> <p>The manual pulse generator/incremental synchronous encoder phases A, B and tracking enable signal does not turn ON without setting Q173DPX in the system setting.</p>	LED	Details	PLS.A 1 to 3 PLS.B 1 to 3	Display for input signal status of manual pulse generator/incremental synchronous encoder phases A, B	TREN 1 to 3	Display for signal status of tracking enable.
LED	Details							
PLS.A 1 to 3 PLS.B 1 to 3	Display for input signal status of manual pulse generator/incremental synchronous encoder phases A, B							
TREN 1 to 3	Display for signal status of tracking enable.							
3)	PULSER connector	Input connector of the Manual pulse generator/Incremental synchronous encoder.						
4)	Module mounting lever	Used to install the module to the base unit.						
5)	Module fixing screw hole	Hole for the screw used to fix to the base unit (M3×12 screw : Purchase from the other supplier)						

2 SYSTEM CONFIGURATION

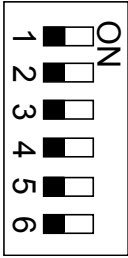
No.	Name	Application
6)	Dip switches (Note-1)  (Factory default in OFF position)	Dip switch 1 SW1 SW2 OFF OFF } TREN is detected at leading edge of TREN signal. ON ON } Dip switch 2 ON OFF } OFF ON } TREN is detected at trailing edge of TREN signal.
		Dip switch 3 SW3 SW4 OFF OFF } TREN is detected at leading edge of TREN signal. ON ON } Dip switch 4 ON OFF } OFF ON } TREN is detected at trailing edge of TREN signal.
		Dip switch 5 SW5 SW6 OFF OFF } TREN is detected at leading edge of TREN signal. ON ON } Dip switch 6 ON OFF } OFF ON } TREN is detected at trailing edge of TREN signal.
		Dip switch 5 SW5 SW6 OFF OFF } TREN is detected at leading edge of TREN signal. ON ON } Dip switch 6 ON OFF } OFF ON } TREN is detected at trailing edge of TREN signal.
		Dip switch 5 SW5 SW6 OFF OFF } TREN is detected at leading edge of TREN signal. ON ON } Dip switch 6 ON OFF } OFF ON } TREN is detected at trailing edge of TREN signal.
		Dip switch 5 SW5 SW6 OFF OFF } TREN is detected at leading edge of TREN signal. ON ON } Dip switch 6 ON OFF } OFF ON } TREN is detected at trailing edge of TREN signal.
7)	Module fixing projection	Projection used to fix to the base unit.
8)	Serial number display	Display the serial number described on the rating plate.

(Note-1) : The function is different according to the operating system software installed.

⚠ CAUTION

- Before touching the DIP switches, always touch grounded metal, etc. to discharge static electricity from human body. Failure to do so may cause the module to fail or malfunction.
- Do not directly touch the module's conductive parts and electronic components. Touching them could cause an operation failure or give damage to the module.

POINTS

Mode judging LED of the manual pulse generator/incremental synchronous encoder phases A, B and tracking enable signal turns ON at the following conditions.

- (1) PLS.A 1 to 3, PLS.B 1 to 3
 - Q173DPX is set in the system setting of MT Developer2.
 - All axes servo ON command (M2042) turned on.
 - Manual pulse generator enable flag (M2051, M2052, M2053) turned on.
 - Manual pulse generator signal is input.
- (2) TREN 1 to 3
 - Q173DPX is set in the system setting of MT Developer2.
 - The tracking enable signal is input.

2 SYSTEM CONFIGURATION

(2) Performance specifications

(a) Module specifications

Item	Specifications
Number of I/O occupying points	32 points(I/O allocation: Intelligent, 32 points)
Internal current consumption(5VDC)[A]	0.38
Exterior dimensions [mm(inch)]	98(H)×27.4(W)×90(D) (3.86(H)×1.08(W)×3.54(D))
Mass [kg]	0.15

(b) Tracking enable signal input

Item	Specifications	
Number of input points	Tracking enable signal : 3 points	
Input method	Sink/Source type	
Isolation method	Photocoupler	
Rated input voltage	12/24VDC	
Rated input current	12VDC 2mA/24VDC 4mA	
Operating voltage range	10.2 to 26.4VDC (12/24VDC +10/ -15%, ripple ratio 5% or less)	
ON voltage/current	10VDC or more/2.0mA or more	
OFF voltage/current	1.8VDC or less/0.18mA or less	
Input resistance	Approx. 5.6kΩ	
Response time	OFF to ON	0.4ms/0.6ms/1ms (CPU parameter setting, Default 0.4ms)
	ON to OFF	
Common terminal arrangement	1 point/common(Common contact: TREN.COM)	
Indicates to display	ON indication(LED)	

(Note): Functions are different depending on the operating system software installed.

(c) Manual pulse generator/Incremental synchronous encoder input

Item	Specifications	
Number of modules	3/module	
Voltage-output/ Open-collector type	High-voltage	3.0 to 5.25VDC
	Low-voltage	0 to 1.0VDC
Differential-output type (26LS31 or equivalent)	High-voltage	2.0 to 5.25VDC
	Low-voltage	0 to 0.8VDC
Input frequency	Up to 200kpps (After magnification by 4)	
Applicable types	Voltage-output type/Open-collector type (5VDC), Recommended product: MR-HDP01, Differential-output type: (26LS31 or equivalent)	
External connector type	40 pin connector	
Applicable wire size	0.3mm ²	
Applicable connector for the external connection	A6CON1(Attachment) A6CON2, A6CON3, A6CON4 (Optional)	
Cable length	Voltage-output/ Open-collector type	30m (98.43ft.) (Open-collector type: 10m (32.81ft.))
	Differential-output type	

(3) Connection of manual pulse generator

Manual pulse generators are available in voltage-output/open-collector type and differential-output type. Since these types differ in connection method, design according to the connection method of section 2.5.4(5).

In addition the usable numbers of manual pulse generator which can be used with the Motion controller are up to 3 modules.

Motion controller	Manual pulse generator
Q170MCPU	Up to 3 modules (Q173DPX: Up to 1 module)

(4) Connection of incremental synchronous encoder

Incremental synchronous encoders are available in voltage-output/Open-collector type and differential-output type. Since these types differ in connection method, design according to the connection method of section 2.5.4(5).

In addition, the usable synchronous encoder is up to 8.

Motion controller	Synchronous encoder
Q170MCPU	Up to 8 modules (Q173DPX: Up to 3 modules)

- Tracking enable signal

Tracking enable signal of Q173DPX is used to start the input from incremental synchronous encoders.

The external input signal of the incremental synchronous encoder is indicated below.

This signal is used as the input start signal or high-speed reading function from incremental synchronous encoder.

External input signal of the incremental synchronous encoder	Application	Number of points on one Q173DPX
Tracking enable signal input	Input start function from incremental synchronous encoder	Each 1 point (Total 3 points)

2 SYSTEM CONFIGURATION

(5) Connection of manual pulse generator interface module

(a) The pin layout of the PULSER connector

Use the PULSER connector at the Q173DPX module front to connect the manual pulse signals, incremental synchronous encoder signals.

The pin layout of the Q173DPX PULSER connector viewed from the front is shown below.

PULSER connector

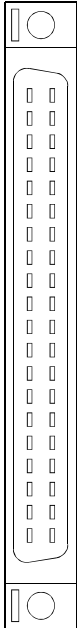

Pin No.	Signal Name	Pin No.	Signal Name		
2)...	B20	HB1	A20	HA1	... 2)
	B19	SG	A19	SG	
	B18	5V	A18	HPSEL1	... 1)
3) {	B17	HA1N	A17	HA1P	} 3)
	B16	HB1N	A16	HB1P	
2)...	B15	HB2	A15	HA2	... 2)
	B14	SG	A14	SG	
	B13	5V	A13	HPSEL2	... 1)
3) {	B12	HA2N	A12	HA2P	} 3)
	B11	HB2N	A11	HB2P	
2)...	B10	HB3	A10	HA3	... 2)
	B9	SG	A9	SG	
	B8	5V	A8	HPSEL3	... 1)
3) {	B7	HA3N	A7	HA3P	} 3)
	B6	HB3N	A6	HB3P	
	B5	No connect	A5	No connect	
	B4	TREN1 -	A4	TREN1 +	
	B3	TREN2 -	A3	TREN2 +	
	B2	TREN3 -	A2	TREN3 +	
4)...	B1	FG	A1	FG	... 4)

Applicable connector model name

A6CON1 type soldering type connector	} (Attachment)
FCN-361J040-AU connector (FUJITSU COMPONENT LIMITED)	
FCN-360C040-B connector cover	
A6CON2 type Crimp-contact type connector	} (Optional)
A6CON3 type Pressure-displacement type connector	
A6CON4 type soldering type connector	

- 1) : Input type from manual pulse generator/incremental synchronous encoder switched by HPSEL □.
Not connection : Voltage-output type/open-collector type.
HPSEL □-SG connection : Differential-output type.
(Switching is possible for each input 1 to 3)
- 2) : Voltage-output/open-collector type
Connect the A-phase signal to HA1/HA2/HA3, and the B-phase signal to HB1/HB2/HB3.
- 3) : Differential-output type
Connect the A-phase signal to HA1P/HA2P/HA3P, and the A-phase inverse signal to HA1N/HA2N/HA3N.
Connect the B-phase signal to HB1P/HB2P/HB3P, and the B-phase inverse signal to HB1N/HB2N/HB3N.
- 4) : Connect the shield cable between manual pulse generator/incremental synchronous encoder and Q173DPX at the FG signal.
- 5) : Connector/terminal block conversion modules cannot be used.

2 SYSTEM CONFIGURATION

(b) Interface between PULSER connector and manual pulse generator (Differential-output type)/Incremental synchronous encoder

Interface between Manual pulse generator (Differential-output type)/ Incremental synchronous encoder

Input or Output	Signal name		Pin No.			Wiring example	Internal circuit	Specification	Description
			PULSER connector						
			Differential-output type						
1	2	3							
Input	Manual pulse generator, phase A	A+ HA□P	A17	A12	A7		<ul style="list-style-type: none"> Rated input voltage 5.5VDC or less HIGH level 2.0 to 5.25VDC LOW level 0.8VDC or less 26LS31 or equivalent 	<p>For connection manual pulse generator Phases A, B</p> <ul style="list-style-type: none"> Pulse width $20\mu\text{s}$ or more Leading edge, Trailing edge time $\dots 1\mu\text{s}$ or less. Phase difference <p>Phase A Phase B </p> <p>(1) Positioning address increases if Phase A leads Phase B. (2) Positioning address decreases if Phase B leads Phase A.</p>	
		Manual pulse generator, phase B	B+ HB□P	A16	A11				A6
			B- HB□N	B16	B11				B6
		Select type signal HPSEL□	A18	A13	A8	(Note-2)			
Power supply		P5 ^(Note-1)	B18	B13	B8				
		SG	A19 B19	A14 B14	A9 B9				

(Note-1) : The 5V(P5)DC power supply from the Q173DPX must not be connected if a separated power supply is used as the Manual pulse generator/Incremental synchronous encoder power supply. Use a 5V stabilized power supply as a separated power supply. Any other power supply may cause a failure.

(Note-2) : Connect HPSEL□ to the SG terminal if the manual pulse generator (differential-output type) /incremental synchronous encoder is used.

2 SYSTEM CONFIGURATION

(c) Interface between PULSER connector and manual pulse generator (Voltage-output/Open-collector type)/ Incremental synchronous encoder.

Interface between Manual pulse generator (Voltage-output/Open-collector type)/Incremental synchronous encoder

Input or Output	Signal name	Pin No.			Wiring example	Internal circuit	Specification	Description
		PULSER connector						
		Voltage-output type						
1	2	3						
Input	Manual pulse generator, phase A HA□	A20	A15	A10		<ul style="list-style-type: none"> Rated input voltage 5.5VDC or less HIGH level 3 to 5.25VDC/ 2mA or less LOW level 1VDC or less/ 5mA or more 	For connection manual pulse generator Phases A, B <ul style="list-style-type: none"> Pulse width 20μs or more Leading edge, Trailing edge time 1μs or less. Phase difference 	
	Manual pulse generator, phase B HB□	B20	B15	B10				
	Select type signal HPSEL□	A18	A13	A8				
Power supply	P5 ^(Note)	B18	B13	B8				
	SG	A19 B19	A14 B14	A9 B9				

(Note) : The 5V(P5)DC power supply from the Q173DPX must not be connected if a separated power supply is used as the Manual pulse generator/Incremental synchronous encoder power supply. Use a 5V stabilized power supply as a separated power supply. Any other power supply may cause a failure.

(d) Interface between PULSER connector and tracking enable signal

Interface between tracking enable signal

Input or Output	Signal name	Pin No.			Wiring example	Internal circuit	Specification	Description
		PULSER connector						
		1	2	3				
Input	Tracking enable	TREN□+	A4	A3	A2			Tracking enable signal input.
		TREN□-	B4	B3	B2			

(Note) : As for the connection to tracking enable (TREN□+, TREN□-), both "+" and "-" are possible.

2 SYSTEM CONFIGURATION

(6) Connection examples of manual pulse generator

Connection of manual pulse generator
(Voltage-output/Open-collector type)

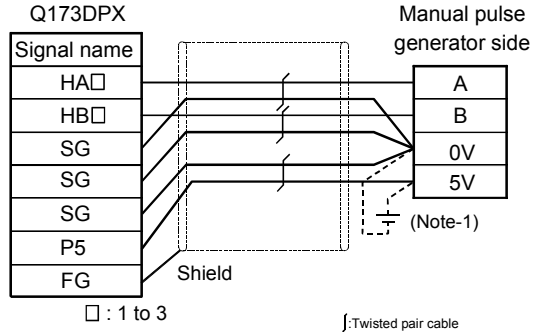

Connection of manual pulse generator
(Differential-output type)

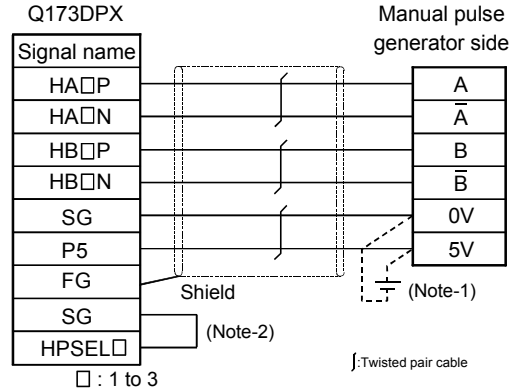

(Note-1) : The 5V(P5)DC power supply from the Q173DPX must not be connected if a separated power supply is used as the Manual pulse generator/Incremental synchronous encoder power supply.

Use a 5V stabilized power supply as a separated power supply. Any other power supply may cause a failure.

(Note-2) : Connect HPSEL□ to the SG terminal if the manual pulse generator (differential-output type)/incremental synchronous encoder is used.

⚠ CAUTION

- If a separate power supply is used as the manual pulse generator/incremental synchronous encoder power supply, use a 5V stabilized power supply. Any other power supply may cause a failure.
- Always wire the cables when power is off. Not doing so may damage the circuit of modules.
- Wire the cable correctly. Wrong wiring may damage the internal circuit.

2 SYSTEM CONFIGURATION

2.5.5 Manual pulse generator

(1) Manual pulse generator specifications

Item	Specifications
Model name	MR-HDP01 ^(Note-1)
Ambient temperature	-10 to 60°C(14 to 140°F)
Pulse resolution	25PLS/rev(100 PLS/rev after magnification by 4)
Output method	Voltage-output/Output current : Up to 20mA
Power supply voltage	4.5 to 13.2VDC ^(Note-2)
Current consumption [mA]	60
Life time	1,000,000 revolutions or more (at 200r/min)
Permitted axial loads	Radial load : Up to 19.6N, Thrust load : Up to 9.8N
Mass [kg]	0.4
Number of max. revolution	Instantaneous Up to 600r/min. normal 200r/min
Pulse signal status	2 signals : A phase, B : phase, 90° phase difference
Start friction torque	0.06N·m (20°C (68°F))

(Note-1) : Use MR-HDP01 by connecting with Q173DPX.

(Note-2) : If a separate power supply is used, use a stabilized power supply of voltage 5VDC ± 0.25V.

2 SYSTEM CONFIGURATION

2.5.6 SSCNET III cables

Between the Motion controller and servo amplifiers, or servo amplifier and servo amplifier connected by SSCNET III cable. Up to 16 servo amplifiers can be connected.

(1) SSCNET III cable specifications

Model name	Cable length [m(ft.)]	Description
MR-J3BUS□M	MR-J3BUS015M	0.15 (0.49)
	MR-J3BUS03M	0.3 (0.98)
	MR-J3BUS05M	0.5 (1.64)
	MR-J3BUS1M	1 (3.28)
	MR-J3BUS3M	3 (9.84)
MR-J3BUS□M-A	MR-J3BUS5M-A	5 (16.40)
	MR-J3BUS10M-A	10 (32.81)
	MR-J3BUS20M-A	20 (65.62)
MR-J3BUS□M-B	MR-J3BUS30M-B	30 (98.43)
	MR-J3BUS40M-B	40 (131.23)
	MR-J3BUS50M-B	50 (164.04)

• Q170MCPU ↔ MR-J3-□B
• MR-J3-□B ↔ MR-J3-□B

(2) Connection between the Q170MCPU and servo amplifiers

Connect the SSCNET III cables to the following connectors.

Refer to Section 4.2.1 for the connection and disconnection of SSCNET III cable.

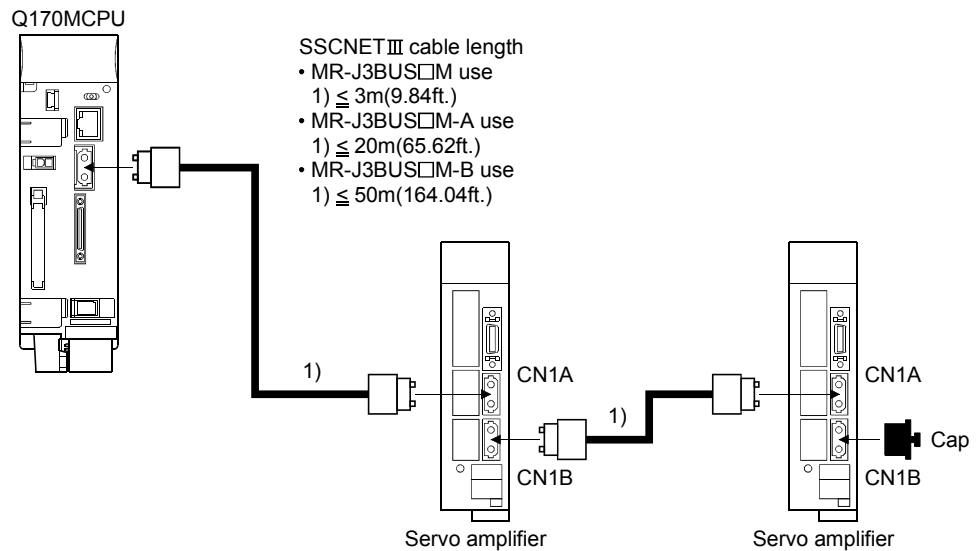

(Note): It cannot communicate with that the connection of CN1A and CN1B is mistaken.

2 SYSTEM CONFIGURATION

(3) Setting of the axis No. and axis select switch of servo amplifier

Axis No. is used to set the axis numbers of servo amplifiers connected to SSCNET III connector in the program.

Axis No. of 1 to 16 can be set.

Axis No. is set in the system setting of MT Developer2. Axis No. (1 to 16) is allocated and set for the setting axis number (d01 to d16) of servo amplifier.

Since the axis number (d01 to d16) of servo amplifier on the system setting screen corresponds to axis select switch (0 to F) of servo amplifier, set the axis select switch referring to the table below.

- Setting display of axis No.

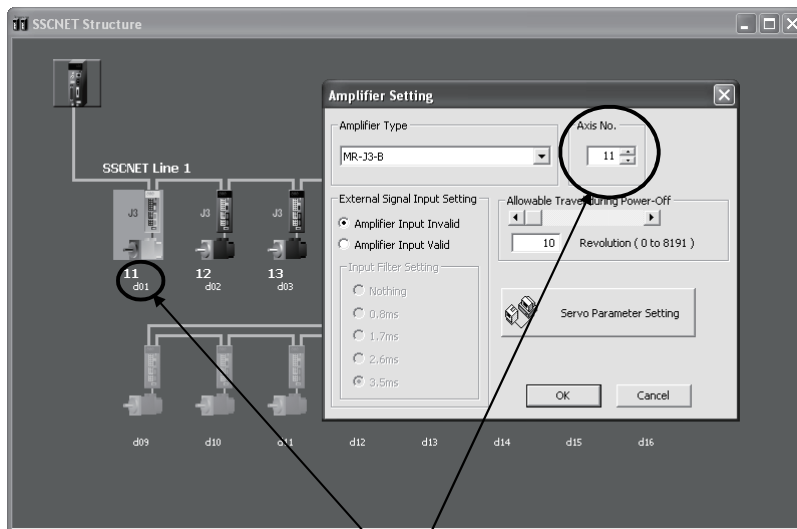

- Axis select switch (Servo amplifier)

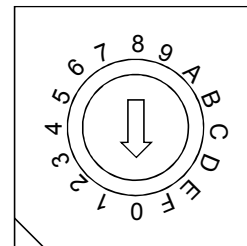

- Set the axis No. relative to axis number (dno.).

(Note) : Correspondence between dno. and axis select switch of servo amplifiers is shown below.

Correspondence between dno.s and axis select switches of servo amplifier

dno. (Note)	SSCNET III system	Axis select switch of servo amplifier	dno. (Note)	SSCNET III system	Axis select switch of servo amplifier
d01	1	"0"	d09	1	"8"
d02	1	"1"	d10	1	"9"
d03	1	"2"	d11	1	"A"
d04	1	"3"	d12	1	"B"
d05	1	"4"	d13	1	"C"
d06	1	"5"	d14	1	"D"
d07	1	"6"	d15	1	"E"
d08	1	"7"	d16	1	"F"

(Note) : The dno. is number of servo amplifier axis displayed with the system setting of MT Developer2. Axis No. is set relative to dno. in the system settings.

2 SYSTEM CONFIGURATION

2.5.7 Battery

This section describes the battery specifications and, handling precautions used in the Motion controller.

(1) Battery specifications

Item	Model name	Q6BAT	Q7BAT
Classification		Manganese dioxide lithium primary battery	
Initial voltage [V]		3.0	
Nominal current [mAh]		1800	5000
Storage life		Actually 5 years (Room temperature)	
Lithium content [g]		0.49	1.52
Applications		For memory data backup of RAM built-in Motion controller	
Exterior dimensions [mm(inch)]		$\phi 16(0.63) \times 32(1.26)$	$\phi 24(0.94) \times 52(2.05)$

(Note) : The 44th Edition of the IATA (International Air Transportation Association) Dangerous Goods Regulations was effected in January 1st, 2003 and administered immediately.

In this edition, the provisions relating to lithium and lithium ion batteries have been revised to strengthen regulations on the air transportation of battery.

This battery is not dangerous goods (not class 9). Therefore, these batteries of 24 units or less are not subject to the regulations.

These batteries more than 24 units require packing based on Packing Instruction 903.

If you need the self-certification form for the battery safety test, contact Mitsubishi.

For more information, contact Mitsubishi.

2 SYSTEM CONFIGURATION

(2) Data back-up of Motion controller by the battery

Be sure to set the battery to the Motion controller.

Set the battery (Q6BAT/Q7BAT) to battery holder.

The data (Refer to Section 6.5.) of RAM built-in Motion controller are backed up without using the battery.

In the following status, the backup time after power OFF is 3 minutes.

- The Q6BAT/Q7BAT lead connector is disconnected.
- The lead wire of Q6BAT/Q7BAT is broken.

Battery type	Battery life (Total power failure time) [h] ^(Note-1)				
	Power-on time ratio ^(Note-2)	Guaranteed value ^(Note-3) (MIN) (75°C (167°F))	Guaranteed value ^(Note-4) (TYP) (40°C (104°F))	Actual service value ^(Note-5) (Reference value) (TYP) (25°C (77°F))	Backup time after alarm
Q6BAT	0%	13000	40000	43800	90 (After SM51/SM52 ON)
	30%	18000	43800		
	50%	21000			
	70%	24000			
	100%	43800			
Q7BAT (Large capacity)	0%	39000	43800	43800	
	30%	43800			
	50%				
	70%				
	100%				

(Note-1) : The actual service value indicates the average value, and the guaranteed value indicates the minimum value.

(Note-2) : The power-on time ratio indicates the ratio of Motion controller power-on time to one day (24 hours).

(When the total power-on time is 17 hours and the total power-off time is 7 hours, the power-on time ratio is 70%.)

(Note-3) : The guaranteed value (MIN) ; equivalent to the total power failure time that is calculated based on the characteristics value of the memory (SRAM) supplied by the manufacturer and under the storage ambient temperature range of -25°C to 75°C (-13 to 167°F) (operating ambient temperature of 0°C to 55°C (32 to 131°F)).

(Note-4) : The guaranteed value (TYP) ; equivalent to the total power failure time that is calculated based on the normal air-conditioned environment (40°C (104°F)).

(Note-5) : The actual service value (Reference value) ; equivalent to the total power failure time that is calculated based on the measured value and under the storage ambient temperature of 25°C (77°F). This value is intended for reference only, as it varies with characteristics of the memory.

POINTS

The self-discharge influences the life of battery without the connection to Motion controller. The battery should be exchanged approximately every 4 or 5 years. And, exchange the battery with a new one in 4 to 5 years even if a total power failure time is guaranteed value or less.

⚠ CAUTION

- Do not short a battery.
- Do not charge a battery.
- Do not disassemble a battery.
- Do not burn a battery.
- Do not overheat a battery.
- Do not solder the battery terminal.
- The data (Refer to Section 6.5.) of RAM built-in Motion controller are backed up without using the battery.

(3) Connection procedure with Motion controller

Set the battery (Q6BAT/Q7BAT) to the battery holder, and connect between the lead connector of battery and connector of Motion controller.

Put the lead wire in the battery holder, and set it to the Motion controller.

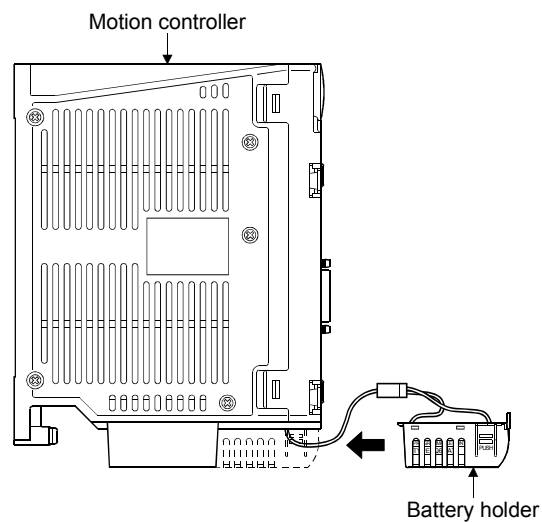

Refer to Section 4.1.4 for the mounting and removal of the battery holder and the connection of the battery lead wire.

2 SYSTEM CONFIGURATION

2.5.8 Forced stop input terminal

(1) Table of the forced stop input terminal specifications

Item		Specifications
Number of input points		Forced stop signal : 1 point
Input method		Sink/Source type
Rated input current		2.4mA
Isolation method		Photocoupler
Operating voltage range		20.4 to 26.4VDC (+10/ -15%, ripple ratio 5% or less)
ON voltage/current		17.5VDC or more/2.0mA or more
OFF voltage/current		1.8VDC or less/0.18mA or less
Input resistance		Approx. 10k Ω
Response time	OFF to ON	1ms or less
	ON to OFF	
External connector type		2 pin connector
Applicable wire size		0.3mm ² (AWG22)

3. DESIGN

3.1 System Designing Procedure

System designing procedure is shown below.

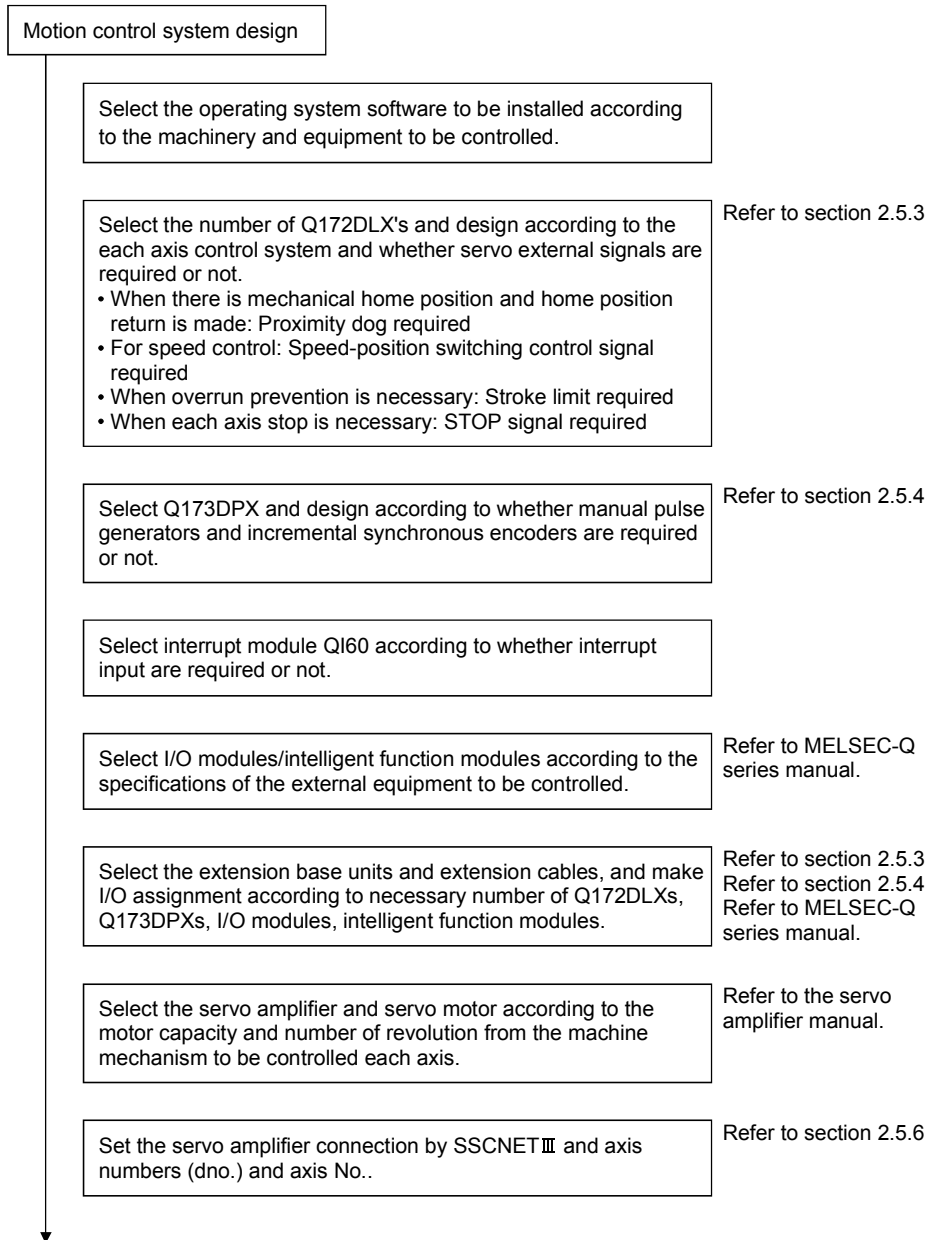

3 DESIGN

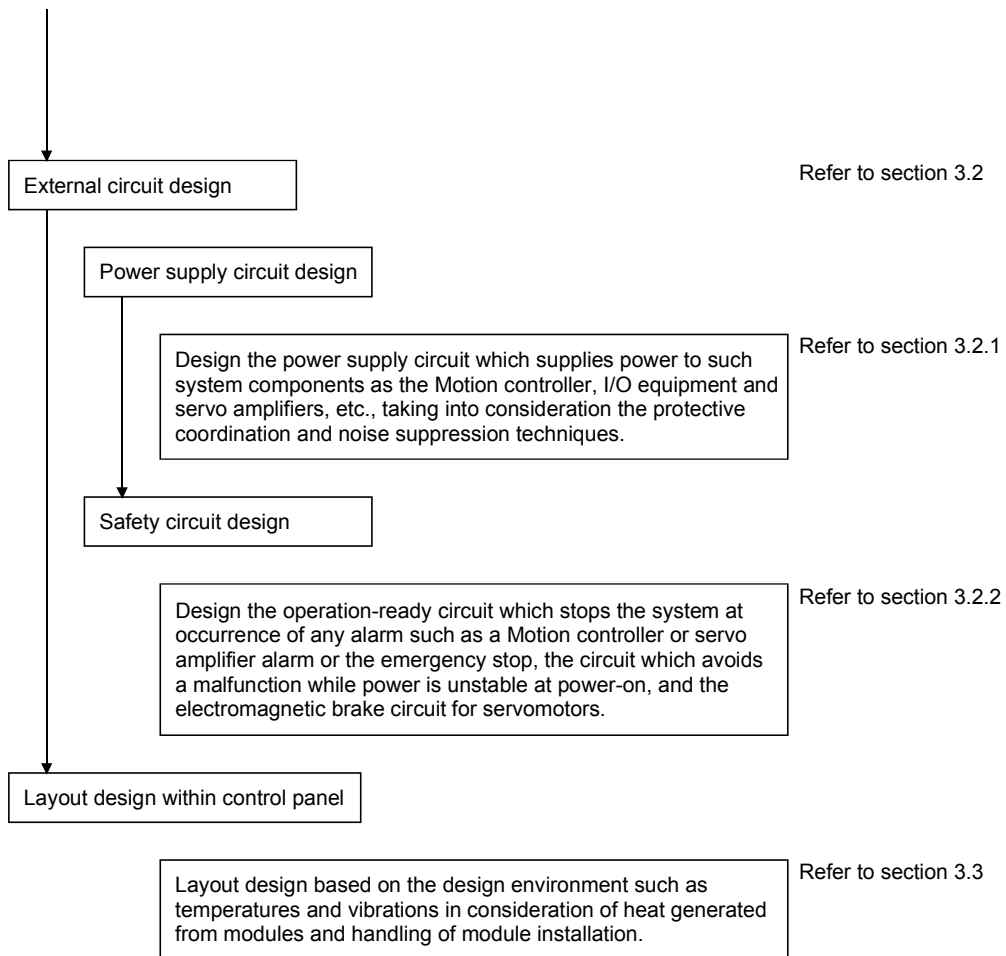

CAUTION

- Provide appropriate circuits external to the Motion controller to prevent cases where danger may result from abnormal operation of the overall system in the event of an external power supply fault or Motion controller failure.
- Mount the Motion controller, servo amplifier, servomotor and regenerative resistor on incombustible. Mounting them directly or close to combustibles will lead to fire.
- If a fault occurs in the Motion controller or servo amplifier, shut the power OFF at the servo amplifier's power source. If a large current continues to flow, fire may occur.
- When using a regenerative resistor, shut the power OFF with an error signal. The regenerative resistor may abnormally overheat due to a fault in the regenerative transistor, etc., and may lead to fire.
- Always take heat measures such as flame proofing for the inside of the control panel where the servo amplifier or regenerative resistor is mounted and for the wires used. Failing to do so may lead to fire.
- Do not apply a voltage other than that specified in the instruction manual on any terminal. Doing so may lead to destruction or damage.
- Do not mistake the polarity (+ / -), as this may lead to destruction or damage.

CAUTION

- Do not touch the heat radiating fins of controller or servo amplifier, regenerative resistor and servomotor, etc. while the power is ON and for a short time after the power is turned OFF. In this timing, these parts become very hot and may lead to burns.
- Always turn the power OFF before touching the servomotor shaft or coupled machines, as these parts may lead to injuries.
- Do not go near the machine during test operations or during operations such as teaching. Doing so may lead to injuries.
- Always mount a leakage breaker on the Motion controller and servo amplifier power source.
- If mounting of an electromagnetic contactor for power shut off during an error, etc., is specified in the instruction manual for the servo amplifier, etc., always mount the electromagnetic contactor.
- Mount an emergency stop circuit externally so that the operation can be stopped immediately and the power shut off.
- Use the Motion controller, servo amplifier, servomotor and regenerative resistor with the correct combinations listed in the instruction manual. Other combinations may lead to fire or faults.
- If safety standards (ex., robot safety rules, etc.,) apply to the system using the Motion controller, servo amplifier and servomotor, make sure that the safety standards are satisfied.
- Construct a safety circuit externally of the Motion controller or servo amplifier if the abnormal operation of the Motion controller or servo amplifier differ from the safety directive operation in the system.
- In systems where coasting of the servomotor will be a problem during the forced stop, the emergency stop, servo OFF or when the power is shut OFF, use dynamic brakes.
- Make sure that the system considers the coasting amount even when using dynamic brakes.
- In systems where perpendicular shaft dropping may be a problem during the forced stop, the emergency stop, servo OFF or when the power is shut OFF, use both dynamic brakes and electromagnetic brakes.
- The dynamic brakes must be used only during the forced stop, the emergency stop and errors where servo OFF occurs. These brakes must not be used for normal braking.
- The brakes (electromagnetic brakes) assembled into the servomotor are for holding applications, and must not be used for normal braking.
- The system must have a mechanical allowance so that the machine itself can stop even if the stroke limits switch is passed through at the max. speed.
- Use wires and cables that have a wire diameter, heat resistance and bending resistance compatible with the system.
- Use wires and cables within the length of the range described in the instruction manual.
- The ratings and characteristics of the parts (other than Motion controller, servo amplifier, servomotor) used in a system must be compatible with the Motion controller, servo amplifier and servomotor.
- Install a cover on the shaft so that the rotary parts of the servomotor are not touched during operation.
- There may be some cases where holding by the electromagnetic brakes is not possible due to the life or mechanical structure (when the ball screw and servomotor are connected with a timing belt, etc.). Mount a stopping device to ensure safety on the machine side.

3 DESIGN

3.2 External Circuit Design

As to the ways to design the external circuits of the Motion system, this section explains the method and instructions for designing the power supply circuits and safety circuits, etc.

(1) Sample system circuit design for Motion CPU area

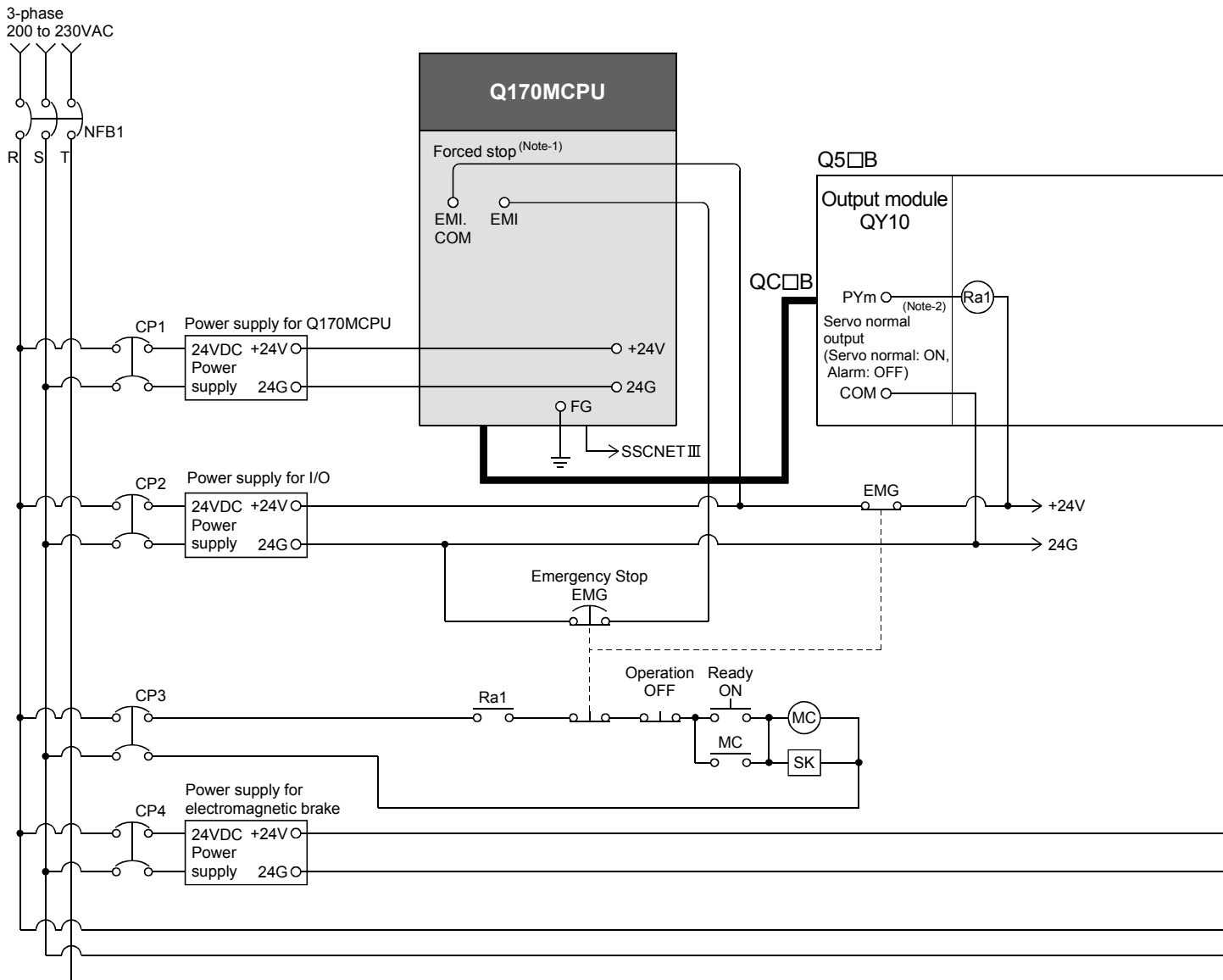

3 DESIGN

POINT

- (1) (Note-1) : Make the forced stop input cable within 30m(98.43ft.).
The forced stop by the forced stop terminal of input module is also possible.
- (2) (Note-2) : Motion SFC program example is shown in the right record.
- (3) (Note-3) : It is also possible to use a full wave rectified power supply as the power supply for the electromagnetic brake.
- (4) (Note-4) : It is also possible to use forced stop signal of the servo amplifier.
- (5) (Note-5) : It recommends using one leakage breaker for one servo amplifier.
When electric power is supplied to multiple servo amplifiers for one leakage breaker, select the wire connected to the servo amplifier according to the capacity of the leakage breaker.

<Example> For control axis 1 and axis 2

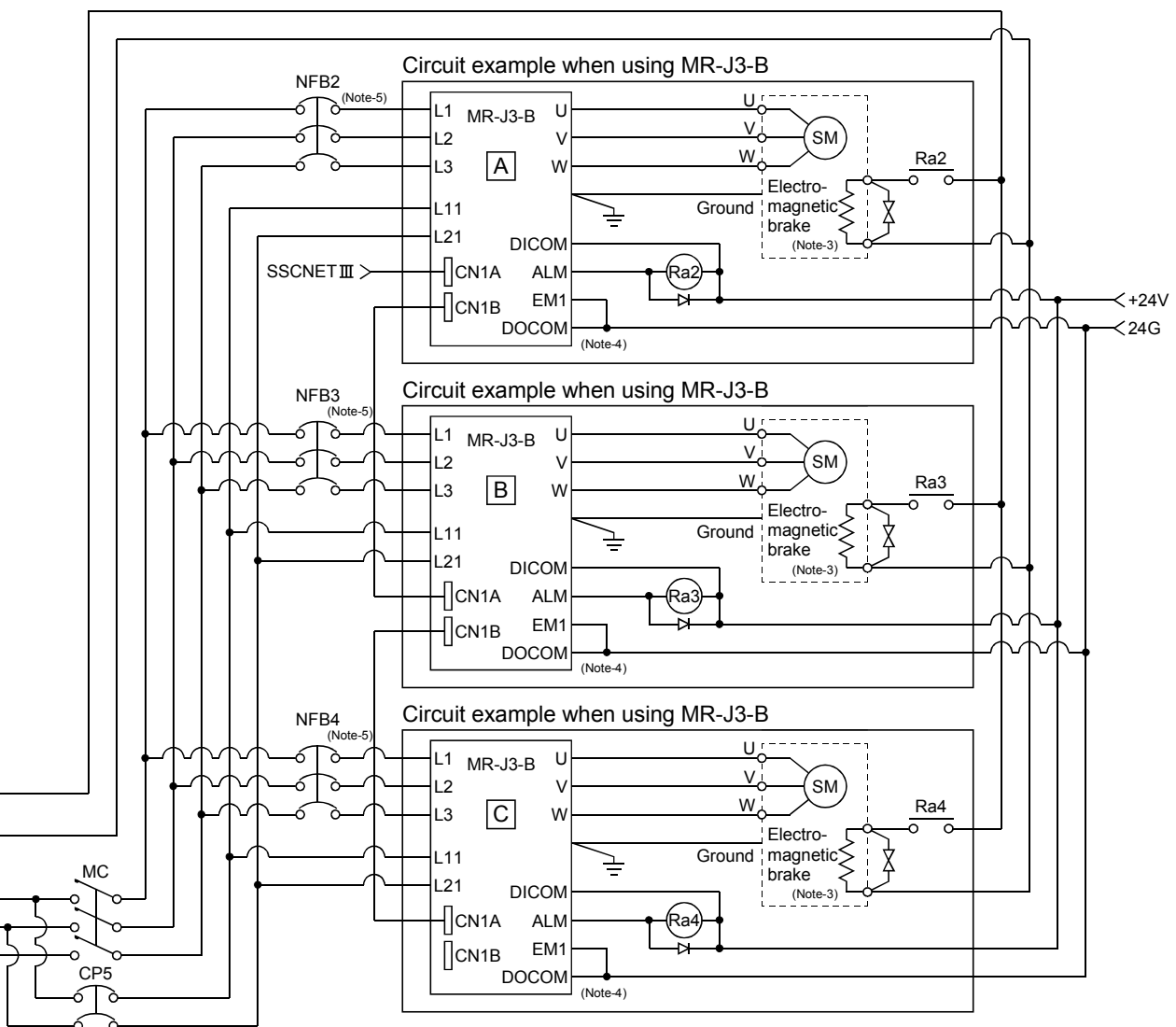
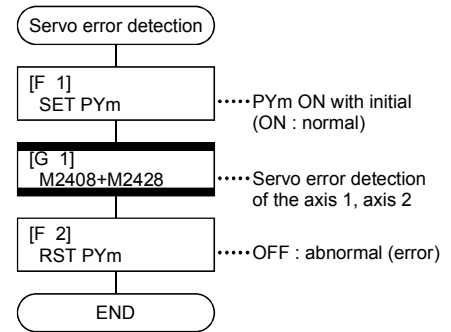

(Note-1) : When the control power supply of servo amplifier is shut off, it is not possible to communicate with the servo amplifier after that.
Example) When the control power supply L11/L21 of servo amplifier in above B figure is shut off, it is also not possible to communicate with the servo amplifier C.

If only a specific servo amplifier power supply is shut off, be sure to shut off the main circuit power supply L1/L2/L3, and do not shut off the control power supply L11/L21.

(Note-2) : Be sure to shut off the both of main circuit power supply L1/L2/L3 and control power supply L11/L21 at the time of exchange of servo amplifier. At this time, it is not possible to communicate between the servo amplifier and Motion controller. Therefore, be sure to exchange the servo amplifier after stopping the operating of machine beforehand.

(2) System design circuit example of the PLC CPU area

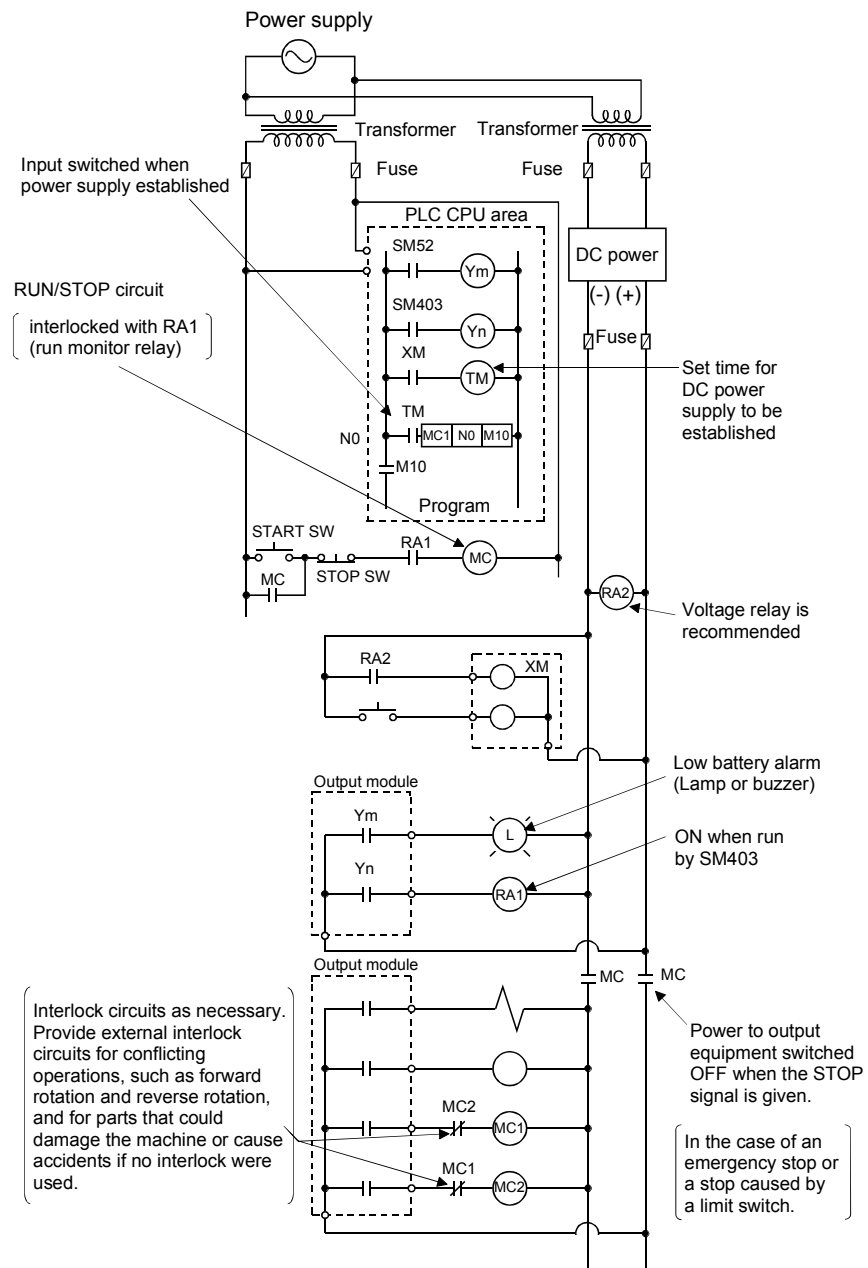

The start-up procedure is as follows

- 1) Switch the Motion controller power ON.
- 2) Set the Motion controller to RUN.
- 3) When DC power is established, RA2 goes ON.
- 4) Timer (TM) times out after the DC power reaches 100[%]. (The TM set value should be the period of time from when RA2 goes ON to the establishment of 100[%] DC voltage. Set this value to approximately 0.5 seconds.)
- 5) Turn ON the start switch.
- 6) When the electromagnetic contactor (MC) comes on, the output equipment is powered and may be driven by the program. (If a voltage relay is used at RA2, no timer (TM) is required in the program.)

3.2.1 Power supply circuit design

This section describes the protective coordination and noise suppression techniques of the power supply circuit.

(1) Separation and protective coordination (leakage current protection, over current protection) of power supply lines

Separate the lines for Motion controller's power supplies from the lines for I/O devices and servo amplifiers as shown below.

When there is much noise, connect an insulation transformer.

The Motion controller may malfunction as it is affected by various noises such as electric path noises from the power supply systems, and electromagnetic noises from conductors. To avoid such troubles, set the 24VDC power supply according to application.

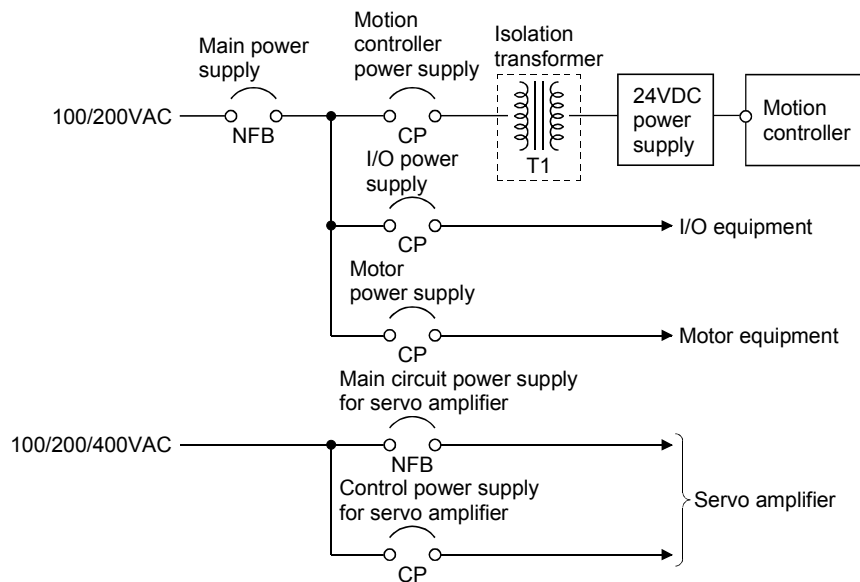

(2) Grounding

The Motion controller may malfunction as it is affected by various noises such as electric path noises from the power supply systems, radiated and induced noises from other equipment, servo amplifiers and their cables, and electromagnetic noises from conductors. To avoid such troubles, connect the earthing ground of each equipment and the shield grounds of the shielded cables to the earth. For grounding, use the exclusive ground terminal wire of each equipment or a single-point earth method to avoid grounding by common wiring, where possible, since noises may sneak from other equipment due to common impedances.

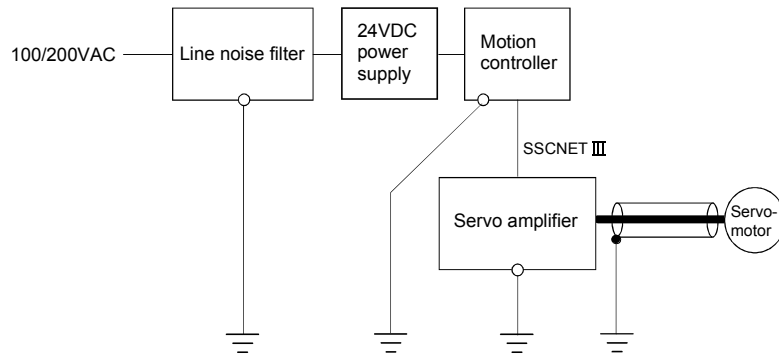

(Note): Be sure to ground the line noise filter, Motion controller, servo amplifier and servomotor. (Ground resistance : 100 Ω or less)

3.2.2 Safety circuit design

(1) Concept of safety circuits

When the Motion controller is powered on and off, normal control output may not be done momentarily due to a delay or a startup time difference between the Motion controller power supply and the external power supply (DC in particular) for the control target.

Also, an abnormal operation may be performed if an external power supply fault or Motion controller failure takes place.

To prevent any of these abnormal operations from leading to the abnormal operation of the whole system and in a fail-safe viewpoint, areas which can result in machine breakdown and accidents due to abnormal operations (e.g. emergency stop, protective and interlock circuits) should be constructed outside the Motion controller.

(2) Emergency stop circuit

The circuit should be constructed outside of the Motion controller or servo amplifier. Shut off the power supply to the external servo amplifier by this circuit, make the electromagnetic brakes of the servomotor operated.

(3) Forced stop circuit

(a) The forced stop of all servo amplifiers is possible in a lump by using the forced stop input of Motion controller. After forced stop, the forced stop factor is removed and the forced stop canceled.

(The servo error detection signal does not turn on with the forced stop.)

The forced stop input cannot be invalidated in the parameter setting of system setting.

Make the forced stop input cable within 30[m](98.43[ft.]).

The wiring example for the forced stop input of Motion controller is shown below.

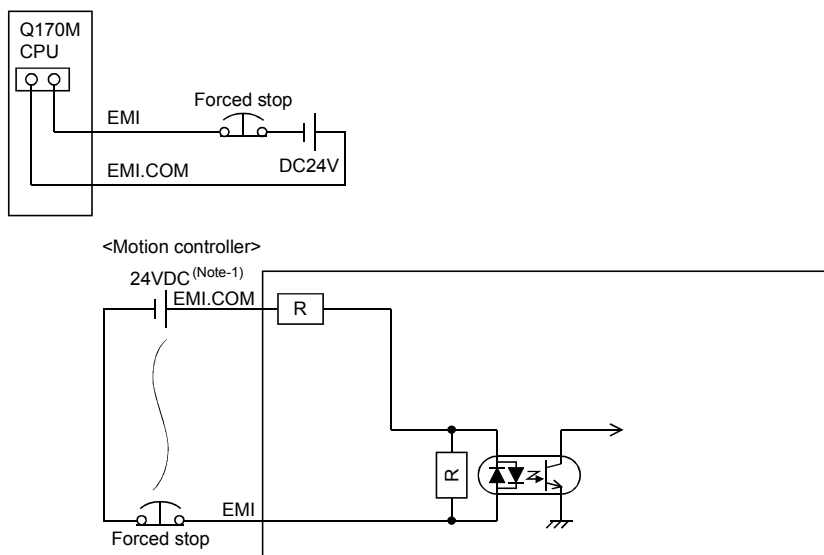

(Note): The forced stop input can not be invalidated in the system settings.

(Note-1): As for the connection, both "+" and "-" are possible.

(b) The forced stop of all servo amplifiers is possible in a lump by using the forced stop input of input modules. After forced stop, the forced stop factor is removed and the forced stop canceled.

(The servo error detection signal does not turn on with the forced stop.)

The forced stop input can be set by allocation of the device number in the parameter setting of system setting. When the device is used, apply 24VDC voltage on EMI terminal and invalidate the forced stop input of EMI terminal.

The wiring example that uses the forced stop input of input module (QX10) is shown below.

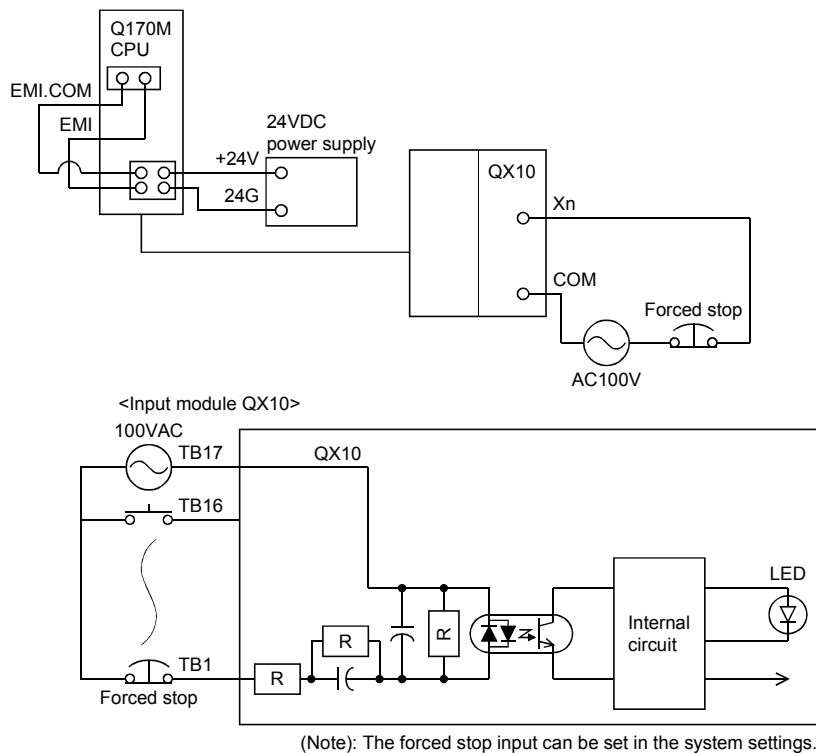

(c) It is also possible to use the forced stop signal of the servo amplifier. Refer to manual of the servo amplifier about servomotor capacity.

Operation status of the emergency stop and the forced stop are as follows.

Item	Operation of the signal ON	Remark
Emergency stop	Servo OFF	Shut off the power supply to the external servo amplifier by external circuit, make the servomotor stopped.
Forced stop		The servomotor is stopped according to the stop instruction from Motion controller to the servo amplifier.

3.3 Layout Design within The Control Panel

3.3.1 Mounting environment

Mount the Motion controller system in the following environment conditions.

- (1) Ambient temperature is within the range of 0 to 55[°C] (32 to 131[°F]).
- (2) Ambient humidity is within the range of 5 to 95[%]RH.
- (3) No condensing from sudden temperature changes
- (4) No corrosive or inflammable gas
- (5) There must not be a lot of conductible dust, iron filings, oil mist, or salt, organic solvents.
- (6) No direct sunlight
- (7) No strong electrical or magnetic fields
- (8) No direct vibrations or shocks on the Motion controller

3.3.2 Calculating heat generation by Motion controller

The ambient temperature inside the panel storing the Motion controller must be suppressed to an ambient temperature of 55°C(131°F) or less, which is specified for the Motion controller.

For the design of a heat releasing panel, it is necessary to know the average power consumption (heating value) of the devices and instruments stored inside.

Here the method of obtaining the average power consumption of system is described. From the power consumption, calculate a rise in ambient temperature inside the control panel.

How to calculate average power consumption

The power consuming parts of the Motion controller are roughly classified into six blocks as shown below.

(1) Total power consumption for logic 5VDC circuits of all modules (including Motion controller)

This is a power to which each module consumes the current supplied by the 5VDC output circuit of the internal power supply.

(including the current consumption of the base unit.)

$$W_{5V} = I_{5V} \times 5 \text{ [W]}$$

I_{5V} : Current consumption of logic 5VDC circuit of each module

(2) Power consumption of internal power supply

The power conversion efficiency of the internal power supply is approx. 80[%], while 20 [%] of the output power is consumed as heat. As a result, 1/4 of the output power is the power consumption.

Therefore the calculation formula is as follows.

$$W_{PW} = \frac{1}{4} \times W_{5V} \text{ [W]}$$

I_{5V} : Current consumption of logic 5VDC circuit of each module

(3) A total of 24VDC average power consumption of the output module

The average power of the external 24VDC power is the total power consumption of each output module.

$$W_{24V} = I_{24V} \times 24 \times \text{Simultaneous ON rate [W]}$$

I_{24V} : Average current consumption of external 24VDC power supply [A]

(Power consumption for simultaneous ON points)

(4) Average power consumption due to voltage drop in the output section of the output module

(Power consumption for simultaneous ON points)

$$W_{OUT} = I_{OUT} \times V_{drop} \times \text{Number of outputs} \times \text{Simultaneous ON rate [W]}$$

I_{OUT} : Output current (Current in actual use) [A]

V_{drop} : Voltage drop in each output module [V]

- (5) Average power consumption of the input section of the input module (Power consumption for simultaneous ON points)

$$W_{IN} = I_{IN} \times E \times \text{Number of input points} \times \text{Simultaneous ON rate [W]}$$

I_{IN} : Input current (Effective value for AC) [A]

E : Input voltage (Voltage in actual use) [V]

- (6) Power consumption of the external power supply section of the intelligent function module

$$W_S = I_{+15V} \times 15 + I_{-15V} \times 15 + I_{24V} \times 24[W]$$

I_{+15V} : Power consumption of the +15VDC external power supply section of the intelligent function module

I_{-15V} : Power consumption of the -15VDC external power supply section of the intelligent function module

I_{24V} : Power consumption of the 24VDC external power supply section of the intelligent function module

The total of the power consumption values calculated for each block is the power consumption of the overall Motion system

$$W = W_{5V} + W_{PW} + W_{24V} + W_{OUT} + W_{IN} + W_S [W]$$

From this overall power consumption [W], calculate the heating value and a rise in ambient temperature inside the panel.

The outline of the calculation formula for a rise in ambient temperature inside the panel is shown below.

$$T = \frac{W}{UA} [^{\circ}C]$$

W : Power consumption of overall Motion system (value obtained above)

A : Surface area inside the panel [m^2]

U : When the ambient temperature inside the panel is uniformed by a fan 6

When air inside the panel is not circulated 4

POINT
<p>If the temperature inside the panel has exceeded the specified range, it is recommended to mount a heat exchanger to the panel to lower the temperature. If a normal ventilating fan is used, dust will be sucked into the Motion controller together with the external air, and it may affect the performance of the Motion controller.</p>

(7) Example of average power consumption calculation

(a) System configuration

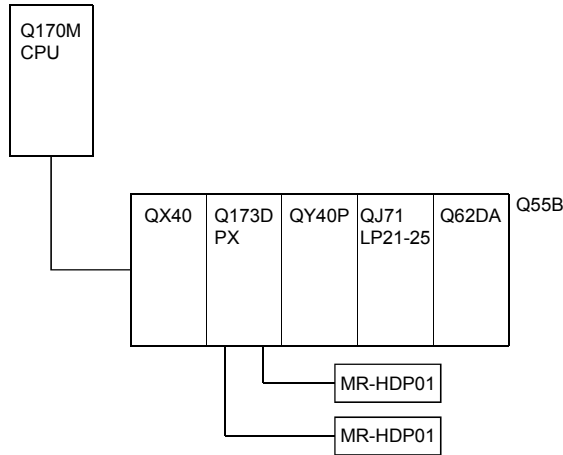

(b) 5VDC/24VDC current consumption of each module

Model name	5VDC	24VDC
Q170M CPU	2.00 [A]	—
QX40 ^(Note)	0.05 [A]	—
Q173DPX	0.38 [A]	—
MR-HDP01	0.06 [A]	—
QY40P ^(Note)	0.065 [A]	1.60 [A]
QJ71LP21-25 ^(Note)	0.55 [A]	—
Q62DA ^(Note)	0.33 [A]	0.12 [A]
Q55B ^(Note)	0.10 [A]	—

(Note) : 5VDC internal current consumption of shared equipments with PLC might be changed. Be sure to refer to the MELSEC-Q series PLC Manuals.

(c) Total power consumption for logic 5VDC circuits of all modules

$$W_{5v} = (2.00 + 0.05 + 0.38 + 0.06 \times 2 + 0.065 + 0.55 + 0.33 + 0.10) \times 5 = 17.975 \text{ [W]}$$

(d) Power consumption of internal power supply

$$W_{PW} = \frac{1}{4} \times 17.975 = 4.494 \text{ [W]}$$

(e) A total of 24VDC average power consumption of the output module

$$W_{24v} = 1.60 \times 24 \times 1 = 38.4 \text{ [W]}$$

(f) Average power consumption due to voltage drop in the output section of the output module

$$W_{OUT} = 0.1 \times 0.2 \times 16 \times 1 = 0.32 \text{ [W]}$$

(g) Average power consumption of the input section of the input module

$$W_{IN} = 0.004 \times 24 \times 16 \times 1 = 1.536 \text{ [W]}$$

- (h) Power consumption of the external power supply section of the intelligent function module.

$$W_s = 0.12 \times 24 = 2.88 \text{ [W]}$$

- (i) Power consumption of overall system

$$W = 17.975 + 4.494 + 38.4 + 0.32 + 1.536 + 2.88 = 65.605 \text{ [W]}$$

3 DESIGN

3.4 Design Checklist

At the worksite, copy the following table for use as a check sheet.

Item	Sub Item	Design confirmation		Check	
Module selection	Motion controller selection	Number of axes	axes	<input type="checkbox"/>	
	Motion module selection	Manual pulse generator		pcs.	<input type="checkbox"/>
		Incremental synchronous encoder		pcs.	<input type="checkbox"/>
		Upper limit point		points	<input type="checkbox"/>
		Lower limit point		points	<input type="checkbox"/>
		STOP input point		points	<input type="checkbox"/>
		Proximity dog input point		points	<input type="checkbox"/>
		Speed switching input point		points	<input type="checkbox"/>
		Tracking enable signal point		points	<input type="checkbox"/>
		Q172DLX		modules	<input type="checkbox"/>
		Q173DPX		modules	<input type="checkbox"/>
	Extension base unit and extension cable selection	Number of I/O modules/intelligent function modules installed to extension base		modules	<input type="checkbox"/>
		Distance between Motion controller and extension base		mm	<input type="checkbox"/>
		Extension base unit selection			<input type="checkbox"/>
Extension cable selection			<input type="checkbox"/>		
External circuit design	Fail-safe circuit design	Avoidance of operation failure at power-on		<input type="checkbox"/>	
		Avoidance of hazard at Motion controller failure		<input type="checkbox"/>	
Layout design	Module layout design	Conformance with general specifications such as ambient temperature, humidity, dust, etc.		<input type="checkbox"/>	
		Total power consumption of base unit (Calculate the heating value)	W	<input type="checkbox"/>	
		Layout in consideration of clearances between enclosure's inside walls, other structures and modules and heats generated by modules within the control panel.			<input type="checkbox"/>

4. INSTALLATION AND WIRING

4.1 Module Installation

4.1.1 Instructions for handling

CAUTION

- Use the Motion controller in an environment that meets the general specifications contained in this manual. Using this Motion controller in an environment outside the range of the general specifications could result in electric shock, fire, operation failure, and damage to or deterioration of the product.
- When the modules are installed to the base unit while pressing the installation lever located at the bottom of module, insert the module fixing projection into the fixing hole in the base unit until it stops. Then, securely install the module with the fixing hole as a supporting point. Incorrect installation of the module can cause an operation failure, damage or drop.
When using the Motion controller in the environment of much vibration, tighten the module with a screw. Tighten the screw in the specified torque range. Under tightening may cause a drop, short circuit or operation failure. Over tightening may cause a drop, short circuit or operation failure due to damage to the screw or module.
- Be sure to connect the extension cable to connectors of the base unit correctly. After connecting, check them for looseness. Poor connections could cause an input or output failure.
- Completely turn off the externally supplied power used in the system before installation or removing the module. Not doing so could result in electric shock or damage to the product.
- Do not install/remove the module onto/from base unit or terminal block more than 50 times, after the first use of the product. Failure to do so may cause the module to malfunction due to poor contact of connector.
- Do not directly touch the module's conductive parts and electronic components. Doing so may cause an operation failure or give damage to the module.
- Lock the control panel and prevent access to those who are not certified to handle or install electric equipment.
- Do not touch the heat radiating fins of controller or servo amplifier's, regenerative resistor and servo motor, etc. while the power is ON and for a short time after the power is turned OFF. In this timing, these parts become very hot and may lead to burns.
Remove the modules while paying attention.

This section describes instructions for handling the Motion controller, motion, I/O and intelligent function modules, base units and so on.

- (1) Module, terminal block connectors and pin connectors are made of resin; do not drop them or subject them to strong impact.
- (2) Do not remove modules' printed circuit boards from the enclosure in order to avoid changes in operation.

4 INSTALLATION AND WIRING

- (3) Tighten the module fixing screws and terminal block screws within the tightening torque range specified below.

Location of screw	Tightening torque range [N•m]
Motion controller fixing screw (M5 screw)	2.75 to 3.63 ^(Note-1)
Motion controller FG fixing screw (M4 × 12 screw)	0.82 to 1.11
Module fixing screw (M3 × 12 screw)	0.36 to 0.48
I/O module terminal block screw (M3 screw)	0.42 to 0.58
I/O module terminal block fixing screw (M3.5 screw)	0.68 to 0.92
Base unit fixing screw (M4 × 14 screw)	1.40 to 1.89 ^(Note-1)

(Note-1): Torque range applies when the mounting panel is 2mm(0.88inch) thick and a fastening nut is used to secure the screw from the back side of the panel.

- (4) When using an extension cable, keep it away from the main circuit cable (high voltage and large current).
Keep a distance of 100mm or more from the main circuit.
- (5) Be sure to fix a Motion controller or base unit to the panel using mounting screws.
Not doing so could result in vibration that may cause erroneous operation.

4 INSTALLATION AND WIRING

4.1.2 Instructions for mounting the modules

When mounting the Motion controller, base unit to an enclosure or similar, fully consider its operability, maintainability and environmental resistance.

(1) Fitting dimensions

(a) Motion controller

[Unit: mm (inch)]

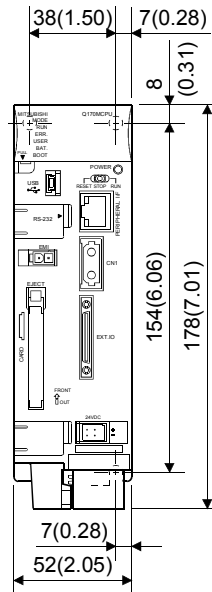

(b) Base unit

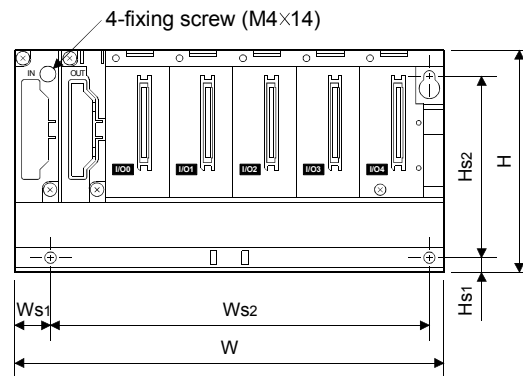

	Q52B	Q55B
W	106 (4.17)	189 (7.44)
Ws1	15.5 (0.61)	
Ws2	83.5 ± 0.3 (3.29 ± 0.01)	167 ± 0.3 (6.57 ± 0.01)
H	98 (3.86)	
Hs1	7 (0.28)	
Hs2	80 ± 0.3 (3.15 ± 0.01)	

[Unit: mm (inch)]

4 INSTALLATION AND WIRING

(2) Module mounting position

Keep the clearances shown below between the top/bottom faces of the module and other structures or parts to ensure good ventilation and facilitate module replacement.

(a) Motion controller

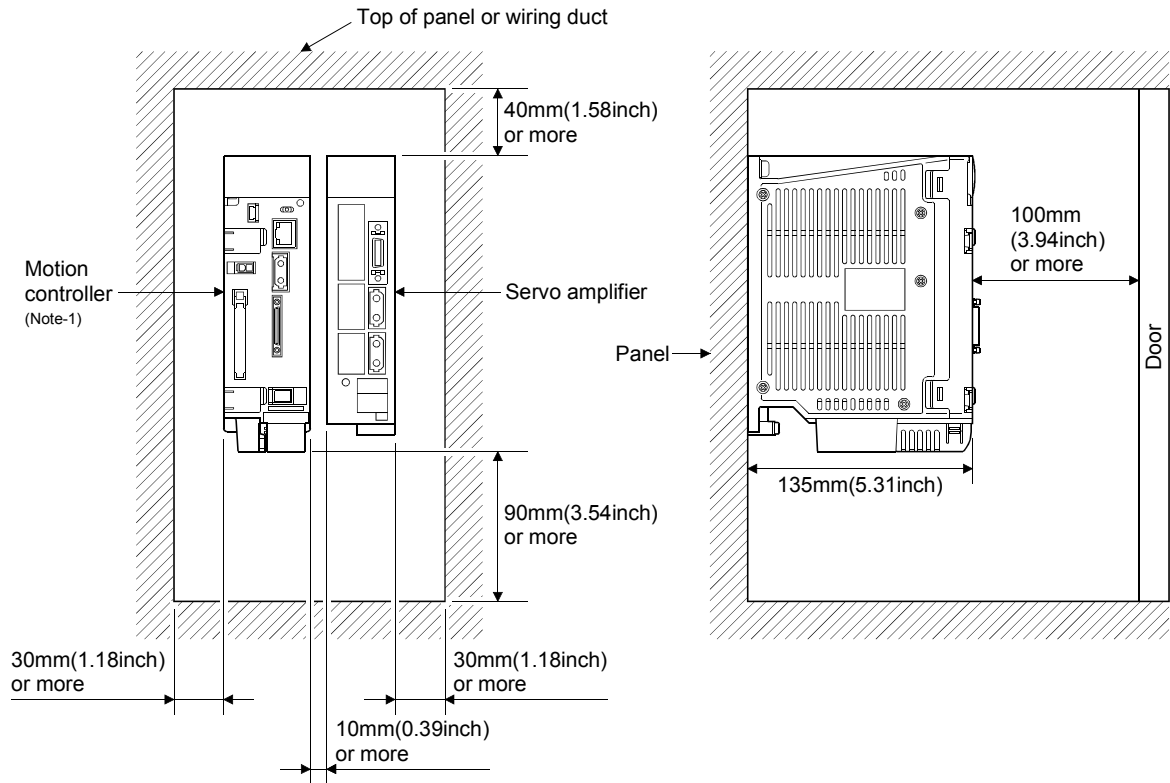

(Note-1) : Fit the Motion controller at the left side of the servo amplifier.

(b) Base unit

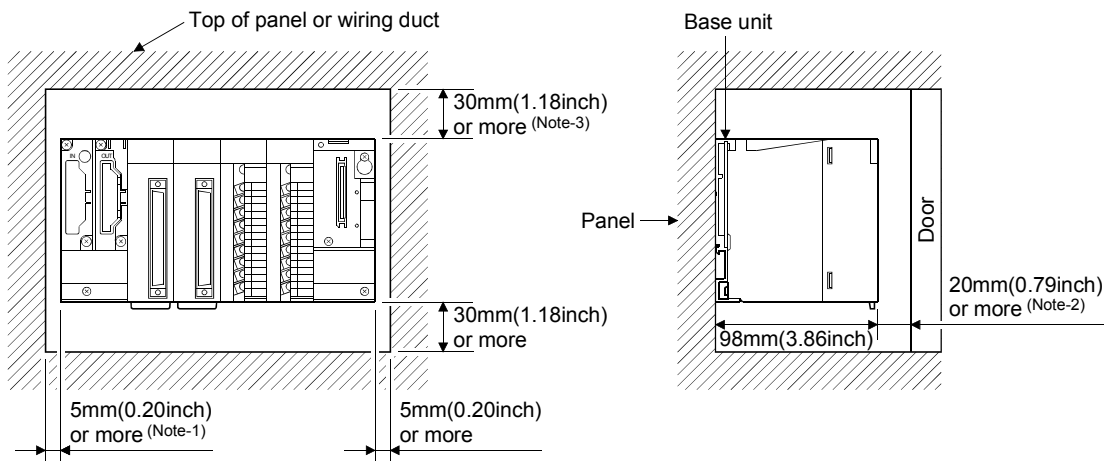

(Note-1) : 20mm(0.79inch) or more when the adjacent module is not removed and the extension cable is connected.

(Note-2) : 80mm(3.15inch) or more for the connector type.

(Note-3) : For wiring duct with 50mm(1.97inch) or less height. 40mm(1.57inch) or more for other cases.

(3) Module mounting orientation

- (a) Mount the Motion controller in the orientation shown below to ensure good ventilation for heat release.

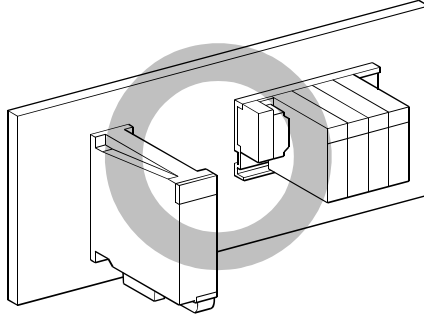

- (b) Do not use it in either of the orientations shown below.

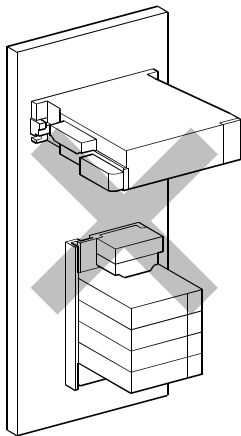

Vertical

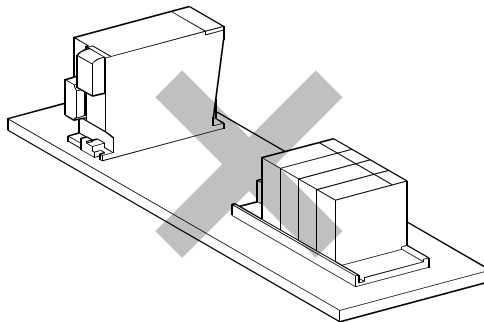

Flat

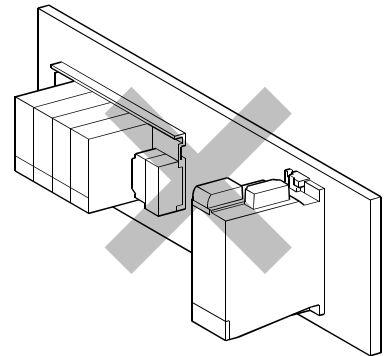

Upside down

(4) Mounting surface

Mount the Motion controller and base unit on a flat surface. If the mounting surface is not even, this may strain the printed circuit boards and cause malfunctions.

(5) Mounting of unit in an area where the other devices are mounted

Avoid mounting base unit in proximity to vibration sources such as large magnetic contractors and no-fuse circuit breakers; mount those on a separate panel or at a distance).

(6) Distances from the other devices

In order to avoid the effects of radiated noise and heat, provide the clearances indicated below between the Motion controller/base unit and devices that generate noise or heat (contactors and relays, etc.).

- In front of Motion controller/base unit: 100mm (3.94inch) or more
- On the right and left of Motion controller/base unit: 50mm (1.97inch) or more

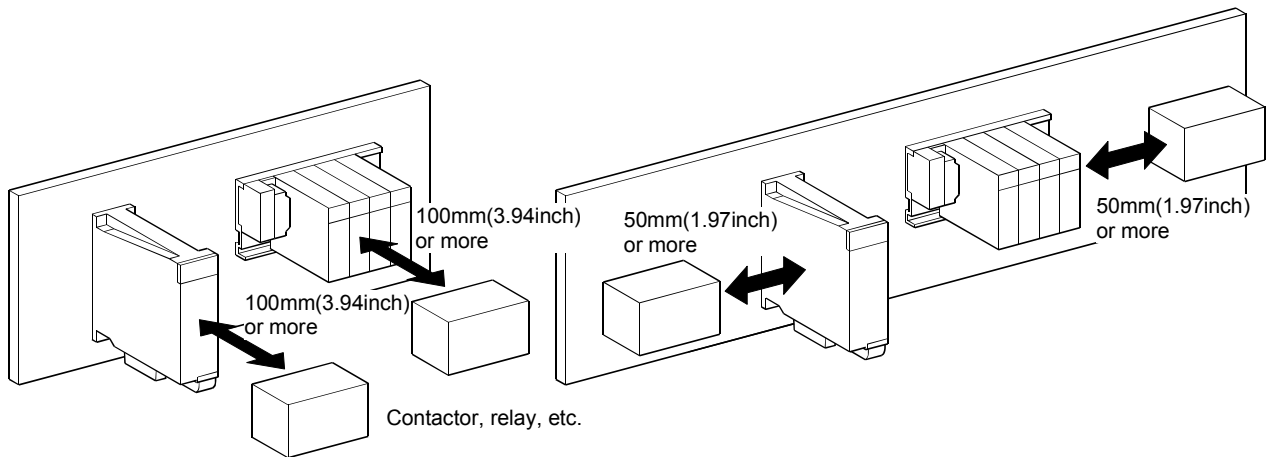

(7) Mounting method for the modules

(a) Motion controller

Mount a Motion controller in the following procedure.

- 1) Fit the one Motion controller bottom mounting screws into the enclosure.

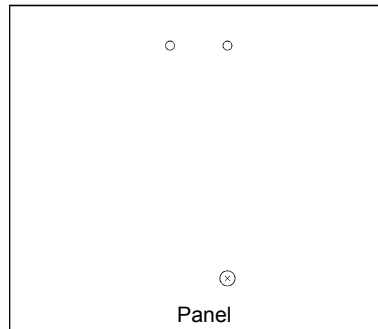

- 2) Place the bottom side notch of the Motion controller onto the bottom side screw.

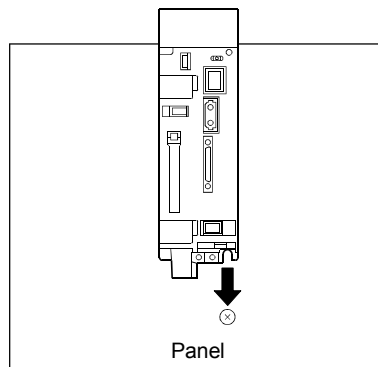

- 3) Fit the mounting screws into the holes at the top of the Motion controller and then retighten the all mounting screws.

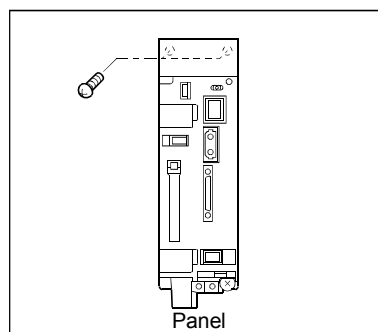

POINT

Screw the Motion controller to the panel.

⚠ CAUTION

- Do not touch the heat radiating fins of controller or servo amplifier's, regenerative resistor and servomotor, etc. while the power is ON and for a short time after the power is turned OFF. In this timing, these parts become very hot and may lead to burns. Remove the modules while paying attention.

(b) Base unit

Mount a base unit in the following procedure.

- 1) Fit the two base unit top mounting screws into the enclosure.

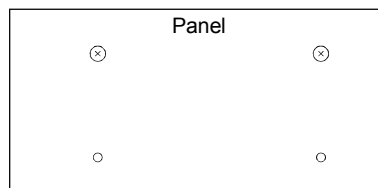

- 2) Place the right-hand side pear-shaped hole of the base unit onto the right-hand side screw.

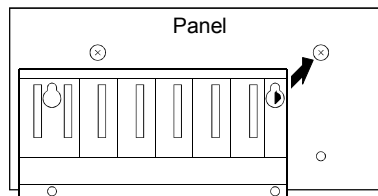

- 3) Place the left-hand side pear-shaped hole of the base unit onto the left-hand side screw.

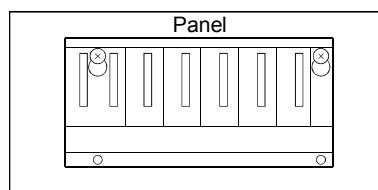

- 4) Fit the mounting screws into the holes at the bottom of the base unit, and then retighten the all mounting screws.

(Note): Mount a base unit to a panel, with no module installed in the right-end slot. Remove the base unit after removing the module from the right-end slot.

4 INSTALLATION AND WIRING

4.1.3 Installation and removal of module to the base unit

This section explains how to install and remove a Motion module, I/O module, intelligent function module or another module to and from the base unit.

(1) Installation and removal of the module from base unit

(a) Installation

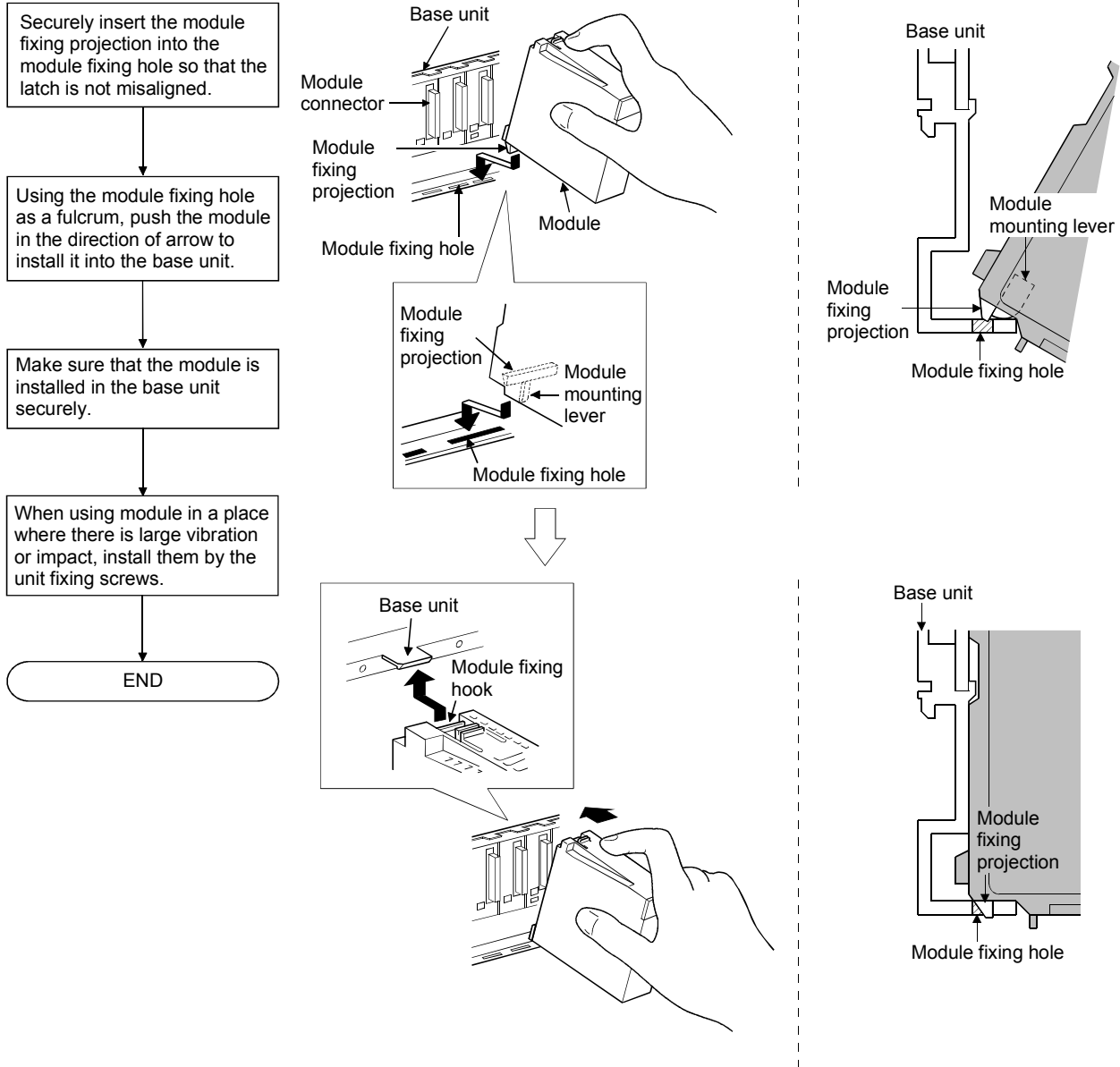

POINTS

- (1) When installing the module, always insert the module fixing projection into the module fixing hole of the base unit.
At that time, securely insert the module fixing projection so that it does not come off from the module fixing hole.
If the module is forcibly installed without the latch being inserted, the module connector and module will be damaged.
- (2) When using the modules in a place where there is large vibration or impact, screw the module to the base unit.
Module fixing screw : M3×12 (user-prepared)
- (3) Do not install/remove the module onto/from base unit or terminal block more than 50 times, after the first use of the product. Failure to do so may cause the module to malfunction due to poor contact of connector.

CAUTION

- When the modules are installed to the base unit while pressing the installation lever located at the bottom of module, insert the module fixing projection into the fixing hole in the base unit until it stops. Then, securely install the module with the fixing hole as a supporting point. Incorrect installation of the module can cause an operation failure, damage or drop.
When using the Motion controller in the environment of much vibration, tighten the module with a screw.
Tighten the screw in the specified torque range. Under tightening may cause a drop, short circuit or operation failure. Over tightening may cause a drop, short circuit or operation failure due to damage to the screw or module.

(b) Removal

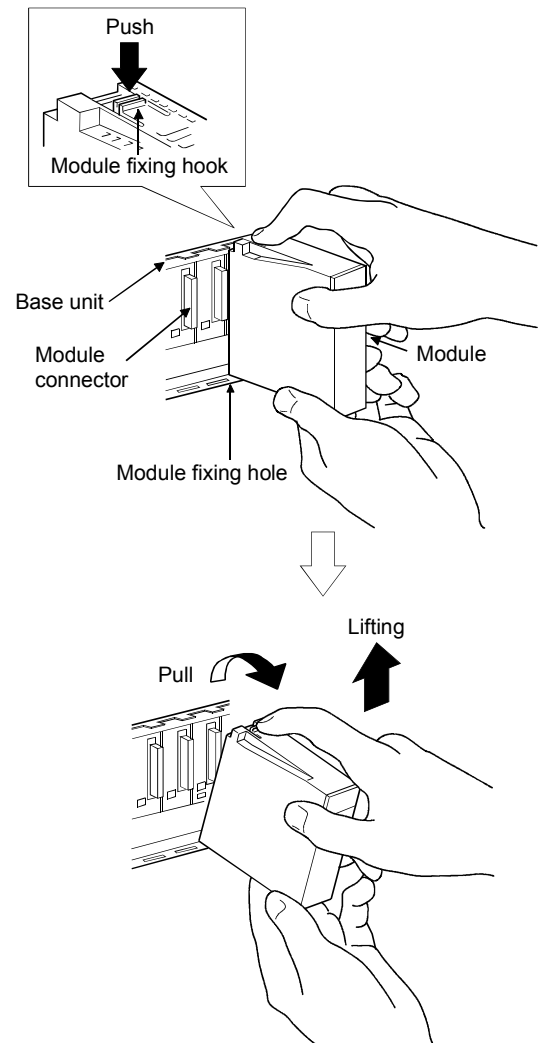
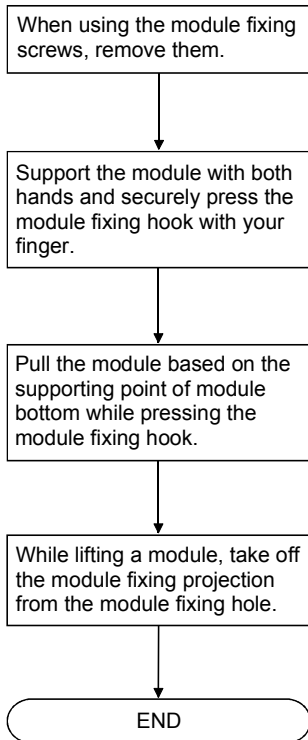

POINT

When the module fixing screw is used, always remove the module by removing the module fixing screw and then taking the module fixing projection off the module fixing hole of the base unit.

Attempting to remove the module by force may damage the module fixing projection.

4 INSTALLATION AND WIRING

4.1.4 Mounting and removal of the battery holder

Mounting and removal procedure of the battery holder to the Motion controller is shown below.

(1) Handling the battery lead wire

(a) Precautions for handling the battery lead wire

- For connection or removal of the battery lead wire, do it surely while holding a battery lead connector.

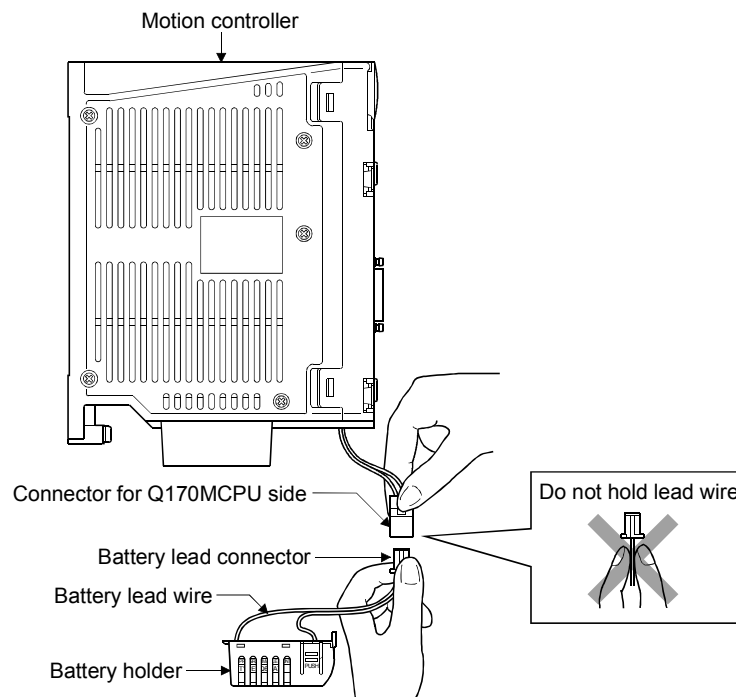

(b) Connection of the battery lead wire

- For connection of a battery (Q6BAT/Q7BAT) to the Motion controller, connect it surely to a battery connector of Motion controller side while holding a battery lead connector. Be sure to insert it until it clicks.

(c) Removal of the battery lead wire

- For removal of the battery lead wire, pull out it while holding a battery lead connector and a battery connector of Motion controller side.

POINT

- (1) Forcibly removal a connector while holding the battery lead wire will damage the battery connector or battery lead wire.
- (2) The data (Refer to Section 6.5) of RAM built-in Motion controller are backed up if the battery connector is not connect correctly.

4 INSTALLATION AND WIRING

(2) Battery holder (For Q6BAT)

(a) Mounting

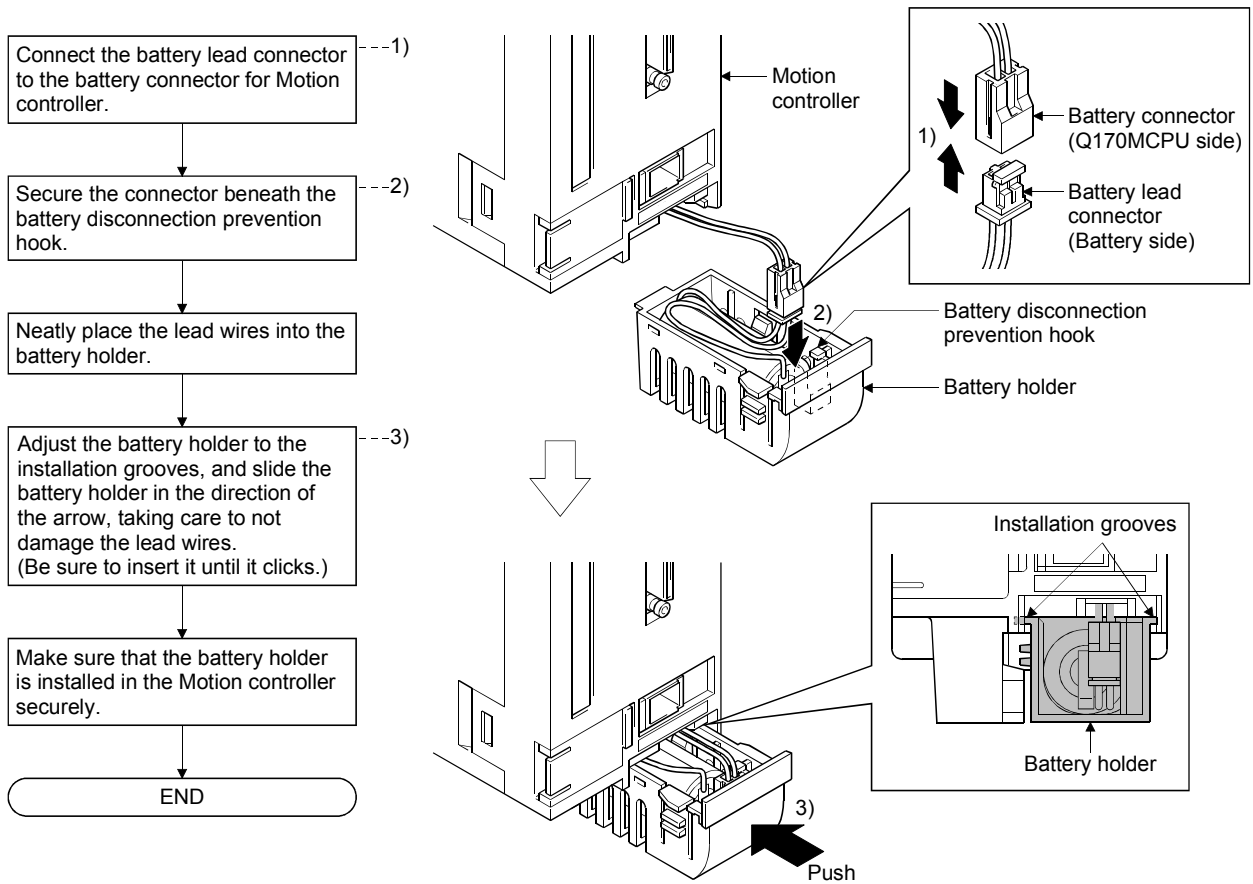

4 INSTALLATION AND WIRING

(b) Removal

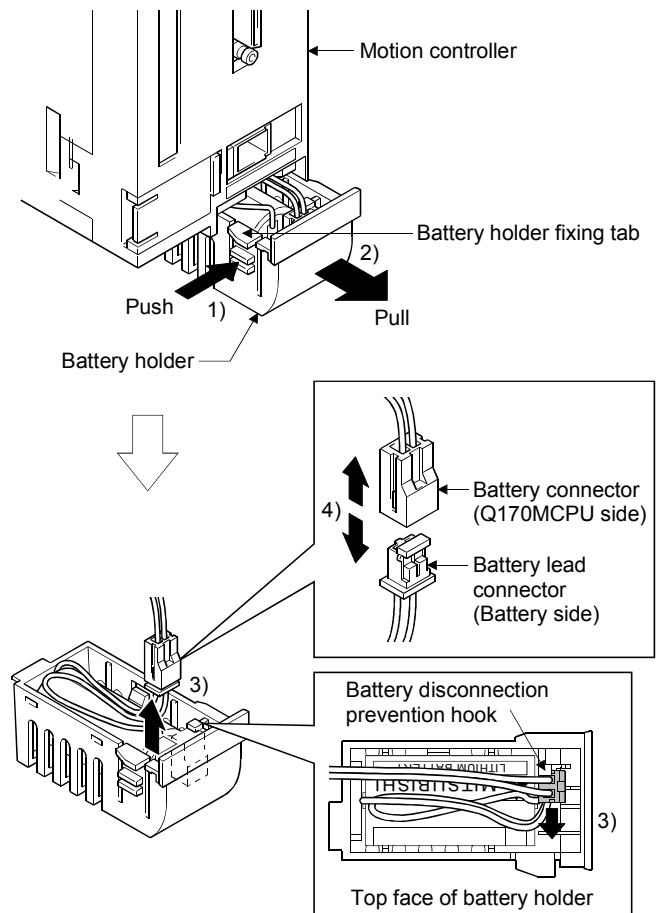
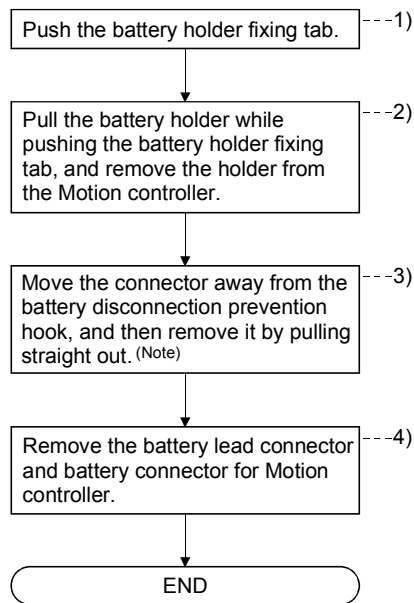

(Note): Do not pull on the lead wire forcibly to remove the connector.

(3) Battery holder (For Q7BAT)

(a) Mounting

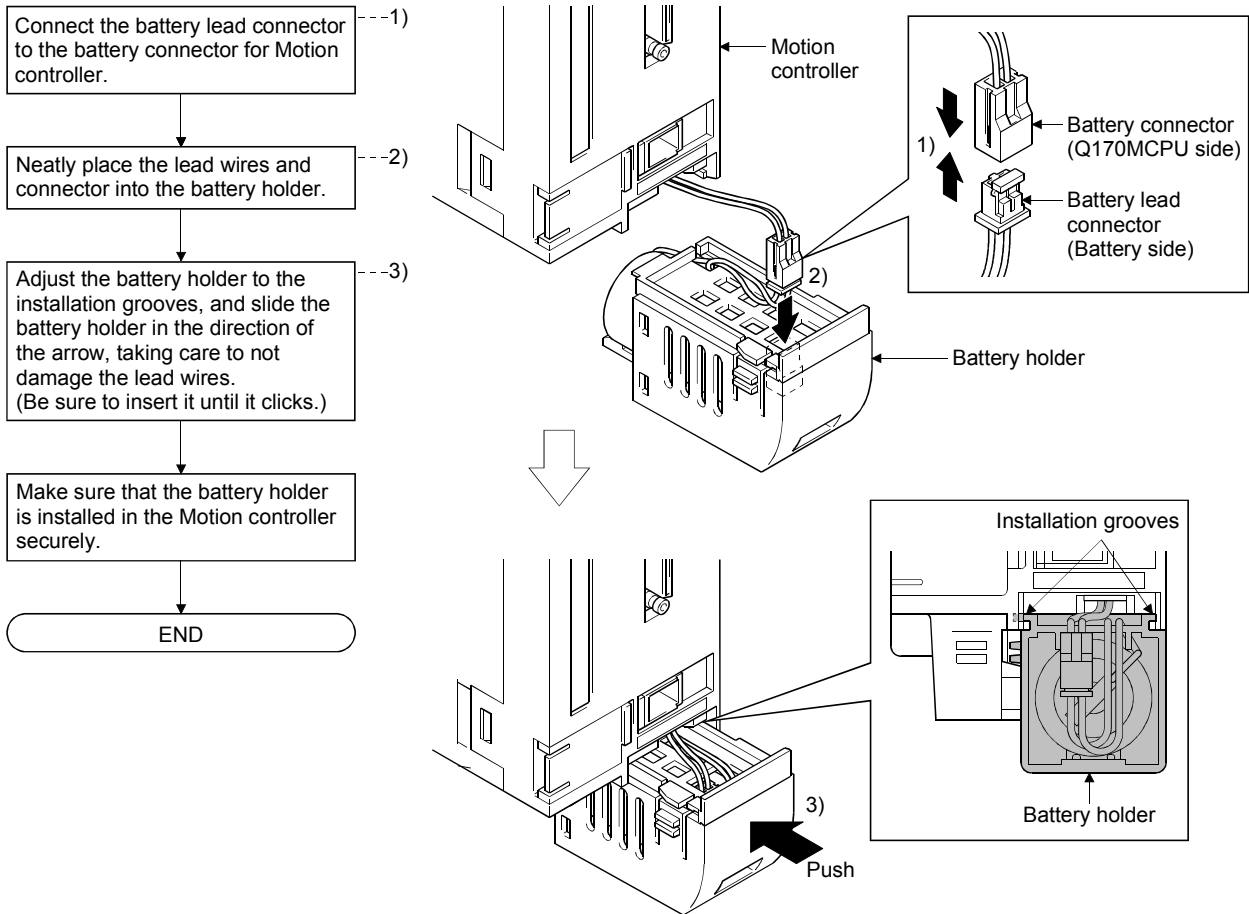

4 INSTALLATION AND WIRING

(b) Removal

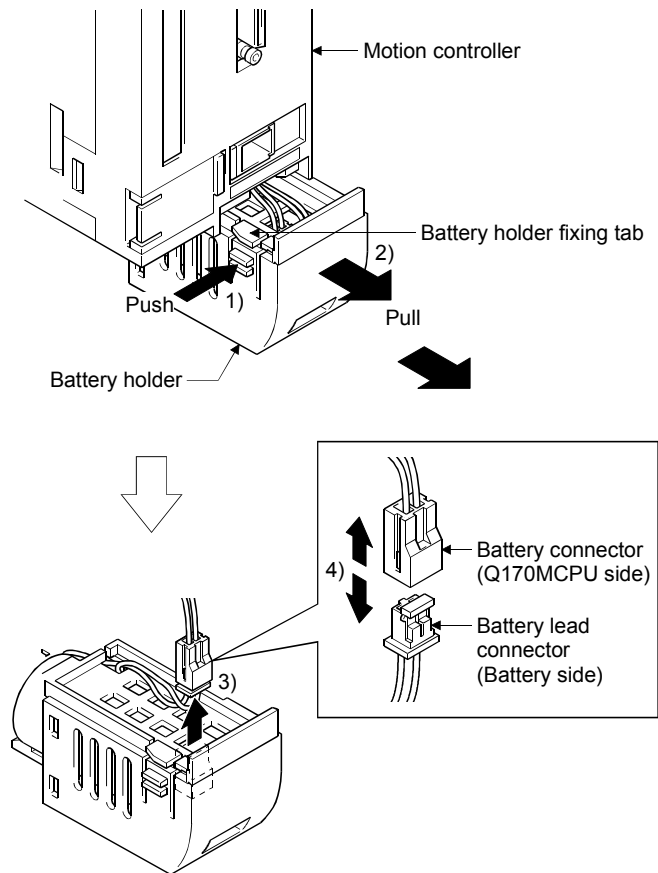
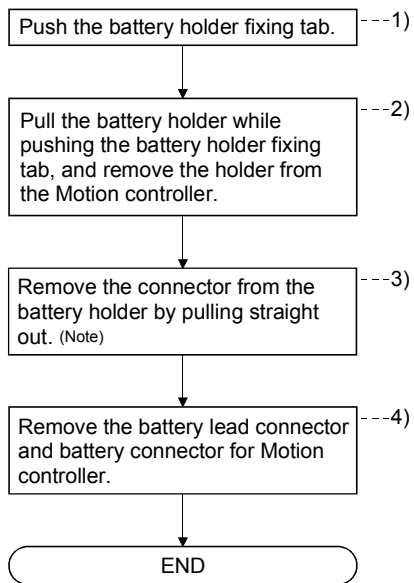

(Note): Do not pull on the lead wire forcibly to remove the connector.

4.2 Connection and disconnection of Cable

4.2.1 SSCNET III cable

(1) Precautions for handling the SSCNET III cable

- Do not stamp the SSCNET III cable.
- When laying the SSCNET III cable, be sure to secure the minimum cable bend radius or more. If the bend radius is less than the minimum cable bend radius, it may cause malfunctions due to characteristic deterioration, wire breakage, etc.
- For connection and disconnection of SSCNET III cable, hold surely a tab of cable connector.

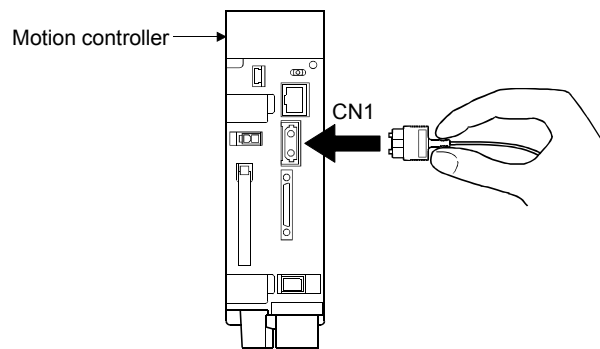

(2) Connection of SSCNET III cable

- For connection of SSCNET III cable to the Motion controller, connect it to the SSCNET III connector CN1 of Motion controller while holding a tab of SSCNET III cable connector. Be sure to insert it until it clicks.
- If the cord tip for the SSCNET III cable is dirty, optical transmission is interrupted and it may cause malfunctions. If it becomes dirty, wipe with a bonded textile, etc. Do not use solvent such as alcohol.

(3) Disconnection of SSCNET III cable

- For disconnection of SSCNET III cable, pull out it while holding a tab of SSCNET III cable connector or the connector.
- After disconnection of SSCNET III cable, be sure to put a cap (attached to Motion controller or servo amplifier) to the Motion controller and servo amplifier.
- For SSCNET III cable, attach the tube for protection optical cord's end face on the end of connector.

(4) Precautions of SSCNETⅢ cable wiring

SSCNETⅢ cable is made from optical fiber. If optical fiber is added a power such as a major shock, lateral pressure, haul, sudden bending or twist, its inside distorts or breaks, and optical transmission will not be available. Especially, as optical fiber for MR-J3BUS□M and MR-J3BUS□M-A is made of synthetic resin, it melts down if being left near the fire or high temperature. Therefore, do not make it touched the part, which becomes high temperature, such as radiator or regenerative option of servo amplifier, or servo motor.

Be sure to use optical fiber within the range of operating temperature described in this manual.

Read described item of this section carefully and handle it with caution.

(a) Minimum bend radius

Make sure to lay the cable with greater radius than the minimum bend radius. Do not press the cable to edges of equipment or others. For SSCNETⅢ cable, the appropriate length should be selected with due consideration for the dimensions and arrangement of Motion controller and servo amplifier. When closing the door of control panel, pay careful attention for avoiding the case that SSCNETⅢ cable is hold down by the door and the cable bend becomes smaller than the minimum bend radius.

Model name of SSCNETⅢ cable	Minimum bend radius[mm(inch)]
MR-J3BUS□M	25(0.98)
MR-J3BUS□M-A	Enforced covering cord : 50 (1.97) Cord : 25 (0.98)
MR-J3BUS□M-B	Enforced covering cord : 50 (1.97) Cord : 30 (1.18)

(b) Tension

If tension is added on the SSCNETⅢ cable, the increase of transmission loss occurs because of external force which concentrates on the fixing part of SSCNETⅢ cable or the connecting part of SSCNETⅢ connector. At worst, the breakage of SSCNETⅢ cable or damage of SSCNETⅢ connector may occur. For cable laying, handle without putting forced tension. (Refer to "APPENDIX 4.1 SSCNETⅢ cables" for the tension strength.)

(c) Lateral pressure

If lateral pressure is added on the SSCNETⅢ cable, the cable itself distorts, internal optical fiber gets stressed, and then transmission loss will increase. At worst, the breakage of SSCNETⅢ cable may occur. As the same condition also occurs at cable laying, do not tighten up SSCNETⅢ cable with a thing such as nylon band (TY-RAP).

Do not trample it down or tuck it down with the door of control panel or others.

4 INSTALLATION AND WIRING

(d) Twisting

If SSCNET III cable is twisted, it will become the same stress added condition as when local lateral pressure or bend is added. Consequently, transmission loss increases, and the breakage of SSCNET III cable may occur at worst.

(e) Disposal

When incinerating optical cable (cord) used for SSCNET III cable, hydrogen fluoride gas or hydrogen chloride gas which is corrosive and harmful may be generated. For disposal of SSCNET III cable, request for specialized industrial waste disposal services who has incineration facility for disposing hydrogen fluoride gas or hydrogen chloride gas.

(f) Wiring process of SSCNET III cable

Put the SSCNET III cable in the duct or fix the cable at the closest part to the Motion controller with bundle material in order to prevent SSCNET III cable from putting its own weight on SSCNET III connector.

Leave the following space for wiring.

• Putting in the duct

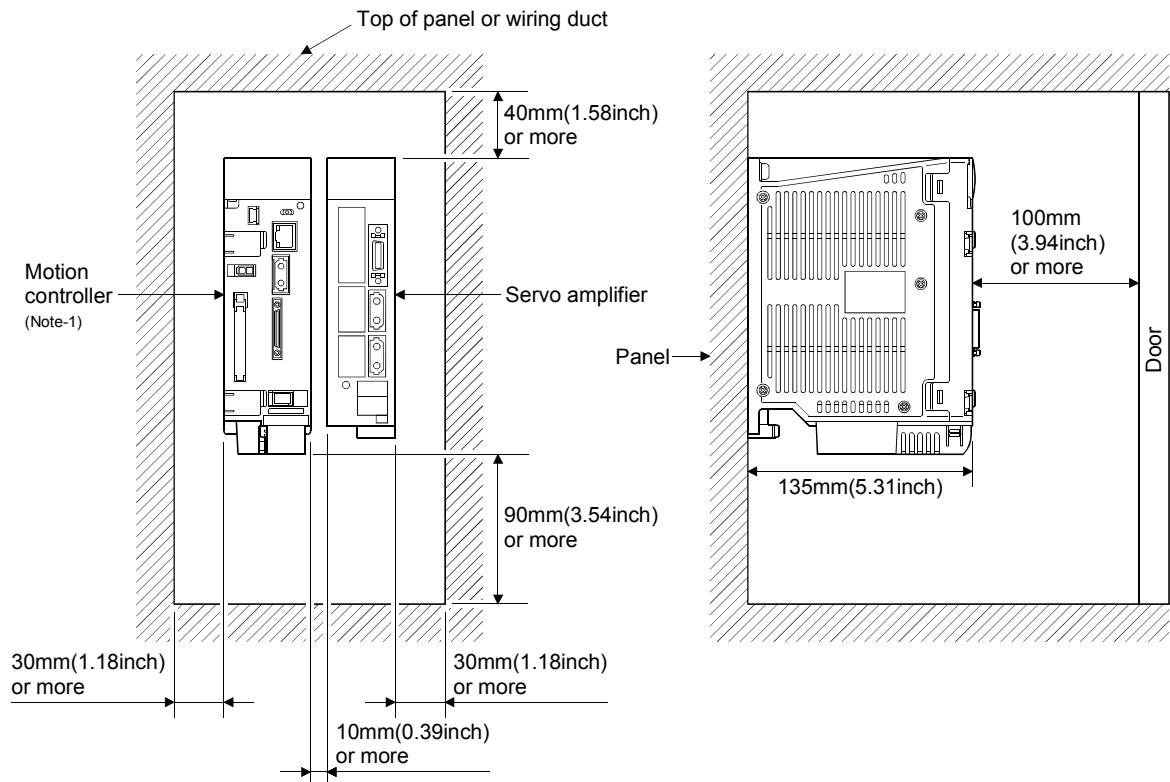

(Note-1) : Fit the Motion controller at the left side of the servo amplifier.

4 INSTALLATION AND WIRING

- Bundle fixing

Optical cord should be given loose slack to avoid from becoming smaller than the minimum bend radius, and it should not be twisted. When bundling the cable, fix and hold it in position by using cushioning such as sponge or rubber which does not contain migratable plasticizing.

If using adhesive tape for bundling the cable, fire resistant acetate cloth adhesive tape 570F (Teraoka Seisakusho Co., Ltd) is recommended.

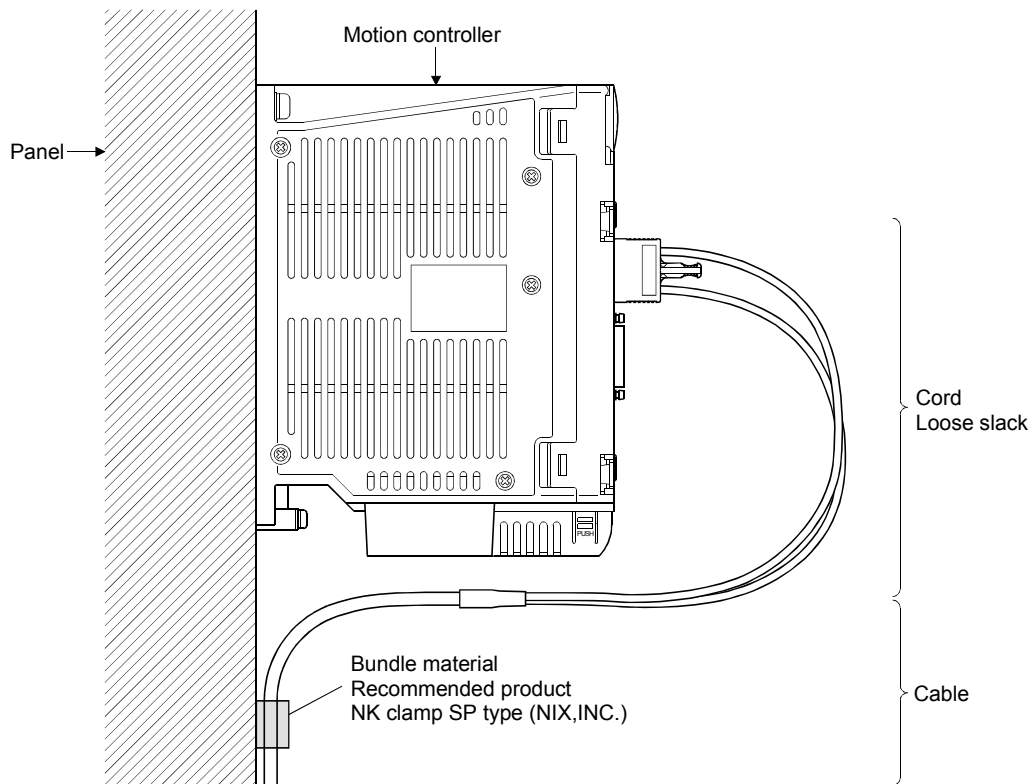

POINTS

- (1) Be sure to connect SSCNETIII cable with the above connector. If the connection is mistaken, between the Motion controller and servo amplifier cannot be communicated.
- (2) Forcibly removal the SSCNETIII cable from the Motion controller will damage the Motion controller and SSCNETIII cables.
- (3) After removal of the SSCNETIII cable, be sure to put a cap on the SSCNETIII connector. Otherwise, adhesion of dirt deteriorates in characteristic and it may cause malfunctions.
- (4) Do not remove the SSCNETIII cable while turning on the power supply of Motion controller and servo amplifier.
Do not see directly the light generated from SSCNETIII connector of Motion controller or servo amplifier and the end of SSCNETIII cable. When the light gets into eye, may feel something is wrong for eye. (The light source of SSCNETIII cable complies with class1 defined in JISC6802 or IEC60825-1.)
- (5) If the SSCNETIII cable is added a power such as a major shock, lateral pressure, haul, sudden bending or twist, its inside distorts or brakes, and optical transmission will not be available.
Be sure to take care enough so that the short SSCNETIII cable is added a twist easily.
- (6) Be sure to use the SSCNETIII cable within the range of operating temperature described in this manual. Especially, as optical fiber for MR-J3BUS□M and MR-J3BUS□M-A are made of synthetic resin, it melts down if being left near the fire or high temperature. Therefore, do not make it touched the part which becomes high temperature, such as radiator or regenerative option of servo amplifier, or servomotor.
- (7) When laying the SSCNETIII cable, be sure to secure the minimum cable bend radius or more.
- (8) Put the SSCNETIII cable in the duct or fix the cable at the closest part to the Motion controller with bundle material in order to prevent SSCNETIII cable from putting its own weight on SSCNETIII connector.
When laying cable, the optical cord should be given loose slack to avoid from becoming smaller than the minimum bend radius, and it should not be twisted.
When bundling the cable, fix and hold it in position by using cushioning such as sponge or rubber which does not contain migratable plasticizing.
If using adhesive tape for bundling the cable, fire resistant acetate cloth adhesive tape 570F (Teraoka Seisakusho Co., Ltd) is recommended.

POINTS

- (9) Migrating plasticizer is used for vinyl tape. Keep the MR-J3BUS□M, and MR-J3BUS□M-A cables away from vinyl tape because the optical characteristic may be affected.

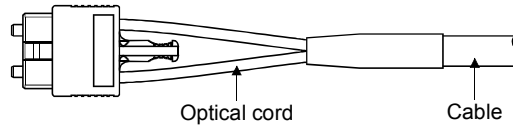

SSCNET III cable	Cord	Cable
MR-J3BUS□M	△	△
MR-J3BUS□M-A	△	△
MR-J3BUS□M-B	○	○

○: Cable is not affected by plasticizer.

△: Phthalate ester plasticizer such as DBP and DOP may affect optical characteristic of cable.

Generally, soft polyvinyl chloride (PVC), polyethylene resin (PE) and Teflon (fluorine resin) contain non-migrating plasticizer and they do not affect the optical characteristic of SSCNET III cable. However, some wire sheaths and cable ties, which contain migrating plasticizer (phthalate ester), may affect MR-J3BUS□M and MR-J3BUS□M-A cables. In addition, MR-J3BUS□M-B cable is not affected by plasticizer.

- (10) If the adhesion of solvent and oil to the cord part of SSCNET III cable may lower the optical characteristic and machine characteristic. If it is used such an environment, be sure to do the protection measures to the cord part.
- (11) When keeping the Motion controller or servo amplifier, be sure to put on a cap to connector part so that a dirt should not adhere to the end of SSCNET III connector.
- (12) SSCNET III connector to connect the SSCNET III cable is put a cap to protect light device inside connector from dust. For this reason, do not remove a cap until just before connecting SSCNET III cable. Then, when removing SSCNET III cable, make sure to put a cap.
- (13) Keep the cap and the tube for protecting light cord end of SSCNET III cable in a plastic bag with a zipper of SSCNET III cable to prevent them from becoming dirty.
- (14) When exchanging the Motion controller or servo amplifier, make sure to put a cap on SSCNET III connector. When asking repair of Motion controller or servo amplifier for some troubles, make also sure to put a cap on SSCNET III connector. When the connector is not put a cap, the light device may be damaged at the transit. In this case, exchange and repair of light device is required.

4.2.2 Forced stop input cable

(1) Precautions for handling the forced stop input cable

- For connection or removal of the forced stop input cable, do it surely while holding a connector of forced stop input cable.

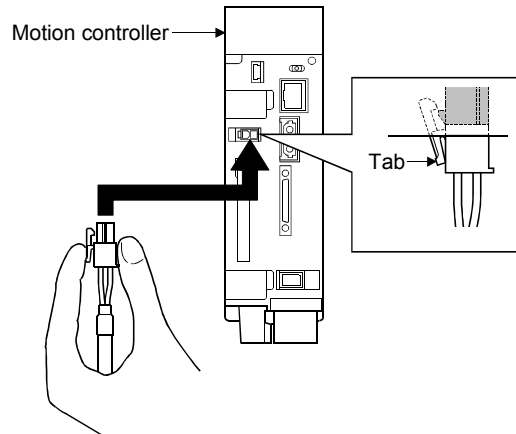

(2) Connection of the forced stop input cable

- For connection of a forced stop input cable to the Motion controller, connect it surely to a EMI connector of Motion controller while holding a connector. Be sure to insert it until it clicks.

(3) Removal of the forced stop input cable

- For removal of the forced stop input cable, push a tab and pull out the cable while holding a connector.

POINTS
Forcibly removal the forced stop input cable from the Motion controller will damage the Motion controller or forced stop input cable.

4.2.3 24VDC power supply cable

(1) Precautions for handling the 24VDC power supply cable

- For connection or removal of the 24VDC power supply cable, do it surely while holding a connector of 24VDC power supply cable.

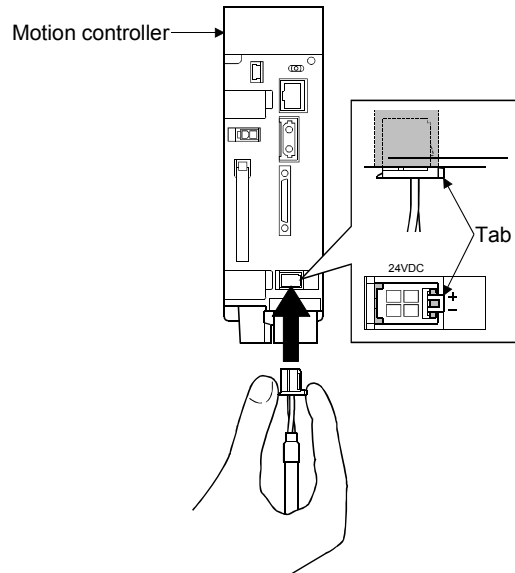

(2) Connection of the 24VDC power supply cable

- For connection of a 24VDC power supply cable to the Motion controller, connect it surely to a 24VDC power supply connector of Motion controller while holding a connector. Be sure to insert it until it clicks.

(3) Removal of the 24VDC power supply cable

- For removal of the 24VDC power supply cable, push a tab and pull out the cable while holding a connector.

POINTS
Forcibly removal the 24VDC power supply cable from the Motion controller will damage the Motion controller or 24VDC power supply cable.

4 INSTALLATION AND WIRING

4.3 Wiring

4.3.1 Instructions for wiring

DANGER

- Completely turn off the externally supplied power used in the system before installation or placing wiring. Not doing so could result in electric shock or damage to the product.
- When turning on the power supply or operating the module after wiring, be sure that the module's terminal covers are correctly attached. Not attaching the terminal cover could result in electric shock.

CAUTION

- Be sure to ground of the earth terminal FG and LG. Not doing so could result in electric shock or operation failure. (Ground resistance: 100Ω or less)
- When wiring in the Motion controller, be sure that it is done correctly by checking the product's rated voltage and the terminal layout. Connecting a power supply that is different from the rating or incorrectly wiring the product could result in fire or damage.
- External connections shall be crimped or pressure welded with the specified tools, or correctly soldered. Imperfect connections could result in short circuit, fire, or operation failure.
- Tighten the terminal screws within the specified torque range. If the terminal screws are loose, it could result in short circuit, fire, or operation failure. Tightening the terminal screws too far may cause damages to the screws and/or the module, resulting in drop, short circuit, or operation failure.
- Be sure there are no foreign matters such as sawdust or wiring debris inside the module. Such debris could cause fire, damage, or operation failure.
- The module has an ingress prevention label on its top to prevent foreign matter, such as wiring debris, from entering the module during wiring.
Do not remove this label during wiring.
Before starting system operation, be sure to remove this label because of heat dissipation.

This section described instructions for the wiring of the power supply.

(1) Power supply wiring

- (a) 24VDC power supply wires should be twisted as dense as possible. Connect them with the shortest distance.

Also, to reduce the voltage drop to the minimum, use the thickest wires (Up to 2.0mm²) possible.

Use the wires of the following core size for wiring.

Application	Recommended core size	AWG ^(Note-1)
24VDC power supply wires	0.34 to 0.37mm ²	#22
I/O equipment	0.3 to 0.75mm ² (Outside diameter 2.8mm (0.11inch) or less)	#18 to #22
Ground wire	2.0mm ² or more	#14 or less

(Note-1): AWG stands for "American Wire Gauge". AWG is a unit of the thickness of conducting wire.

4 INSTALLATION AND WIRING

- (b) Do not bundle the 24VDC power supply wires with, or run them close to, the main circuit (high voltage, large current) and I/O signal lines (including common line).
Reserve a distance of at least 100mm (3.94inch) from adjacent wires.

- (c) Momentary power failure may be detected or the Motion controller may be reset due to surge caused by lightning.
As measures against surge caused by lightning, connect a surge absorber for lightning as shown below.
Using the surge absorber for lightning can reduce the influence of lightning.

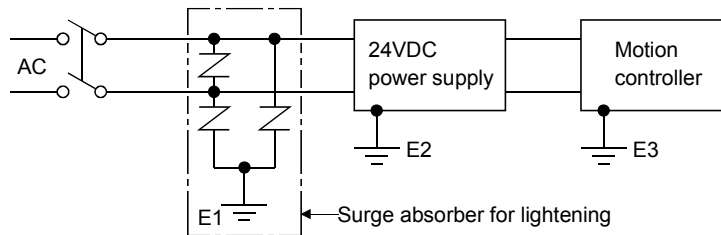

POINTS

- (1) Separate the ground of the surge absorber for lightning (E1), 24VDC power supply (E2) and Motion controller (E3).
- (2) Select a surge absorber for lightning whose power supply voltage does not exceed the maximum allowable circuit voltage even at the time of maximum power supply voltage elevation.

(2) Wiring of I/O equipment

- (a) Insulation-sleeved crimping terminals cannot be used with the terminal block.
It is recommended to cover the wire connections of the crimping terminals with mark or insulation tubes.
- (b) The wires used for connection to the terminal block should be 0.3 to 0.75mm^2 in core and 2.8mm (0.11inch) or less in outside diameter.
- (c) Run the input and output lines away from each other.
- (d) When the wiring cannot be run away from the main circuit and power lines, use a batch-shielded cable and ground it on the Motion controller side. In some cases, ground it in the opposite side.

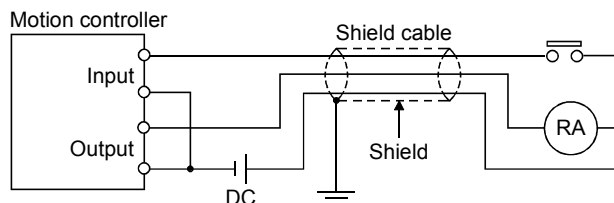

- (e) Where wiring runs through piping, ground the piping without fail.
- (f) Run the 24VDC input line away from the 100VAC and 200VAC lines.
- (g) Wiring of 200m (656.17ft.) or longer distance will give rise to leakage currents due to the line capacity, resulting in a fault.
Refer to the troubleshooting chapter of the I/O Module User's Manual.
- (h) As a countermeasure against the power surge due to lightning, separate the AC wiring and DC wiring and connect a surge absorber for lightning (Refer to Section 4.3.1(1)).
Failure to do so increases the risk of I/O device failure due to lightning.

(3) Grounding

For grounding, follow the steps (a) to (c) shown below.

- (a) Use a dedicated grounding wire as far as possible.
(Ground resistance: 100Ω or less)
- (b) When a dedicated grounding cannot be performed, use (2) Common Grounding shown below.

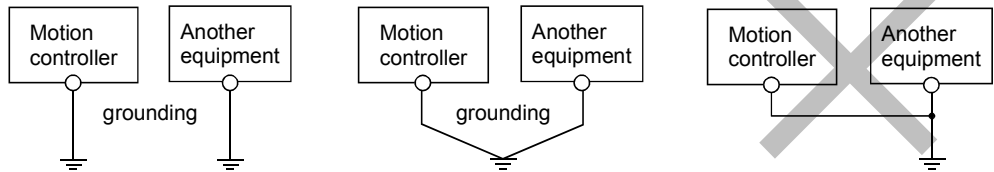

(1) Independent grounding.....Best (2) Common grounding.....Good (3) Joint grounding.....Not allowed

- (c) For grounding a cable, use the cable of 2 mm² or more.
Position the ground-contact point as nearly to the Motion controller as possible, and reduce the length of the grounding cable as much as possible.

4 INSTALLATION AND WIRING

4.3.2 Connecting to the power supply

The following diagram shows the wiring example of power lines, grounding lines, etc. to the Motion controller.

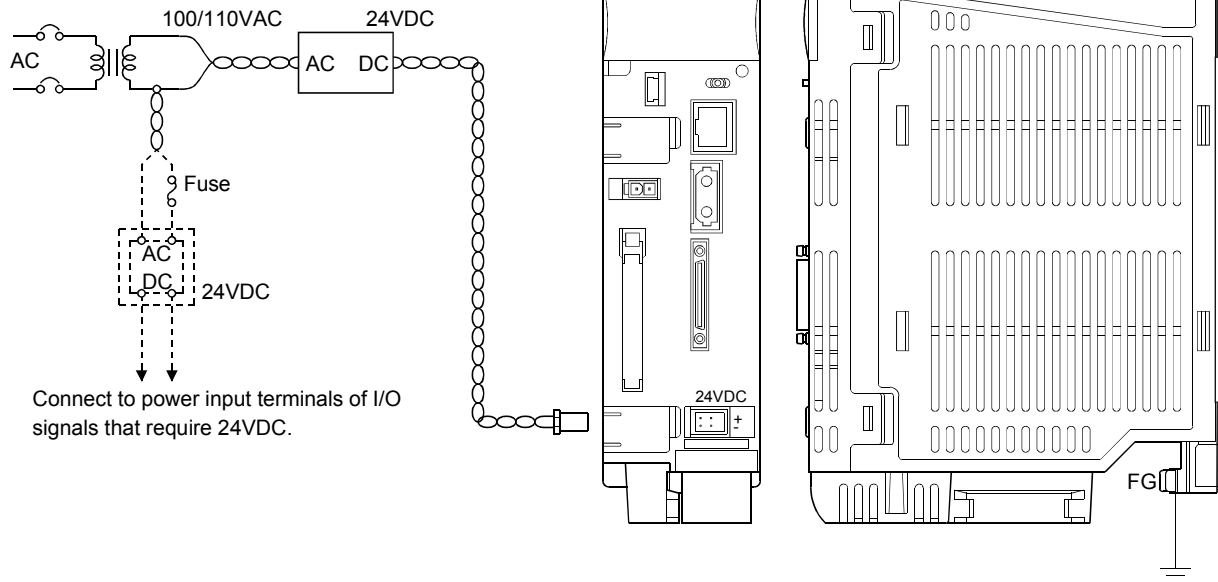

POINT

- (1) Use a different 24VDC power supply for the Motion controller and for I/O signals.
- (2) Use a different 24VDC power supplies for the Motion controller and the electromagnetic brake of the servo motor.
- (3) Refer to Section 2.5.1(9) for the pin layout of 24VDC power supply connector, and refer to APPENDIX 4.3 for the connection diagram of 24VDC power supply cable.
- (4) Motion controller and 24VDC power supply are an open type device and must be installed in a control panel for use.
This not only ensures safety but also ensures effective shielding for Motion controller and 24VDC power supply generated electromagnetic noise.

5. START-UP PROCEDURES

5.1 Check Items before Start-up

Table 5.1 Check items before start-up

Part name	Confirmation Items	Check	Reference
Q170MCPU Motion controller	(1) Check for looseness, rattling or distorted installation.	<input type="checkbox"/>	4.1.2
	(2) Check that the module fixing screw tightening torque is as specified.	<input type="checkbox"/>	4.1.1
	(3) Check that the wire sizes of cables are correct.	<input type="checkbox"/>	4.3.1
	(4) Check that the power line is wired correctly.	<input type="checkbox"/>	
	(5) Check that FG is wired correctly.	<input type="checkbox"/>	4.3.2
	(6) Check that the FG terminal screws are tightened correctly.	<input type="checkbox"/>	
	(7) Check that the FG terminal screws are tightening torque is as specified.	<input type="checkbox"/>	4.1.1
	(8) Check that the 24VDC wires are twisted as closely as possible and run in the shortest distance.	<input type="checkbox"/>	4.3.1
	(9) Check that the 24VDC wires are not bind the cable together with and run close to the power wires.	<input type="checkbox"/>	
	(10) Check that grounding of the earth terminal FG.	<input type="checkbox"/>	4.3
	(11) Check that the forced stop input is wired correctly.	<input type="checkbox"/>	3.2
	(12) Check that the battery is installed.	<input type="checkbox"/>	4.1.4
	(13) Check that the battery lead connector is connected correctly.	<input type="checkbox"/>	
Extension base unit	(1) Check that the extension base unit is Q52B or Q55B (type not requiring power supply module).	<input type="checkbox"/>	2.5.2
	(2) Check that the model name of module is correct.	<input type="checkbox"/>	2.3
	(3) Check that the damage for installed modules.	<input type="checkbox"/>	
	(4) Check that the modules are installed correctly.	<input type="checkbox"/>	4.1.3
	(5) Check for looseness, rattling or distorted installation.	<input type="checkbox"/>	4.1.2
	(6) Check that the module fixing screw tightening torque is as specified.	<input type="checkbox"/>	4.1.1
	(7) Check that the total I/O points of I/O modules and intelligent function modules do not exceed the I/O points of the Motion controller.	<input type="checkbox"/>	Refer to the "Q173DCPU/Q172DCPU Motion controller Programming Manual(COMMON)", or "QCPU User's Manual (Hardware Design, Maintenance and Inspection).
Q172DLX Servo external signals interface module/ Q173DPX Manual pulse generator interface module	(1).Check that the installation position of modules correspond to the system setting.	<input type="checkbox"/>	Refer to the "Q173DCPU/Q172DCPU Motion controller Programming Manual(COMMON).
	(2) Check that the connection with external equipments is correct.	<input type="checkbox"/>	2.5.3 2.5.4

5 START-UP PROCEDURES

Part name	Confirmation Items	Check	Reference
I/O module	(1) Check that the wire size of cable is correct.	<input type="checkbox"/>	Refer to the I/O Module Type Building Block User's Manual
	(2) Check that the terminal block screws are tightened correctly.	<input type="checkbox"/>	
	(3) Check that the cables connected to each terminal of terminal block correspond to the signal names.	<input type="checkbox"/>	
	(4) Check that the external power supply are connected correctly. (24VDC, 5VDC)	<input type="checkbox"/>	
	(5) Check that the 100VAC, 200VAC and 24VDC wires are twisted as closely as possible respectively and run in the shortest distance.	<input type="checkbox"/>	4.3.1
	(6) Check that the 100VAC, 200VAC and 24VDC wires are not bind the cable together with and run close to the I/O wires.	<input type="checkbox"/>	
	(7) Check that the I/O wires are wired correctly.	<input type="checkbox"/>	
SSCNET III cable	(1) Check that the model name of SSCNET III cables is correct.	<input type="checkbox"/>	2.5.6
	(2) Check that the connecting position for connector of SSCNET III cables are correct.		
	(3) Check that the SSCNET III cables are connected correctly.	<input type="checkbox"/>	4.2.1
	(4) Check for looseness, rattling or distorted connection.	<input type="checkbox"/>	
	(5) Check that the minimum bend radius or more secured.	<input type="checkbox"/>	
	(6) Check that the MR-J3BUS□M or MR-J3BUS□M-A do not come in contact with wires/cables that use materials where the plasticizing material is contained.	<input type="checkbox"/>	

5 START-UP PROCEDURES

5.2 Start-up Adjustment Procedure

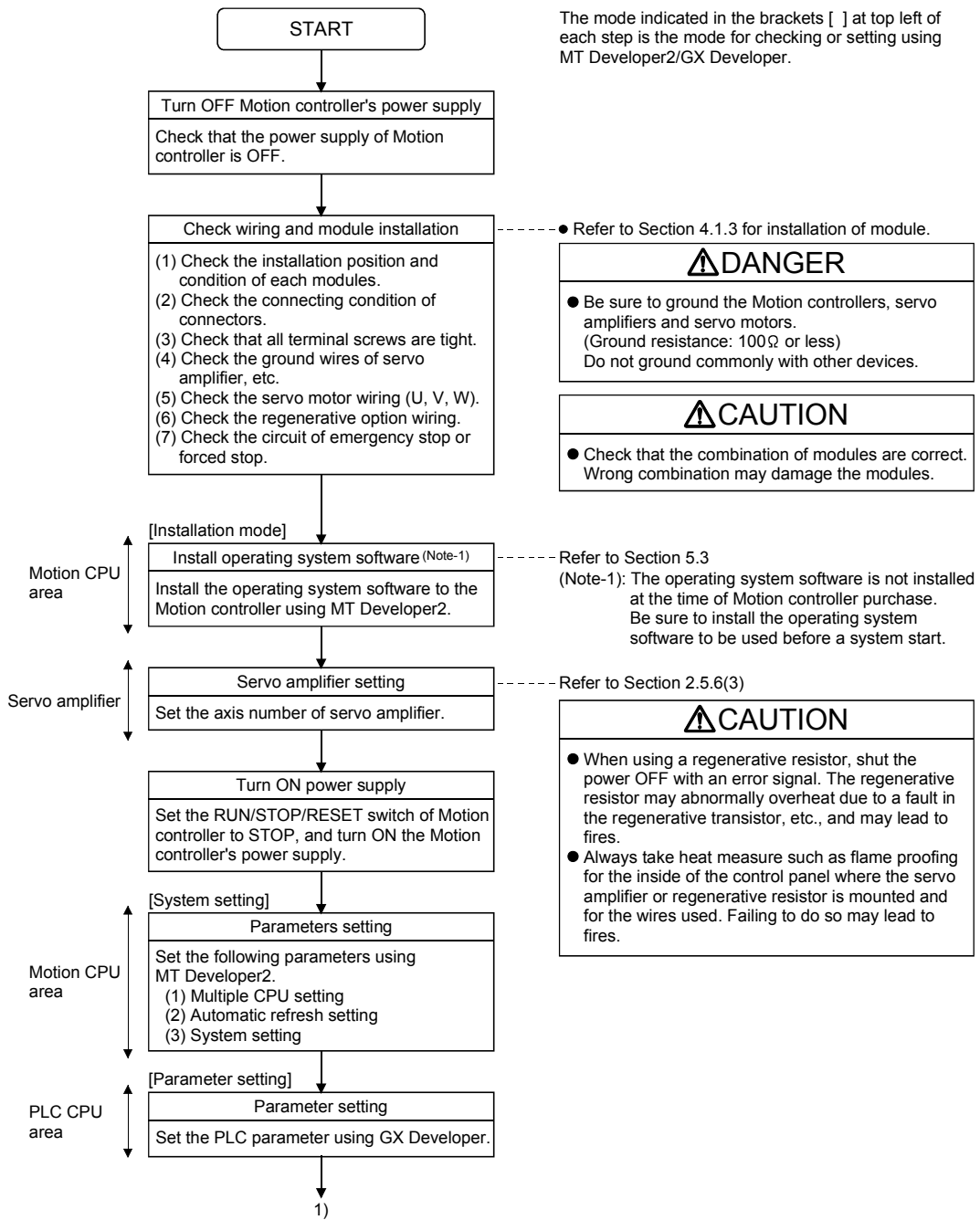

5 START-UP PROCEDURES

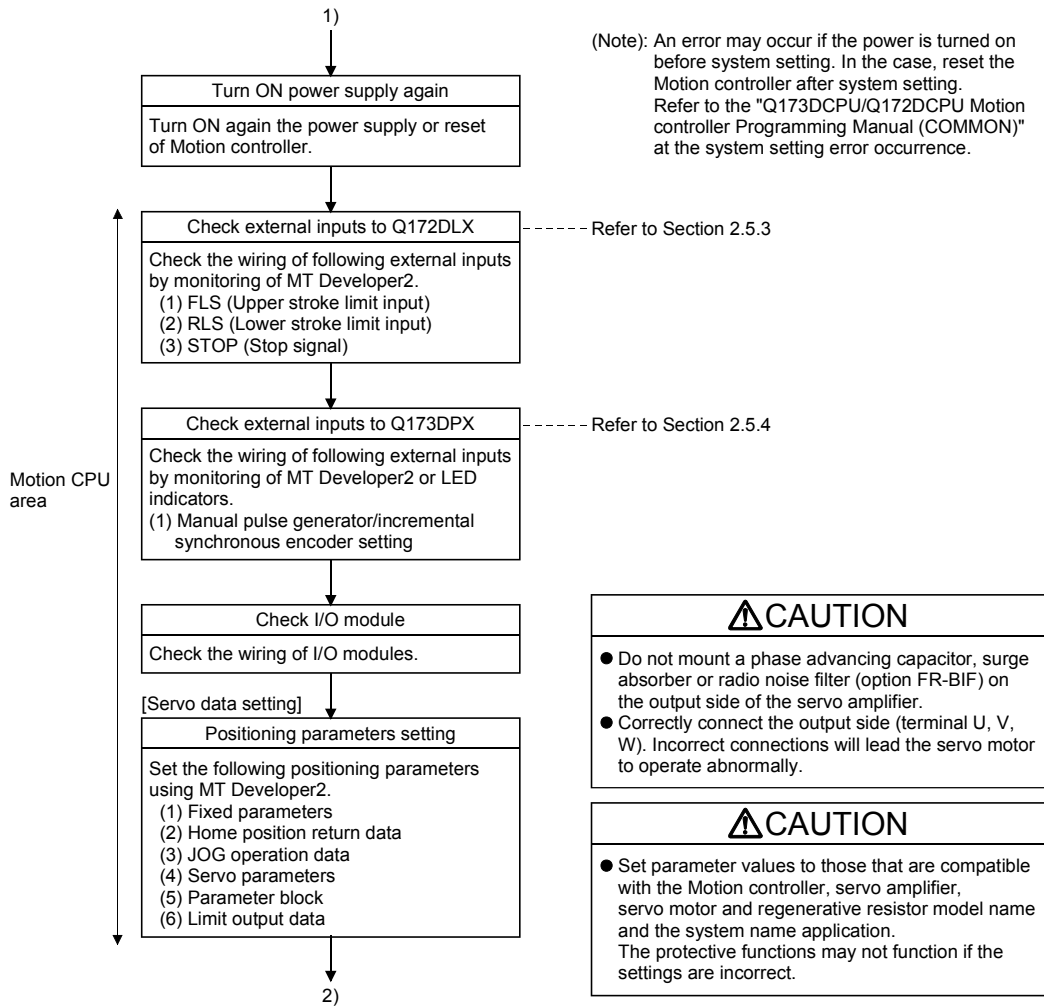

5 START-UP PROCEDURES

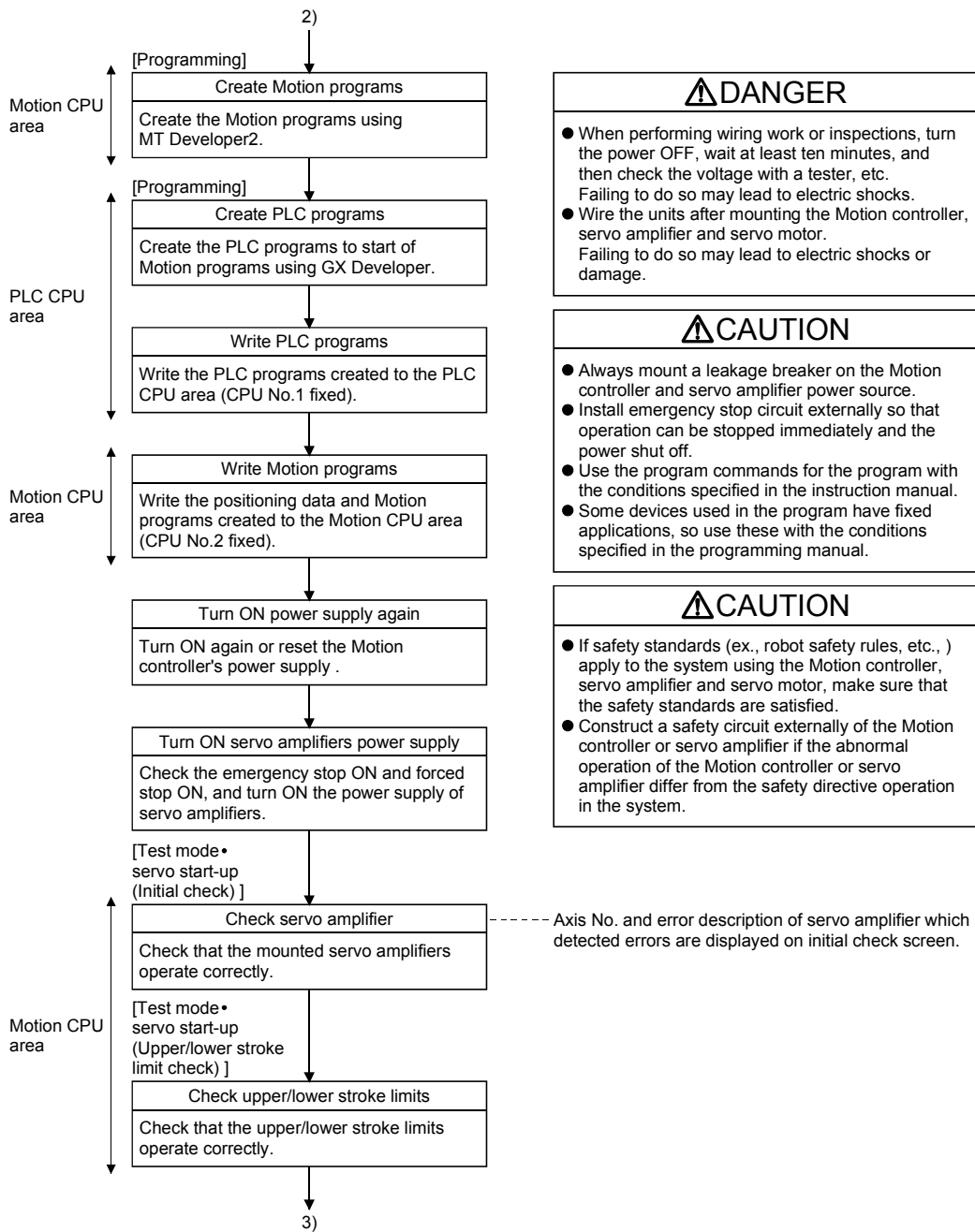

5 START-UP PROCEDURES

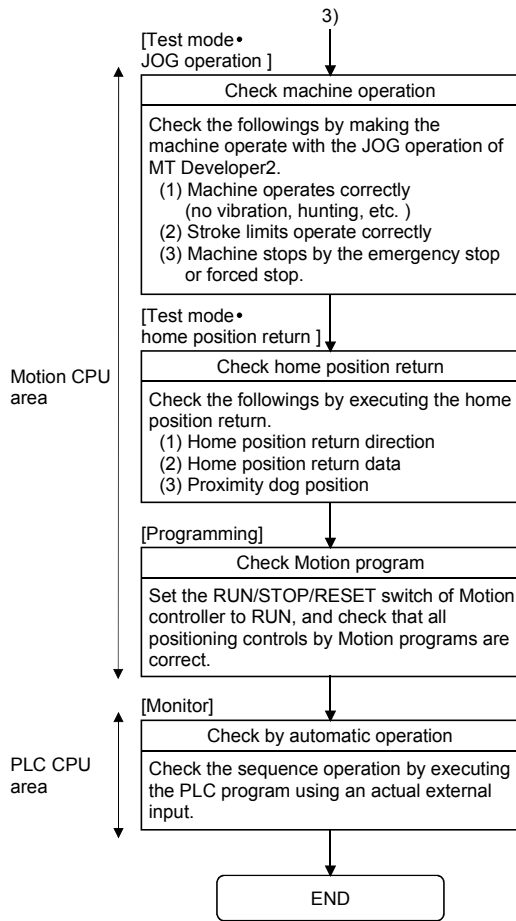

CAUTION
<ul style="list-style-type: none"> ● The system must have a mechanical allowance so that the machine itself can stop even if the stroke limits switch is passed through at the max. speed. ● Execute the test operation in the system that it is low-speed as much as possible and put forced stop, and confirm the operation and safety.

POINTS
<p>(1) Make note of servo motor module names before the servo motor is mounted on a machine. The servo motor rating plate may not be visible after the servo motor is mounted.</p> <p>(2) When the servo amplifier, servo motor is first turned on, check the operation before the servo motor is mounted on a machine to avoid an unexpected accidents such as machine breakage.</p>

5 START-UP PROCEDURES

5.3 Operating System Software Installation Procedure

The operating system software must be installed to the Motion controller by using the peripheral device and MT Developer2.

The installation procedure is shown below.

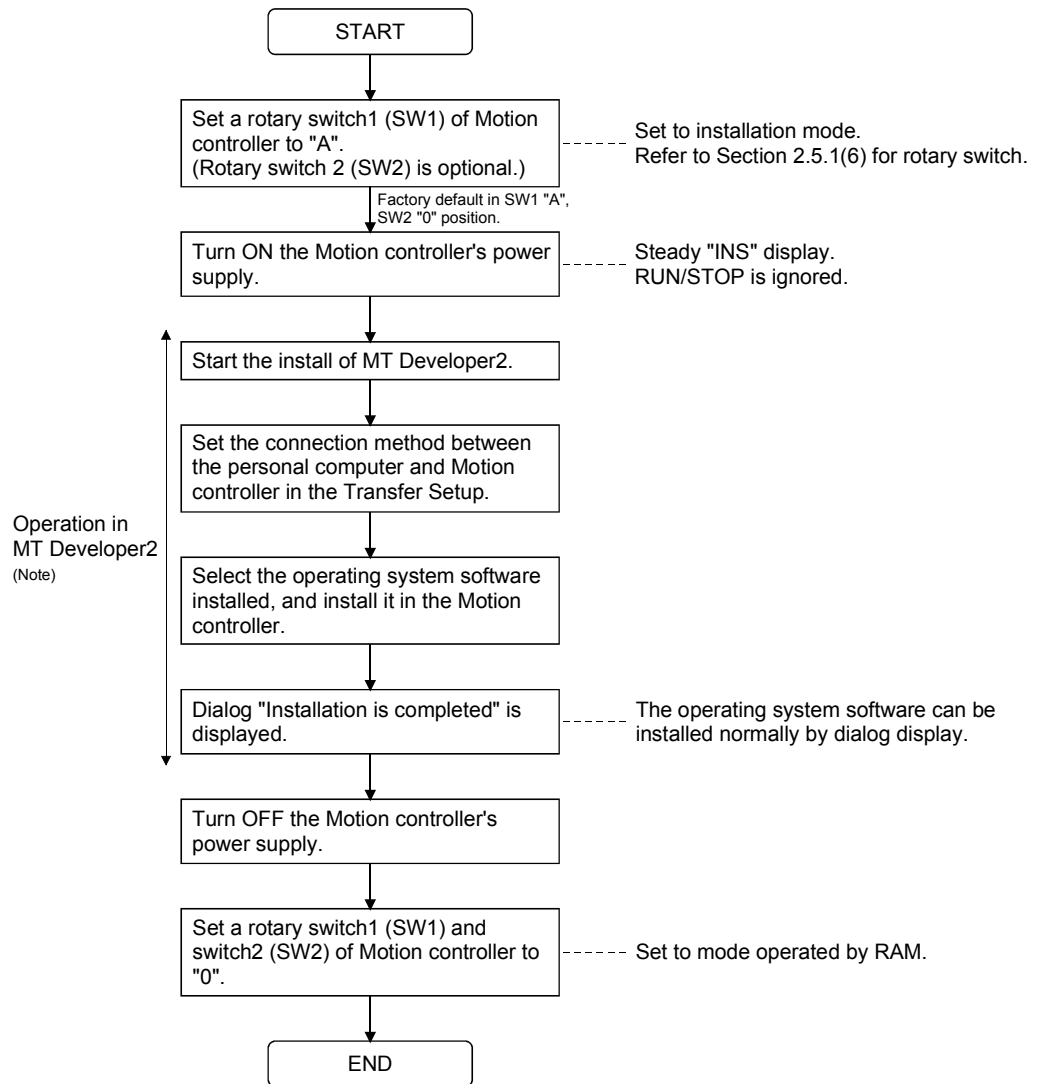

(Note): Install the operating system software by screen of MT Developer2. Refer to help of MT Developer2 for details.

5 START-UP PROCEDURES

POINTS
<p>(1) The operating system software was not installed at the time of Motion controller purchase. Be sure to install the operating system software to be used before a system start.</p> <p>(2) The operating system software is installed to the Motion CPU area. It has already been installed to the PLC CPU area. The PLC CPU area is never rewritten.</p> <p>(3) Be sure to change a rotary switch after turning off the power supply.</p> <p>(4) Even if the operating system software is installed, the programs, parameters and absolute position data written in the Motion controller do not be rewritten.</p> <p>(5) Do not do any of the following while installing operation system software. Doing so could result damage the Motion controller.</p> <ul style="list-style-type: none">• Turn OFF the Motion controller's power supply.• Change the RUN/STOP/RESET switch of Motion controller to RESET.• Turn OFF the power supply of the personal computer.• Pull out the personal computer's communication's cable.

5 START-UP PROCEDURES

5.4 Trial Operation and Adjustment Checklist

At the worksite, copy the following table for use as a check sheet.

Work Step	Item	Check Items	Check	
Before power supply ON	Installation of unit/module and basic wiring	Check that the each module is installed correctly.	<input type="checkbox"/>	
		Check that the each connector is connected correctly.	<input type="checkbox"/>	
		Check the each terminal screw for looseness.	<input type="checkbox"/>	
		Check that the earth wires of Motion controller or servo amplifiers, etc. are correct.	<input type="checkbox"/>	
		Check that the servomotor wiring is correct.	<input type="checkbox"/>	
		Check that the regenerative option wiring is correct.	<input type="checkbox"/>	
		Check that the circuit of emergency stop and forced stop are correct.	<input type="checkbox"/>	
		Check that the wiring of each power supply and I/O are correct.	<input type="checkbox"/>	
Power supply ON/ Motion controller in STOP status	Installation of OS System setting	Check that the operating system software is compatible.	<input type="checkbox"/>	
		Check that the system setting is correct.	<input type="checkbox"/>	
	Q172LX external signal	Check that the upper/lower stroke limit inputs are correct.	<input type="checkbox"/>	
		Check that the STOP signal input is correct.	<input type="checkbox"/>	
		Check that the proximity dog and speed/position switching signal input are correct.	<input type="checkbox"/>	
	Program/ positioning data	Check that the Motion program, PLC program and positioning data are stored in the Motion controller correctly.	<input type="checkbox"/>	
		Basic axis operations (Check each axis)	Check the communications with servo amplifiers.	<input type="checkbox"/>
			Check that the rotation direction for JOG operation is correct.	<input type="checkbox"/>
			Check that the upper/lower limit switches operate correctly.	<input type="checkbox"/>
			Check that the rotation at maximum command speed is motor rating or less.	<input type="checkbox"/>
			Check that the machine operates correctly by the JOG operation.	<input type="checkbox"/>
			Check that the machine stops by the upper/lower stroke limit.	<input type="checkbox"/>
			Check that the machine stops by the emergency stop or forced stop.	<input type="checkbox"/>
	Check that the home position return is executed correctly.	<input type="checkbox"/>		
Motion controller in RUN status	Manual operation	Check the each operation in manual operation mode of system during Motion program execution.		
		Check that the machine operation stops immediately by the emergency stop or forced stop.	<input type="checkbox"/>	
		Check the operation of each actuator and confirmation limit switch.	<input type="checkbox"/>	
		Check that the emergency stop, forced stop and equipment alarm signals are correct.	<input type="checkbox"/>	
		Checks in compliance with control specifications specific to system and equipment.	<input type="checkbox"/>	
	Automatic operation	Check the each operation in automatic operation mode of system during Motion program execution.		
		Check that the automatic operation motions.	<input type="checkbox"/>	
		Check that the machine operation stops immediately by the emergency stop or forced stop.	<input type="checkbox"/>	
		Check that the module or equipment alarm causes an immediate stop or cycle stop.	<input type="checkbox"/>	
		Check that the restoring operation can be performed after an alarm stop.	<input type="checkbox"/>	
	Torque check	Make other checks in compliance with control specifications specific to system and equipment.	<input type="checkbox"/>	
		Check that the acceleration/deceleration torque is maximum torque or less.	<input type="checkbox"/>	
		Check that the continuous effective load torque is rated torque or less.	<input type="checkbox"/>	

6. INSPECTION AND MAINTENANCE

DANGER

- Do not touch the terminals while power is on. Doing so could cause electric shock.
- Correctly connect the battery. Also, do not charge, disassemble, heat, place in fire, short circuit, or solder the battery.
Mishandling of a battery may cause overheating, cracks or ignition which could result in injury and fire.
- Switch off all phases of the externally supplied power used in the system when cleaning the module or retightening the terminal or module mounting screws.
Not doing so could result in electric shock.
Under tightening of terminal screws can cause a short circuit or malfunction.
Over tightening of screws can cause damages to the screws and/or the module, resulting in fallout, short circuits, or malfunction.
- The capacitor is mounted to the modules. Do not incinerate the modules so that the incineration of capacitor may cause burst.
For disposal of the modules, request for specialized industrial waste disposal services who has incineration facility.

CAUTION

- Read the manual carefully and pay careful attention to safety for the on-line operation (especially program change, forced stop or operation change) performed by connecting peripheral devices to the Motion controller during operation.
Erroneous operation may cause machine breakage or accident.
- Never try to disassemble or modify module. It may cause product failure, operation failure, injury or fire.
- Use any radio communication device such as a cellular phone or a PHS phone more than 25cm (9.84 inch) away in all directions of the Motion controller.
Failure to do so may cause a malfunction.
- Completely turn off the externally supplied power used in the system before installation or removing the module. Not doing so could result in electric shock, damage to the module or operation failure.
- Do not install/remove the module on to/from base unit or terminal block more than 50 times, after the first use of the product. Failure to do so may cause the module to malfunction due to poor contact of connector.
- Do not drop or impact the battery installed to the module. Doing so may damage the battery, causing battery liquid to leak in the battery.
Do not use the dropped or impacted battery, but dispose of it.
- Before touching the module, always touch grounded metal, etc. to discharge static electricity from human body. Failure to do so may cause the module to fail or malfunction.
- Do not directly touch the module's conductive parts and electronic components. Touching them could cause an operation failure or give damage to the module.

In order that you can use the Motion controller in normal and optimal condition at all times, this section describes those items that must be maintained or inspected daily or at regular intervals.

6 INSPECTION AND MAINTENANCE

6.1 Maintenance Works

6.1.1 Instruction of inspection works

In order that can use the Motion controller in safety and normal, those items that must be inspected list below.

DANGER

- Never open the front case or terminal covers while the power is ON or the unit is running, as this may lead to electric shocks.
- Never run the unit with the front case or terminal cover removed. The high voltage terminal and charged sections will be exposed and may lead to electric shocks.
- Never remove the front case or terminal cover at times other than wiring work or periodic inspections even if the power is OFF. The insides of the Motion controller and servo amplifier are charged and may lead to electric shocks.
- When performing wiring work or inspections, turn the power OFF, wait at least ten minutes, and then check the voltage with a tester, etc. Failing to do so may lead to electric shocks.
- Never operate the switches with wet hands, as this may lead to electric shocks.
- Do not damage, apply excessive stress, place heavy things on or sandwich the cables, as this may lead to electric shocks or fire.
- Do not touch the Motion controller, servo amplifier or servomotor terminal blocks while the power is ON, as this may lead to electric shocks or fire.
- Do not touch the built-in power supply, built-in grounding or signal wires of the Motion controller and servo amplifier, as this may lead to electric shocks.

CAUTION

- Be sure to ground the Motion controller, servo amplifier and servomotor. Do not ground commonly with other devices. (Ground resistance : 100 Ω or less)
- The wiring work and inspections must be done by a qualified technician.
- Wire the units after mounting the Motion controller, servo amplifier and servomotor. Failing to do so may lead to electric shocks or damage.
- Perform the daily and periodic inspections according to the instruction manual.
- Perform maintenance and inspection after backing up the program and parameters for the Motion controller and servo amplifier.
- Do not place fingers or hands in the clearance when opening or closing any opening.
- Periodically replace consumable parts such as batteries according to the instruction manual.
- Do not touch the lead sections such as ICs or the connector contacts.
- Do not place the Motion controller or servo amplifier on metal that may cause a power leakage or wood, plastic or vinyl that may cause static electricity buildup.
- Do not perform a megger test (insulation resistance measurement) during inspection.
- When replacing the Motion controller or servo amplifier, always set the new unit settings correctly.
- After maintenance and inspections are completed, confirm that the position detection of the absolute position detector function is correct.

⚠ CAUTION

- Do not short circuit, charge, overheat, incinerate or disassemble the batteries.
- The electrolytic capacitor will generate gas during a fault, so do not place your face near the Motion controller or servo amplifier.
- The electrolytic capacitor and fan will deteriorate. Periodically change these to prevent secondary damage from faults. Replacements can be made by our sales representative.
- If an error occurs in the self diagnosis of the Motion controller or servo amplifier, confirm the check details according to the instruction manual, and restore the operation.
- If a dangerous state is predicted in case of a power failure or product failure, in order to prevent that state, use a servomotor with electromagnetic brakes for maintenance or mount a brake mechanism externally.
- Use a double circuit construction so that the electromagnetic brake operation circuit can be operated by emergency stop signals set externally.

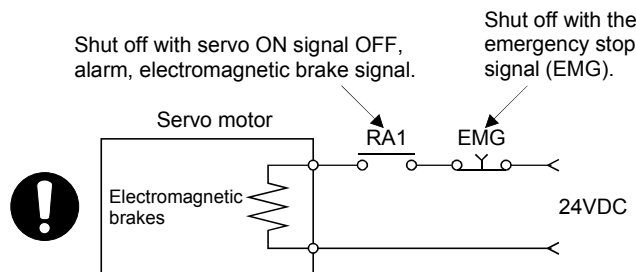

- If an error occurs, remove the cause, secure the safety and then resume operation after alarm release.
- The unit may suddenly restart after a power failure is restored, so do not go near the machine. (Design the machine so that personal safety can be ensured even if the machine restarts suddenly.)
- Confirm and adjust the program and each parameter before operation. Unpredictable movements may occur depending on the machine.
- Extreme adjustments and changes may lead to unstable operation, so never make them.
- Do not apply a voltage other than that specified in the instruction manual on any terminal. Doing so may lead to destruction or damage.
- Do not mistake the terminal connections, as this may lead to destruction or damage.
- Do not mistake the polarity (+ / -), as this may lead to destruction or damage.
- Do not touch the heat radiating fins of controller or servo amplifier, regenerative resistor and servomotor, etc., while the power is ON and for a short time after the power is turned OFF. In this timing, these parts become very hot and may lead to burns.
- Always turn the power OFF before touching the servomotor shaft or coupled machines, as these parts may lead to injuries.
- Do not go near the machine during test operations or during operations such as teaching. Doing so may lead to injuries.
- Do not bunch the control wires or communication cables with the main circuit or power wires, or lay them closely. They should be installed 100mm (3.94inch) or more from each other. Trying to bunch or install could result in noise that would cause operation failure.

6 INSPECTION AND MAINTENANCE

6.2 Daily Inspection

The items that must be inspected daily are shown below.

Table 6.1 Daily Inspection

Item	Inspection item	Inspection	Criterion	Action			
1	Mounting of Motion controller	Check that the fixing screws are not loose and the cover is not dislocated.	The screws and cover must be mounted securely.	Retighten the screws.			
2	Mounting of base unit						
3	Installation of Motion modules and I/O modules	Check that the module is not dislocated and the unit fixing hook is engaged securely.	The module fixing hook must be engaged and installed correctly.	Securely engaged the module fixing hook.			
4	Connecting conditions	Check for loose terminal screws.	Screws should not be loose.	Retighten the terminal screws.			
		Check for distance between solderless terminals.	The proper clearance should be provided between solderless terminals.	Correct.			
		Check the connector part of the cable.	Connections should not be loose.	Retighten the connector fixing screws.			
5	Module indication LED	Motion controller	[POWER] LED	Check that the LED is ON. (Abnormal if the LED is OFF.)	Refer to Section 2.5.1		
			[MODE] LED	Check that the LED is ON. (Abnormal if the LED is OFF or flickering.)			
			[RUN] LED	Check that the LED is ON in RUN status. (Abnormal if the LED is OFF.)			
			[ERR.] LED	Check that the LED is OFF. (Abnormal if the LED is ON or flickering.)			
			[BAT.] LED	Check that the LED is OFF. (Abnormal if the LED is ON (yellow).)			
			Normal		Steady "RUN" display. (Abnormal if "RUN" does not display or incorrect display.)	Refer to Section 6.5	
					Steady "STP" display. (Abnormal if "STP" does not display or incorrect display.)		
			Battery error warning (2.7V or less)		"BT1" does not display. (Abnormal if steady "BT1" display.)		
			Battery error warning (2.5V or less)		"BT2" does not display. (Abnormal if steady "BT2" display.)		
			WDT error		"..." does not display. (Abnormal if steady "..." display.)		Refer to Section 2.5.1
			Others		"AL" does not flash. (Abnormal if "..." flashes.)		
I/O module	Input LED	Check that the LED is ON/OFF.	The LED must be ON when the input power is turned ON. The LED must be OFF when the input power is turned OFF. (Abnormal if the LED does not turn ON or turn OFF as indicated above.)	Refer to "I/O Module Type Building Block User's Manual".			
	Output LED	Check that the LED is ON/OFF.	The LED must be ON when the output power is turned ON. The LED must be OFF when the output power is turned OFF. (Abnormal if the LED does not turn ON or turn OFF as indicated above.)				

6 INSPECTION AND MAINTENANCE

6.3 Periodic Inspection

The items that must be inspected one or two times every 6 months to 1 year are listed below. When the equipment is moved or modified, or layout of the wiring is changed, also implement this inspection.

Table 6.2 Periodic Inspection

Item	Inspection item	Inspection	Criterion	Action	
1	Ambient environment	Ambient temperature	0 to 55 °C (32 to 131 °F)	When the controller is used in the board, the ambient temperature in the board becomes the ambient temperature.	
		Ambient humidity	Measure with a thermometer and a hygrometer. 5 to 95 % RH		
		Atmosphere	Measure corrosive gas. No corrosive gases		
2	Power voltage	Measure a voltage across the terminals of 24VDC.	21.6 to 26.4	Change the power supply.	
3	Installation	Looseness, rattling	Move the module to check for looseness and rattling.	The module must be installed solidly.	Retighten the screws. If the Motion controller, Motion, or I/O, module is loose, fix it with screws.
		Adhesion of dirt and foreign matter	Check visually.	Dirt and foreign matter must not be present.	Remove and clean.
4	Connection	Looseness of terminal screws	Try to further tighten screws with a screwdriver.	Screws must not be loose.	Retighten the terminal screws.
		Proximity of solderless terminals to each other	Check visually.	Solderless terminals must be positioned at proper intervals.	Correct.
		Looseness of connectors	Check visually.	Connectors must not be loose.	Retighten the connector fixing screws.
5	Battery	Check the 7-segment LED at the front side of Motion controller.	Must be turned OFF "BT1" or "BT2" display.	Even if the lowering of a battery capacity is not shown, replace the battery with a new one if a service life time of the battery is exceeded.	
		Check the length of term after purchasing the battery	Must not be used more than 5 years.		
		Check that SM51 or SM58 is turned OFF using MT Developer2 in monitor.	Must be turned OFF.	Replace the battery with a new one when SM51 or SM58 is ON.	

6.4 Life

The following parts must be changed periodically as listed below. However, if any part is found faulty, it must be changed immediately even when it has not yet reached the end of its life, which depends on the operating method and environmental conditions. For parts replacement, please contact your sales representative.

Table 6.3 Life

Module name	Part name	Life guideline	Remark
Motion controller	Electrolytic capacitor	10 years	Life guideline is reference time.
Motion module			It must be changed immediately even when it has not yet reached the life guideline.

(1) Capacitor

The life of the capacitor greatly depends on ambient temperature and operating conditions. The capacitor will reach the end of its in 10 years of continuous operation in normal air-conditioned environment.

6.5 Battery

The battery installed in the Motion controller is used for data retention during the power failure of the program memory and latch device.

The data stored in the RAM built-in Motion controller are shown below.

- PLC CPU area : Clock data, Latch devices (L), Devices of latch range, Error history and Data in standard RAM
- Motion CPU area : Programs, Parameters, Motion devices (#), Devices of latch range, and Absolute position data

Special relays (SM51, SM52, SM58 or SM59) turn on due to the decrease of battery voltage. Even if the special relays turn on, the program and retained data are not erased immediately.

However, if these relays are overlooked, the contents may be erased.

After relay SM51 or SM58 turns on, replace the battery quickly within the data retention time for power failure (3 minutes).

POINT	
(1)	SM51 or SM58 turns on when the battery voltage falls below the specified value, and remains ON even after the battery voltage is recovered to the normal value. SM51 or SM58 turns off by power supply on again or reset.
(2)	After SM51, SM52, SM58 or SM59 turns on, replace the battery quickly. <ul style="list-style-type: none">• SM51 or SM52 turns on at the battery voltage 2.5V or less.• SM58 or SM59 turns on at the battery voltage 2.7V or less.
(3)	If SM51 turns on, the details for the data of RAM built-in Motion controller cannot be guaranteed. It is recommended to back-up the data periodically.

6 INSPECTION AND MAINTENANCE

6.5.1 Battery life

The battery life is shown below.

Battery type	Battery life (Total power failure time) [h] ^(Note-1)				Backup time after alarm
	Power-on time ratio ^(Note-2)	Guaranteed value ^(Note-3) (MIN) (75°C (167°F))	Guaranteed value ^(Note-4) (TYP) (40°C (104°F))	Actual service value ^(Note-5) (Reference value) (TYP) (25°C (77°F))	
Q6BAT ^(Note-7)	0%	13000	40000	43800	90 (After SM51/SM52 ON)
	30%	18000	43800		
	50%	21000			
	70%	24000			
	100%	43800			
Q7BAT (Large-capacity battery) ^(Note-7)	0%	39000	43800	43800	90 (After SM51/SM52 ON)
	30%	43800			
	50%				
	70%				
	100%				

(Note-1) : The actual service value indicates the average value, and the guaranteed time indicates the minimum time.

(Note-2) : The power-on time ratio indicates the ratio of Motion controller power-on time to one day (24 hours).

(When the total power-on time is 17 hours and the total power-off time is 7 hours, the power-on time ratio is 70%.)

(Note-3) : The guaranteed value (MIN) ; equivalent to the total power failure time that is calculated based on the characteristics value of the memory (SRAM) supplied by the manufacturer and under the storage ambient temperature range of -25°C to 75°C (-13 to 167°F) (operating ambient temperature of 0°C to 55°C (32 to 131°F)).

(Note-4) : The guaranteed value (TYP) ; equivalent to the total power failure time that is calculated based on the normal air-conditioned environment (40°C (104°F)).

(Note-5) : The actual service value (Reference value) ; equivalent to the total power failure time that is calculated based on the measured value and under the storage ambient temperature of 25°C (77°F). This value is intended for reference only, as it varies with characteristics of the memory.

(Note-6) : In the following status, the backup time after power OFF is 3 minutes.

- Q6BAT/Q7BAT lead connector is disconnected.
- Lead wire of Q6BAT/Q7BAT is broken.

(Note-7) : Set the battery (Q6BAT/Q7BAT) to battery holder.

POINT

- (1) Do not use the battery exceeding its guaranteed life.
- (2) When the battery hours (total power failure time) may exceed its guaranteed value, take the following measure.
 - Perform ROM operation to protect a program even if the battery dies at the Motion controller's power-OFF.
 - If SM51 or SM52 turns on, the contents for the data (Refer to Section 6.5) of RAM built-in Motion controller cannot be guaranteed. It is recommended to back-up the data periodically.
- (3) When the total power failure time exceeds its guaranteed value, and SM51, SM52, SM58 and SM59 turns on, immediately change the battery. Even if the alarm has not yet occurred, it is recommended to replace the battery periodically according to the operating condition
- (4) The self-discharge influences the life of battery without the connection to the Motion controller. The battery should be exchanged approximately every 4 or 5 years. And, exchange the battery with a new one in 4 to 5 years even if a total power failure time is guaranteed value or less.

6.5.2 Battery replacement procedure

When the battery has been exhausted, replace the battery with a new one in accordance with the procedure shown below.

POINTS
<p>When replacing the battery, pay attention to the following.</p> <p>(1) Back up the data using MT Developer2 before starting replacement.</p> <p>(2) Firstly back up the data stored in the Motion controller to the personal computer which is installed MT Developer2 then replace the battery with a new one. After setting the battery in the Battery holder, verify the backing up the data to the personal computer which is installed MT Developer2 and the data in the Motion controller, confirm the data is not changing.</p> <p>In the following status, the backup time after power OFF is 3 minutes.</p> <ul style="list-style-type: none">• The lead connector of Q6BAT/Q7BAT is disconnected.• The lead wire of Q6BAT/Q7BAT is broken.

(1) Q6BAT

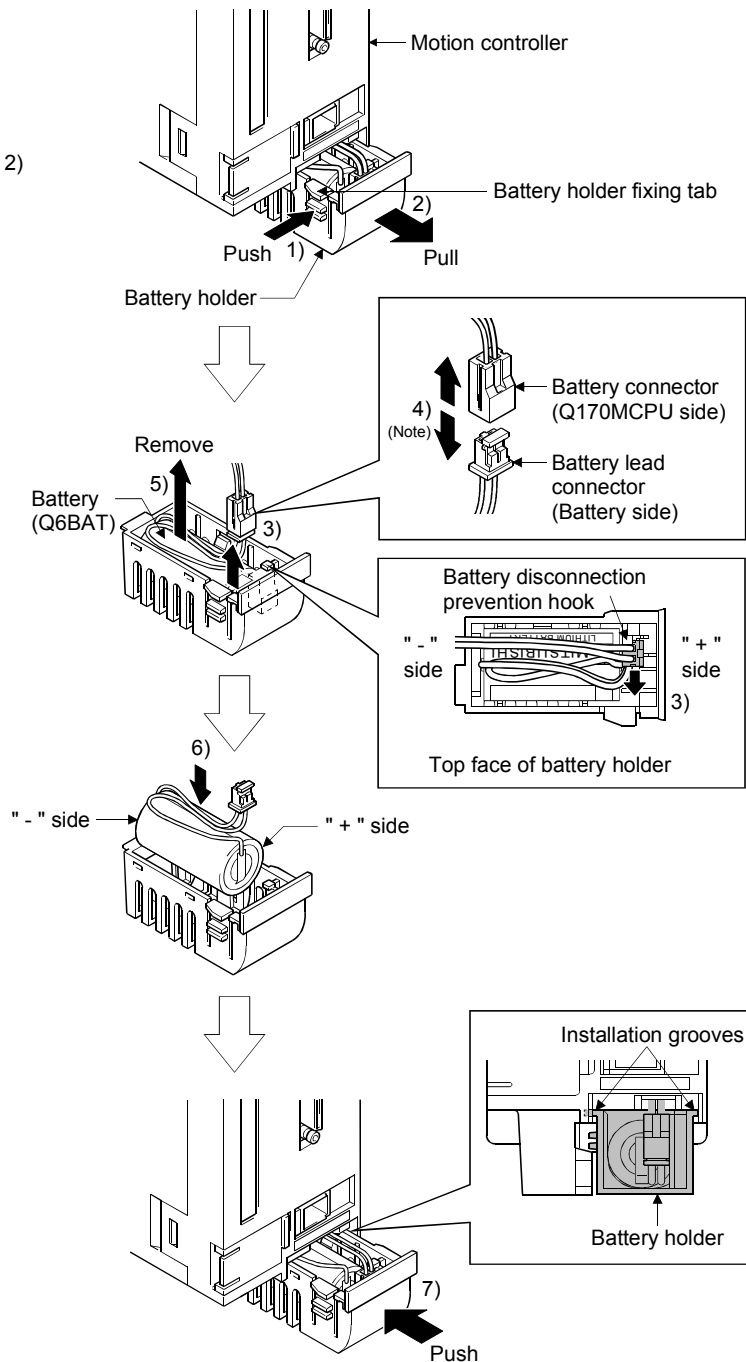
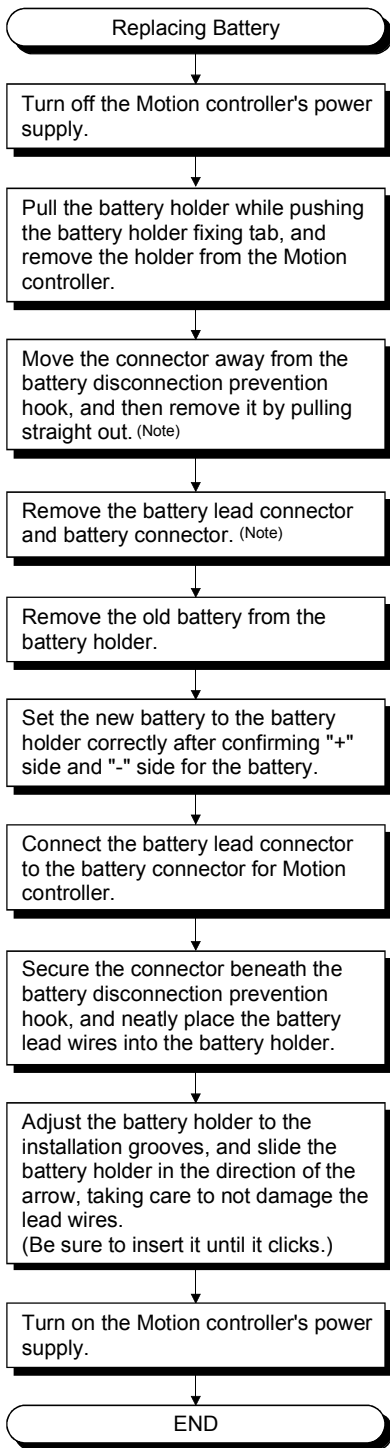

(Note): Do not pull on the lead wire forcibly to remove the connector.

(2) Q7BAT

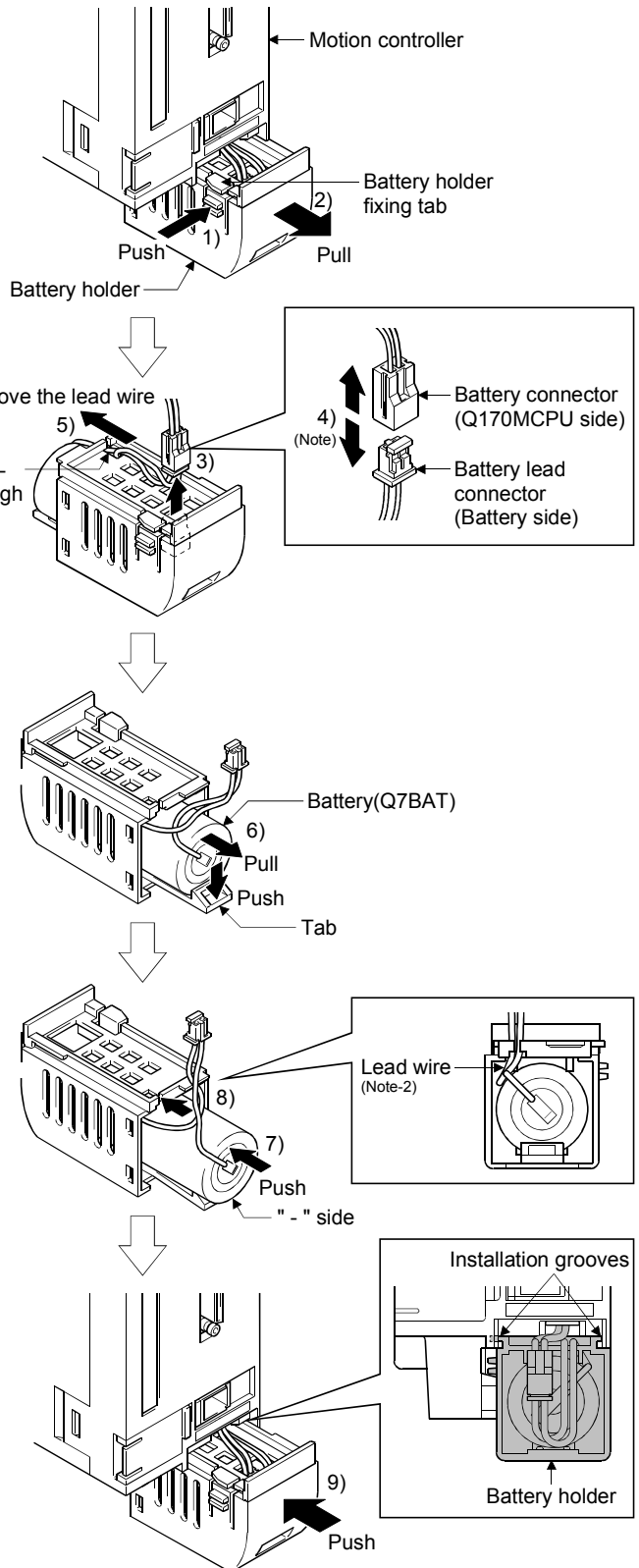
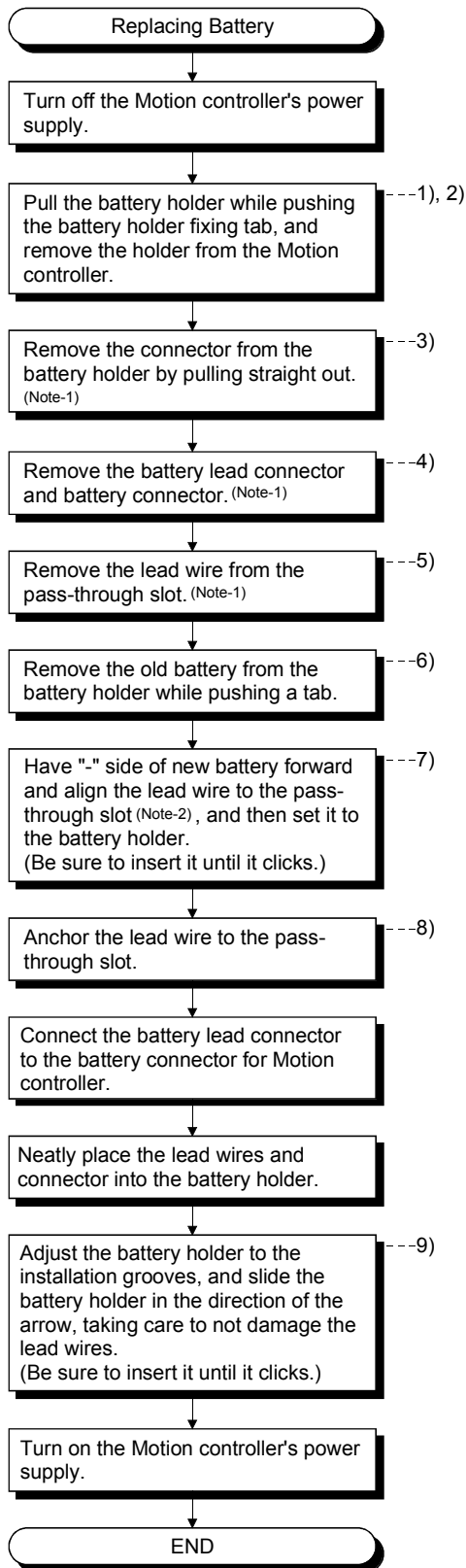

(Note-1): Do not pull on the lead wire forcibly to remove the connector.
 (Note-2): Tilt the battery not to hitch the lead wire to the battery holder.

6.5.3 Resuming operation after storing the Motion controller

When the operation is to be resumed after being stored with the battery removed or the battery has gone flat during storage, the contents for the data (Refer to Section 6.5) of RAM built-in Motion controller cannot be guaranteed.

Before resuming operation, write the contents for the data backed up prior to storage to RAM built-in Motion controller.

POINT

Before storing the Motion controller, always back up the contents for the data to RAM built-in Motion controller.

6.6 Troubleshooting

This section describes the various types of trouble that occur when the system is operated, and causes and corrective actions of these troubles.

6.6.1 Troubleshooting basics

The basic three points that must be followed in the troubleshooting are as follows.

(1) Visual inspection

Visually check the following.

- (a) Movement of machine (stopped condition, operating condition)
- (b) Power supply on/off
- (c) Status of input/output devices
- (d) Installation condition of the Motion controller, I/O module, Motion module, intelligent function module, SSCNETIII cable, Synchronous encoder cable.
- (e) State of wiring (I/O cables, cables)
- (f) Display states of various types of indicators
 - MODE LED, RUN LED, ERR. LED, BAT LED, 7-segment LED (Installation mode, Operation mode, Battery error, STOP/RUN, etc.), etc.
- (g) Status of setting of various types of switches (Setting of No. of stages of extension base unit, power interrupt hold-on status).

After checking (a) to (g), monitor the operating conditions of servomotors and error code using MT Developer2 and GX Developer.

(2) Check of trouble

Check to see how the operating condition varies while the Motion controller is operated as follows.

- (a) Set the RUN/STOP/RESET switch of Motion controller to STOP.
- (b) Reset the trouble with the RUN/STOP/RESET switch of Motion controller.
- (c) Turn ON and OFF the Motion controller's power supply.

(3) Narrowing down the range of trouble occurrence causes

Estimate the troubled part in accordance with items (1) and (2) above.

- (a) Motion controller or external devices
- (b) Motion CPU area or PLC CPU area
- (c) I/O module or others
- (d) Servo program or Motion SFC program
- (e) Sequence program

6.6.2 Troubleshooting of Motion controller

This section describes the contents of troubles for the error codes and corrective actions of the troubles.

As for troubleshooting of PLC CPU area, refer to the QCPU User's Manual (Hardware Design, Maintenance and Inspection) of their respective modules.

As for troubleshooting of I/O modules, refer to the "I/O Module Type Building Block User's Manual" of their respective modules.

POINT

Check that the operating system software is installed before starting the Motion controller.
--

(1) Troubleshooting flowchart

The followings show the contents of the troubles classified into a variety of groups according to the types of events.

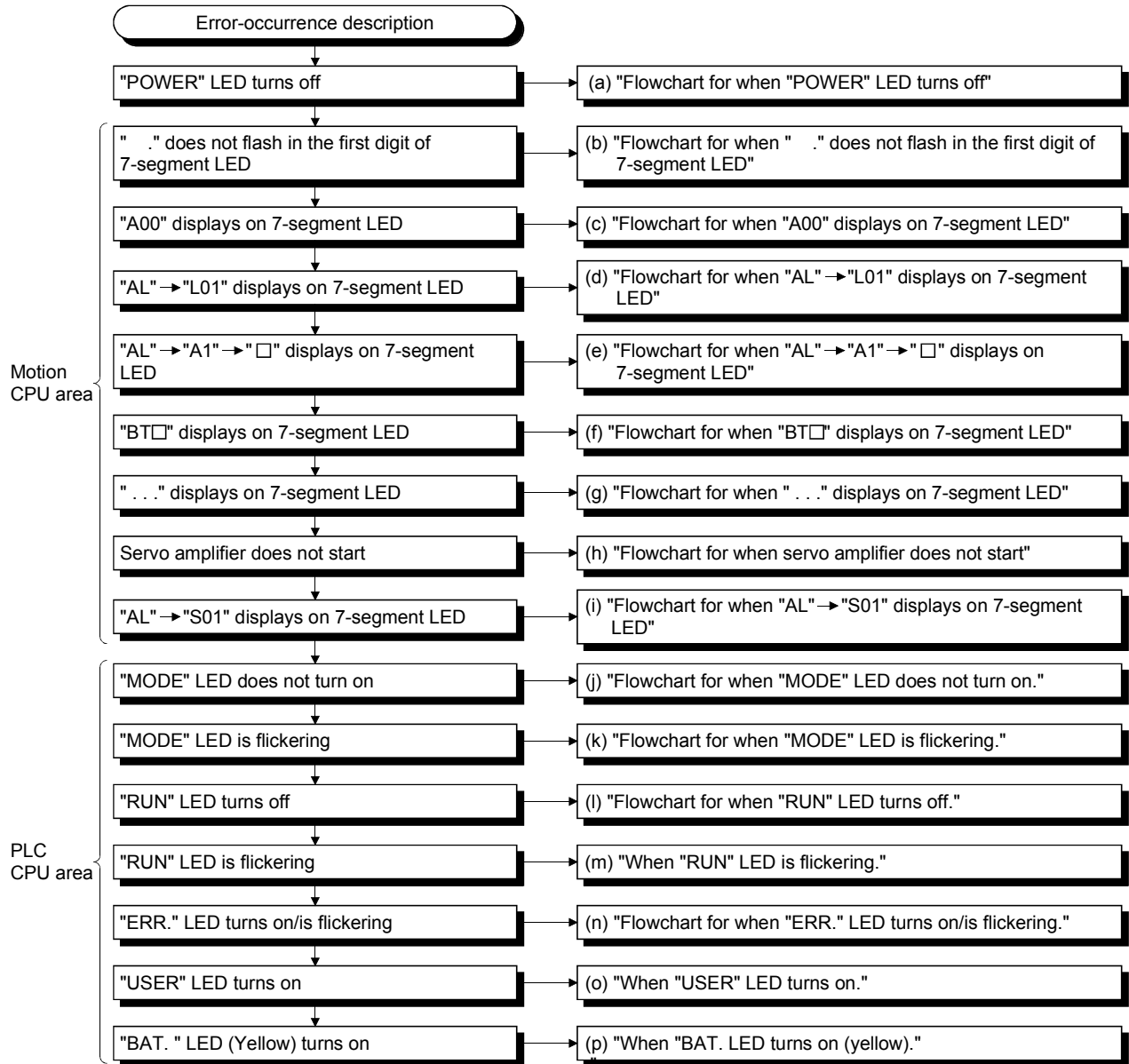

(a) Flowchart for when "POWER" LED turns off

The following shows the flowchart for when "POWER" LED turns off at the power supply ON or during operation.

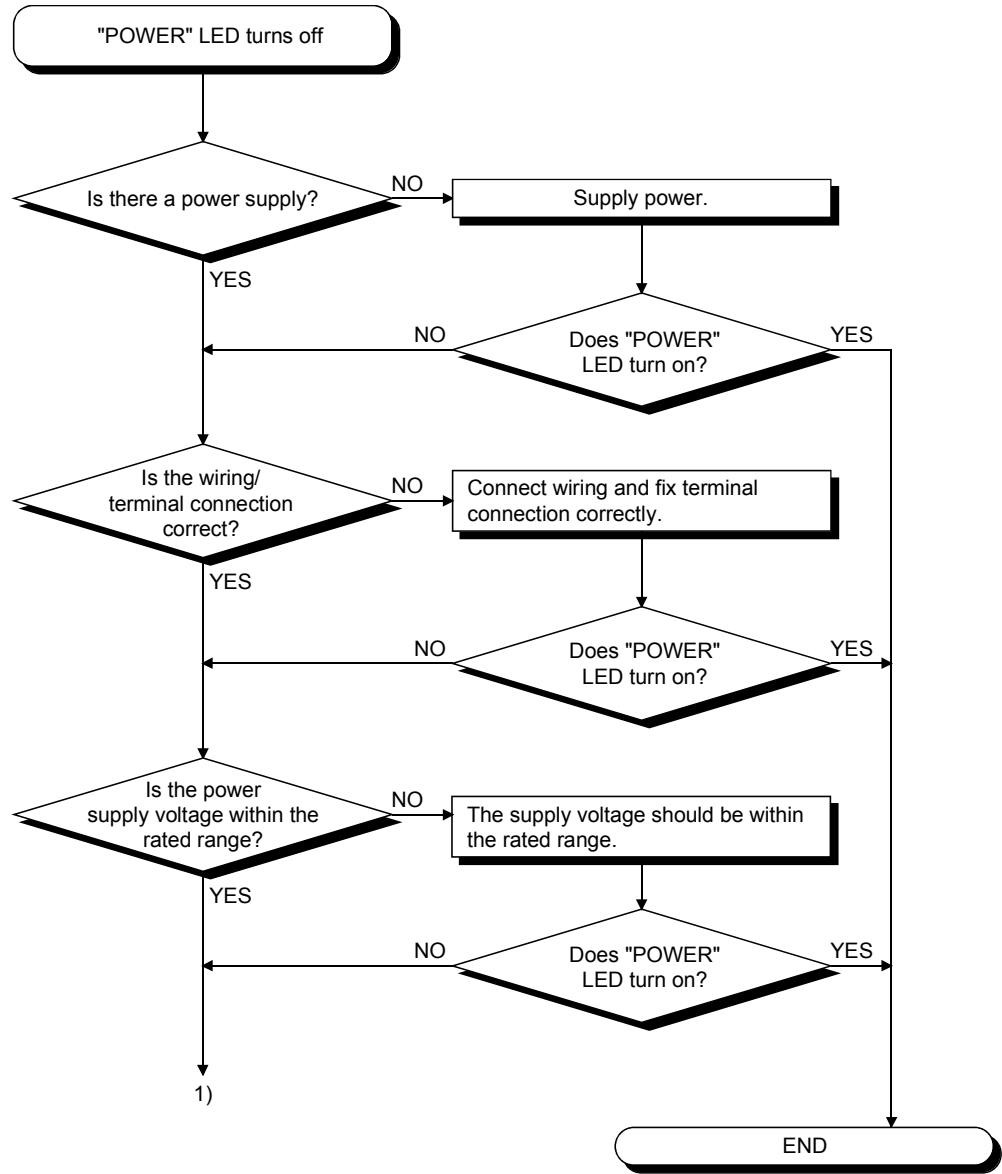

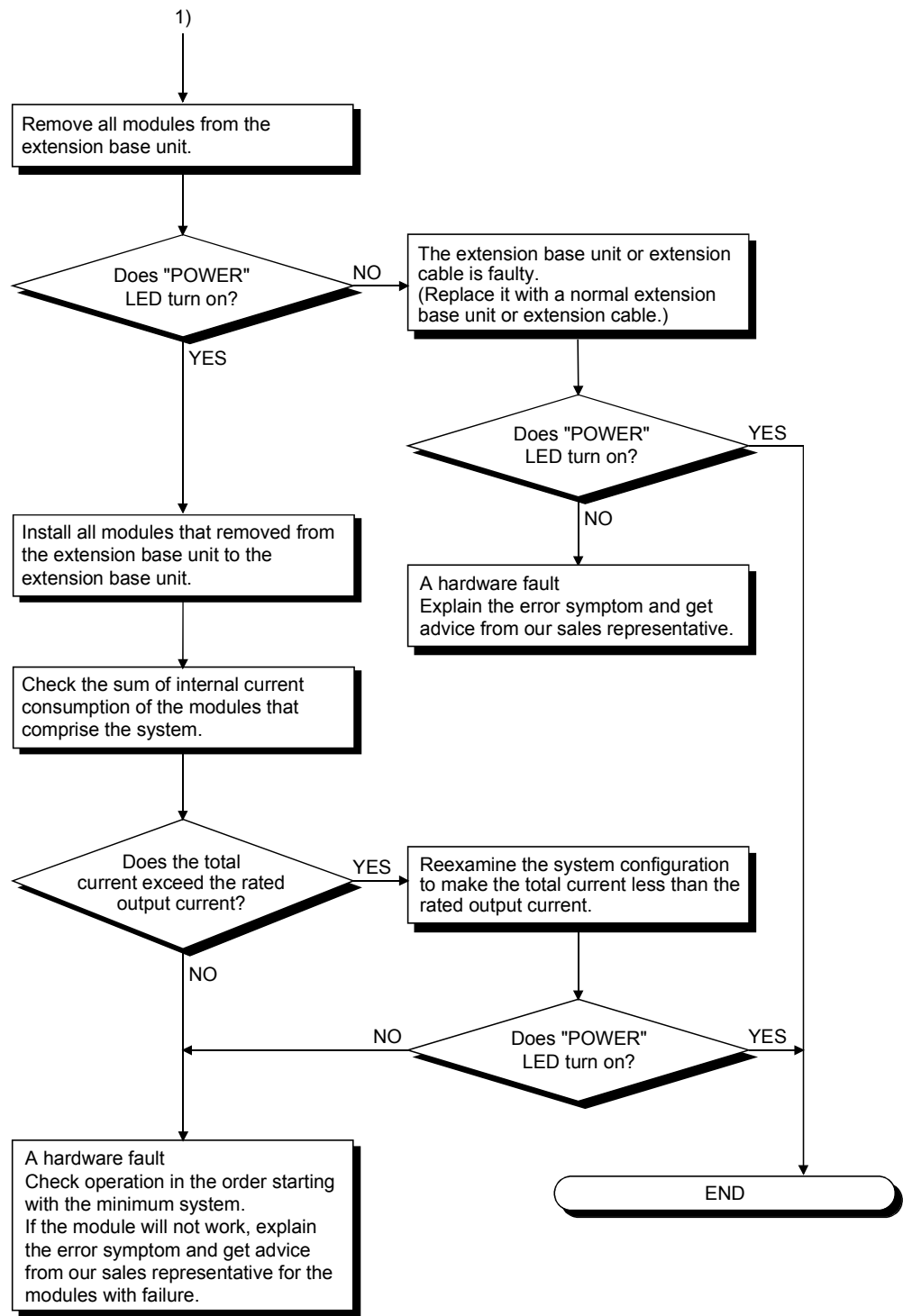

(b) Flowchart for when "." does not flash in the first digit of 7-segment LED

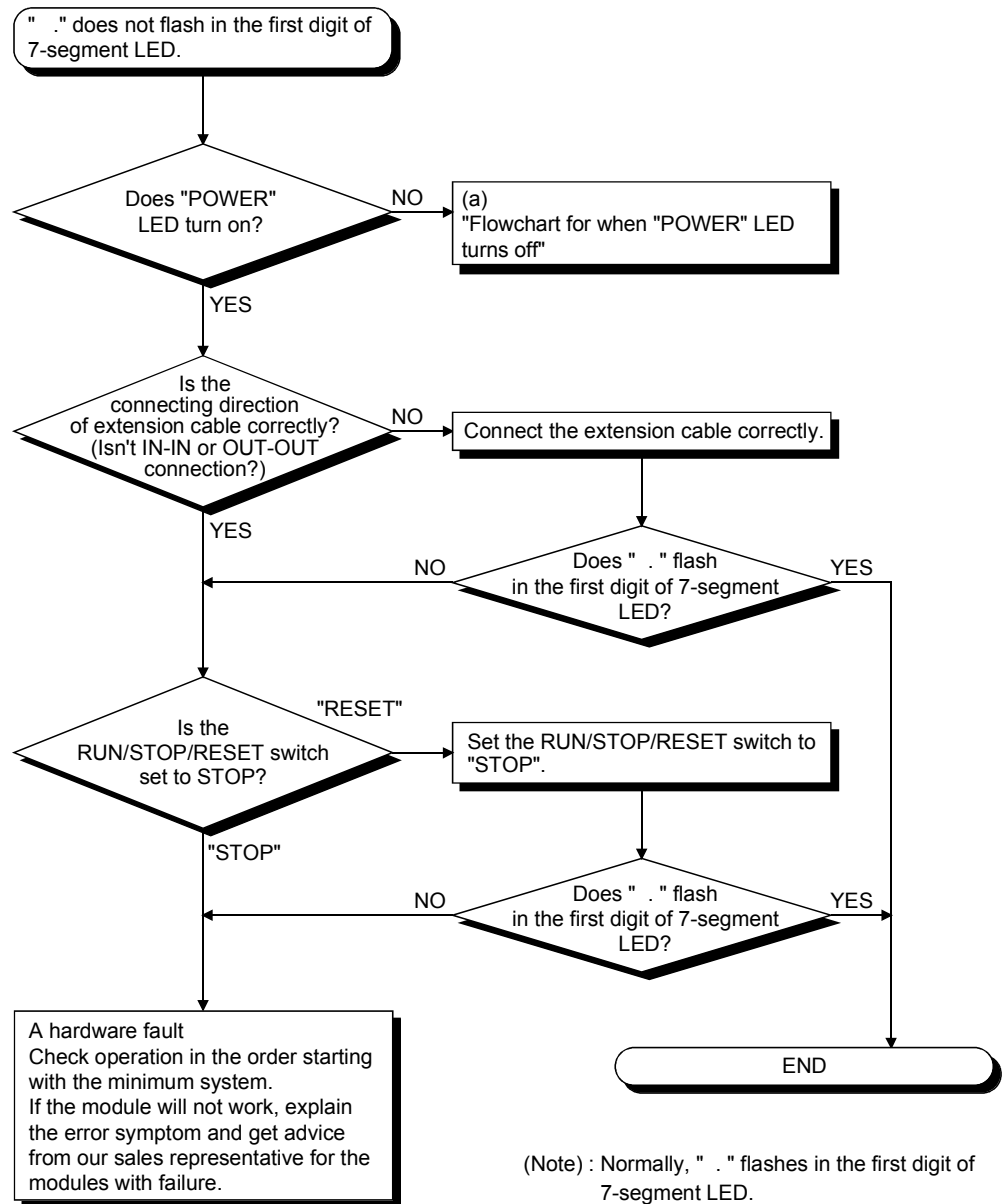

(c) Flowchart for when "A00" displays on 7-segment LED

"A00" displays when the operating system software is not installed.
The following shows the flowchart for when "A00" displays on 7-segment LED at the power supply ON or operation start.

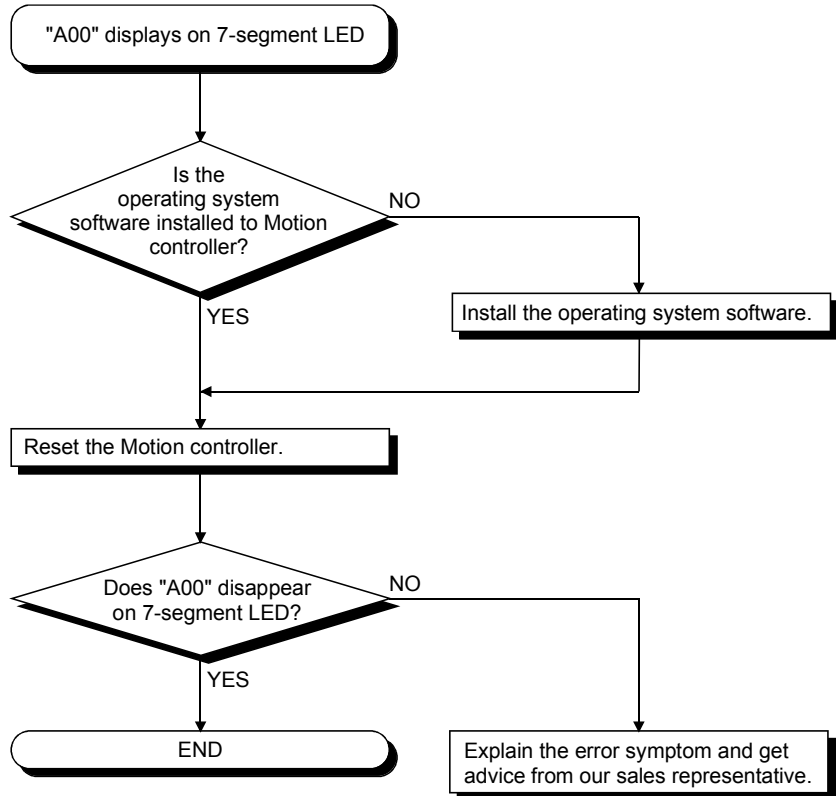

(d) Flowchart for when "AL" → "L01" displays on 7-segment LED

"AL" (flashes 3 times) → Steady "L01" display" displays at the system setting error occurrence.

The following shows the flowchart for when ""AL" (flashes 3 times) → Steady "L01" display" displays during operation.

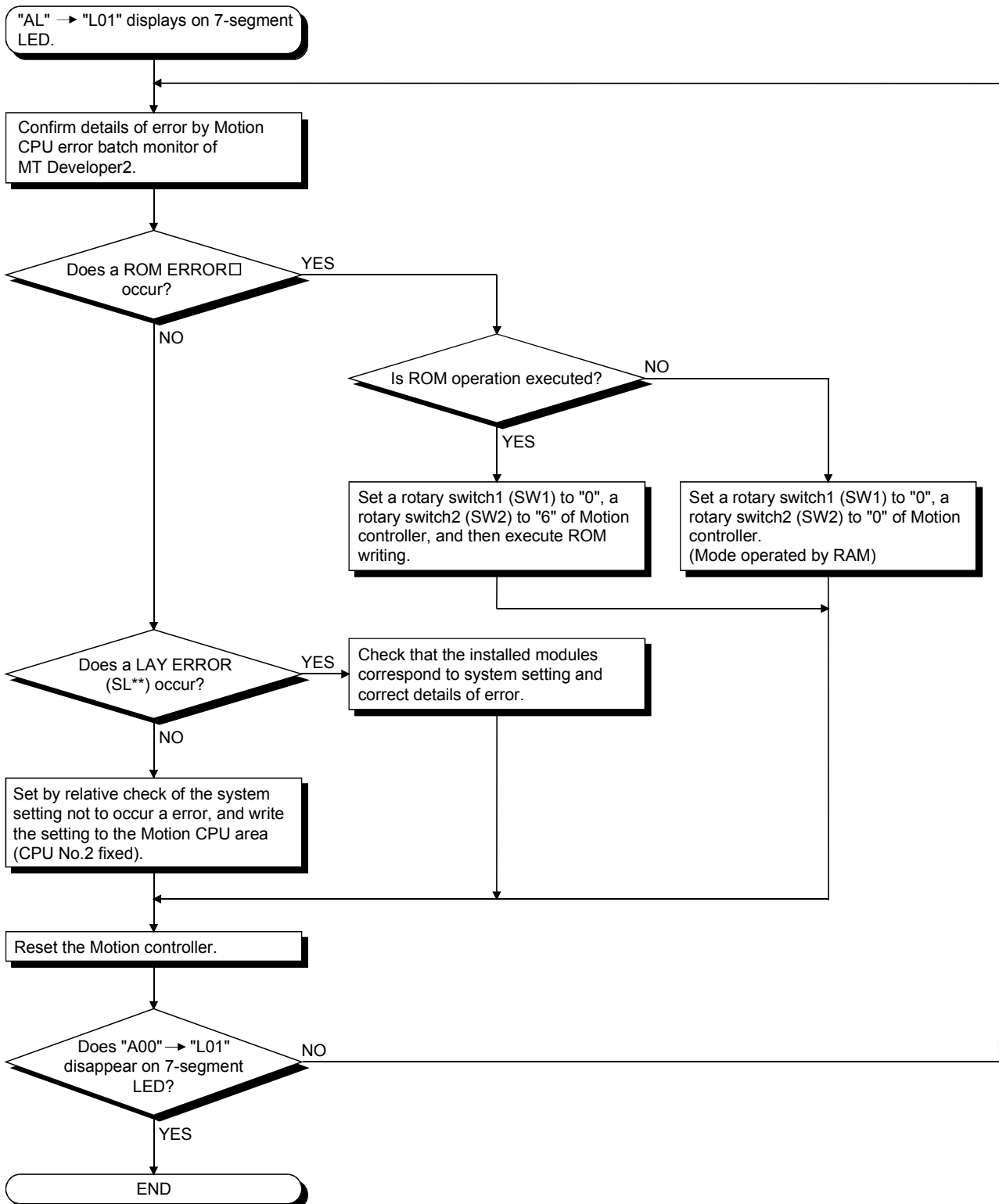

(e) Flowchart for when "AL" → "A1" → "□" displays on 7-segment LED.

"AL" (flashes 3 times) → Steady "A1" display → "□" displays at the self-diagnosis error occurrence.

The following shows the flowchart for when "AL" (flashes 3 times) → Steady "A1" display → "□" displays during operation.

□: 4-digits error code is displayed in two sequential flashes of 2-digits each.

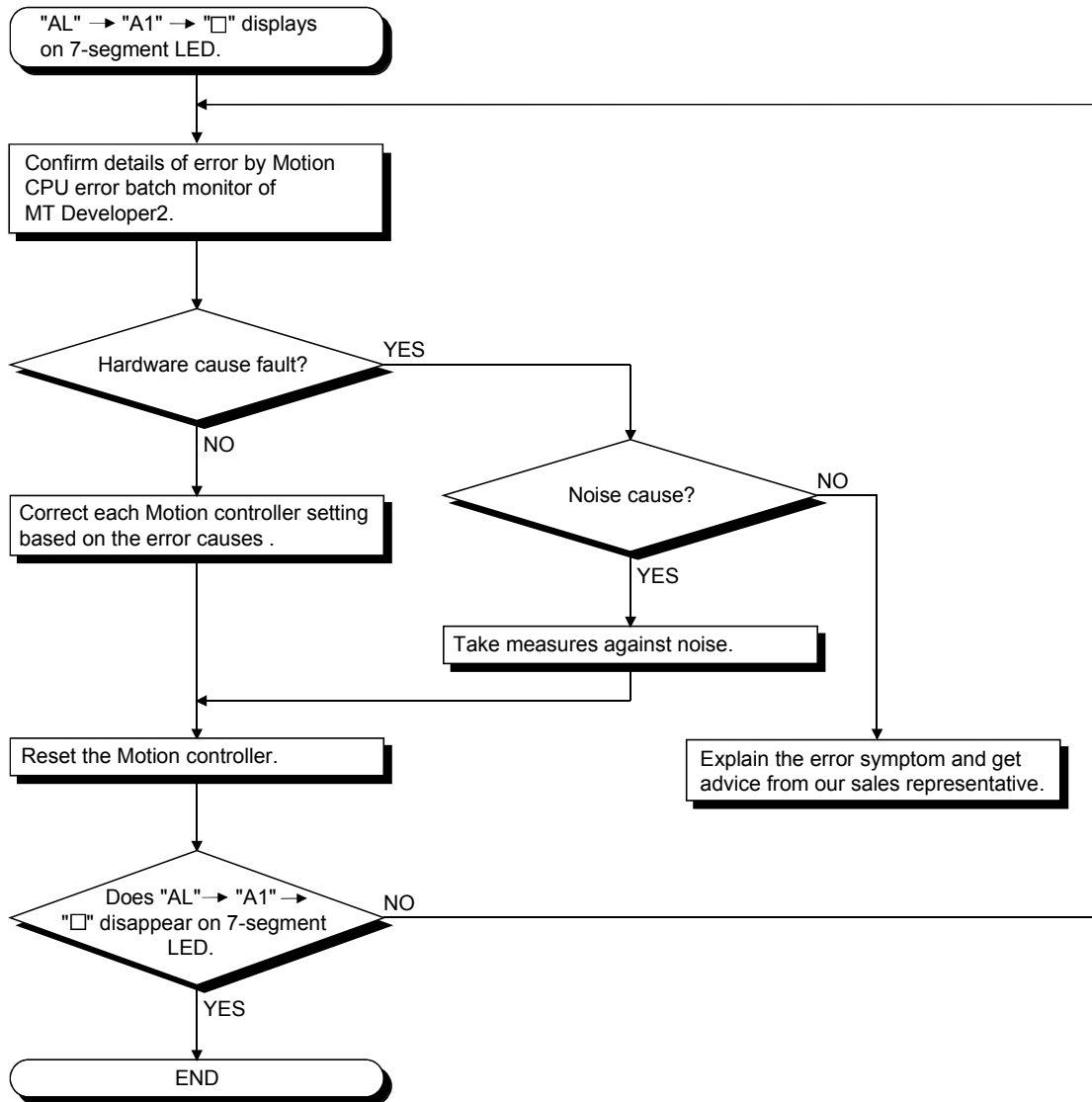

(f) Flowchart for when "BT□" displays on 7-segment LED

"BT1" or "BT1" displays when the battery voltage is lowered.

"BT1" or "BT1" displays at the following cases.

- BT1: Battery voltage 2.7V or less
- BT2: Battery voltage 2.5V or less

The following shows the flowchart for when "BT□" displays.

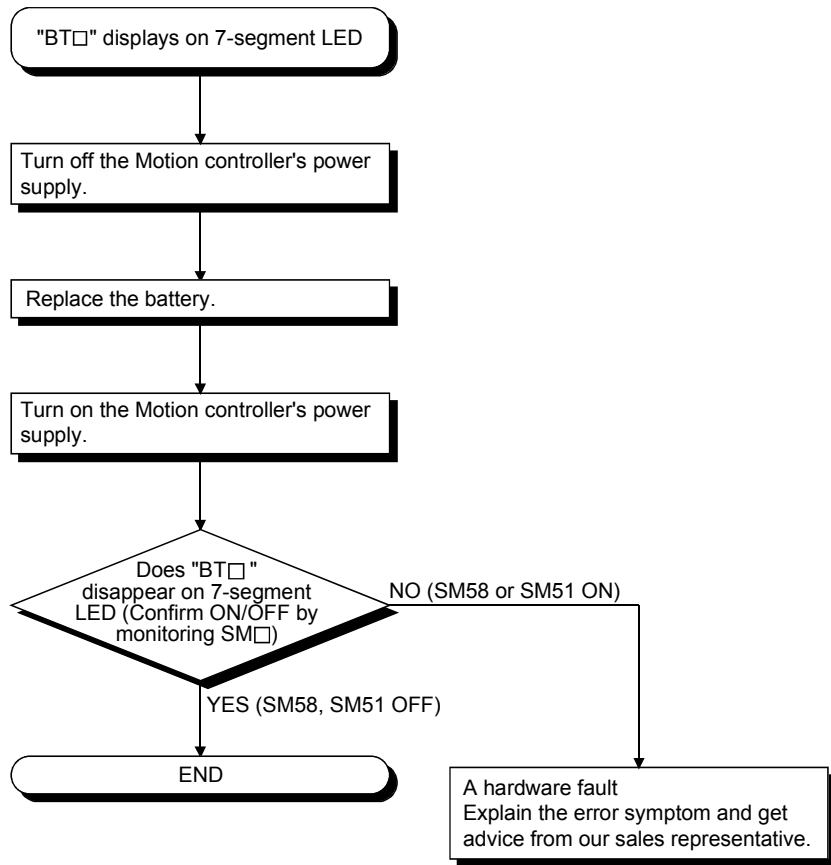

REMARK

If SM51 turns on, the contents for the data (Refer to Section 6.5.) of RAM built-in Motion controller cannot be guaranteed.

It is recommended to back-up the battery periodically.

(g) Flowchart for when ". . ." displays on 7-segment LED

". . ." displays at the WDT error occurrence.

The following shows the flowchart for when ". . ." displays on 7-segment LED during operation.

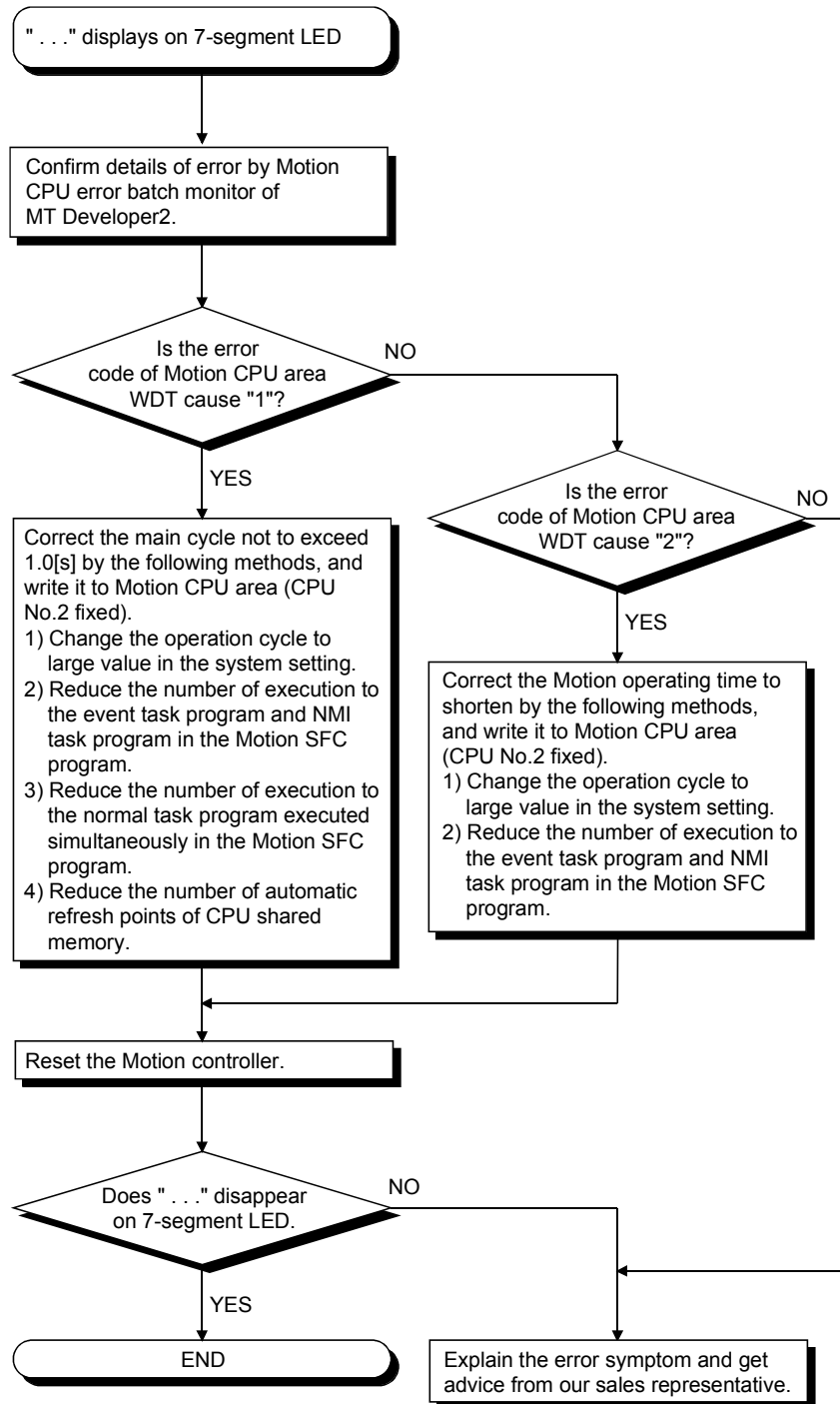

(h) Flowchart for when servo amplifier does not start

The following shows the flowchart for when servo amplifier does not start.

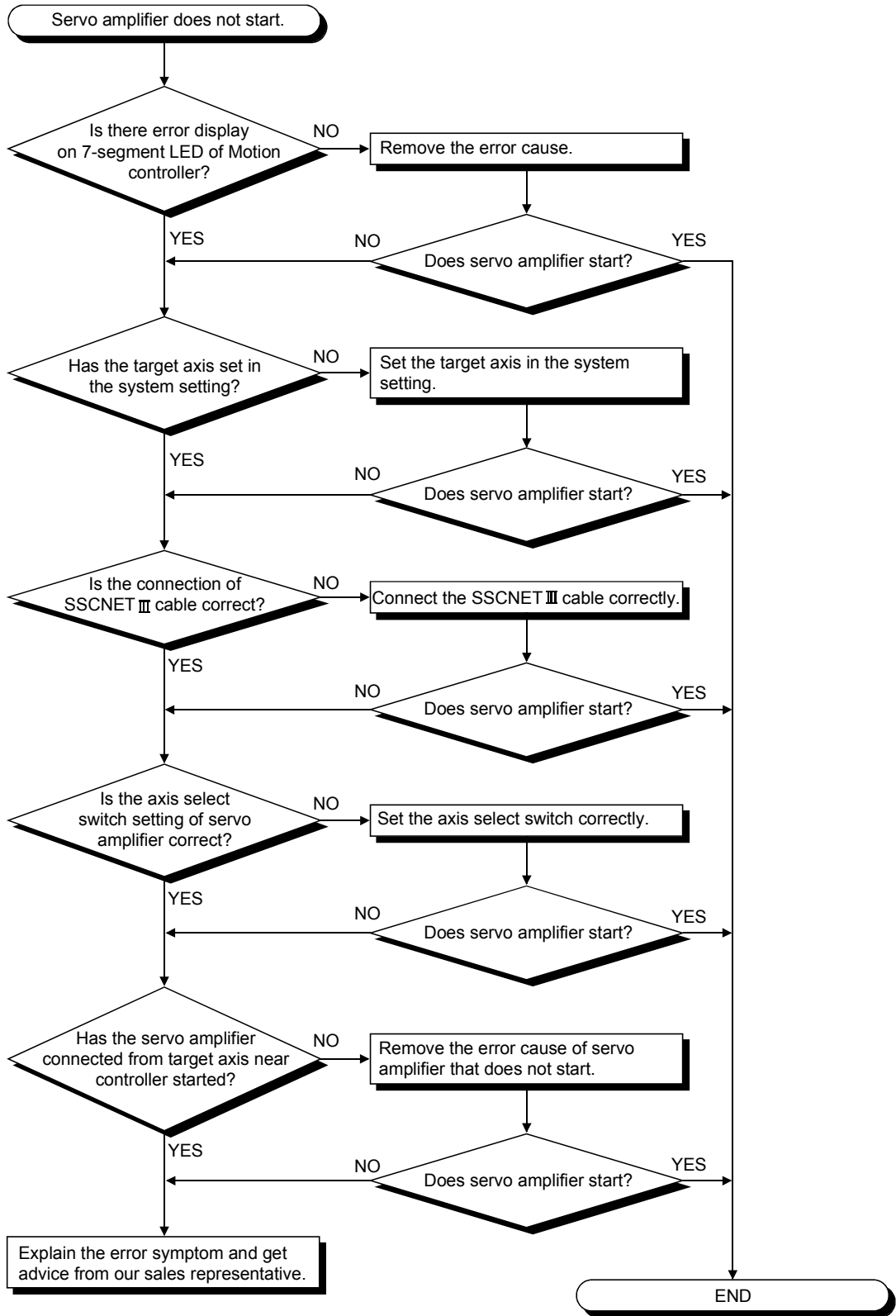

(i) Flowchart for when "AL" → "S01" displays on 7-segment LED

"AL" (flashes 3 times) → Steady "S01" display" displays at the servo error occurrence.

The following shows the flowchart for when "AL" (flashes 3 times) → Steady "S01" display" displays on 7-segment LED during operation.

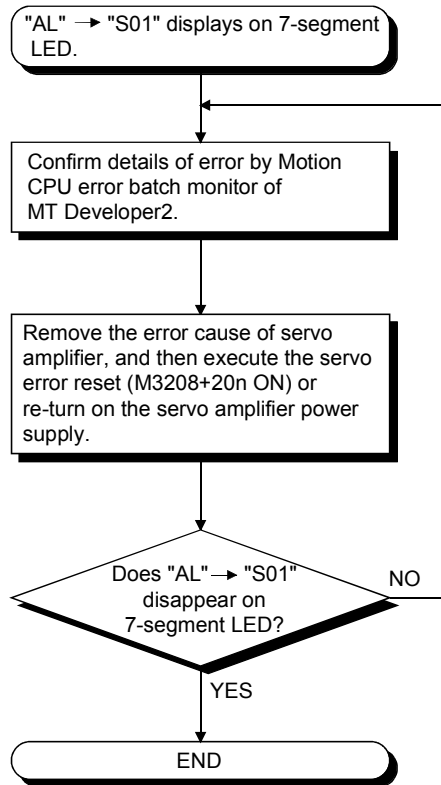

(j) Flowchart for when "MODE" LED does not turn on

The following shows the flowchart for when "MODE" LED does not turn on at Motion controller's power-on.

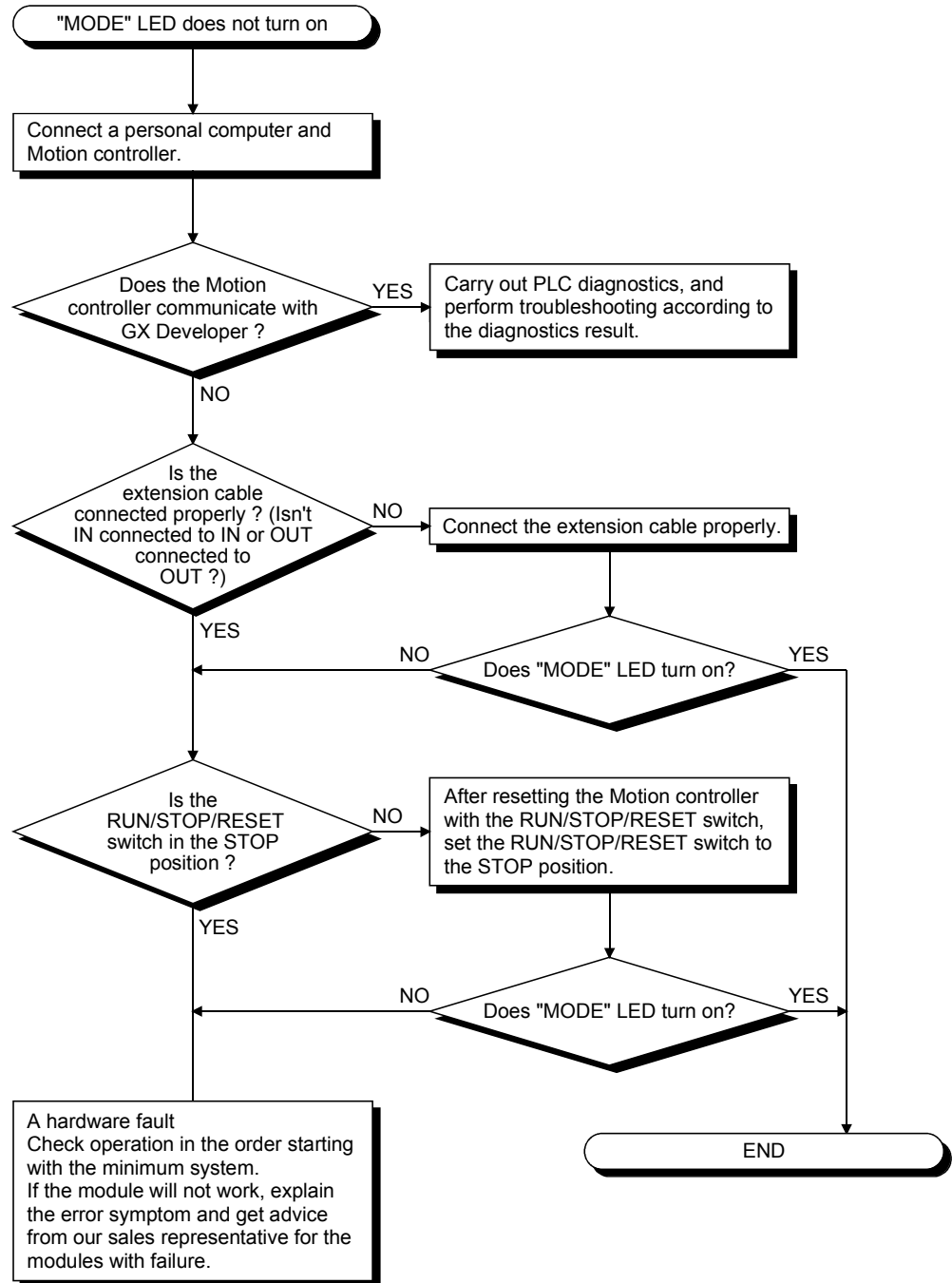

(k) Flowchart for when "MODE" LED is flickering

The following shows the flowchart for when "MODE" LED flickers at Motion controller's power-on, at operation start or during operation.

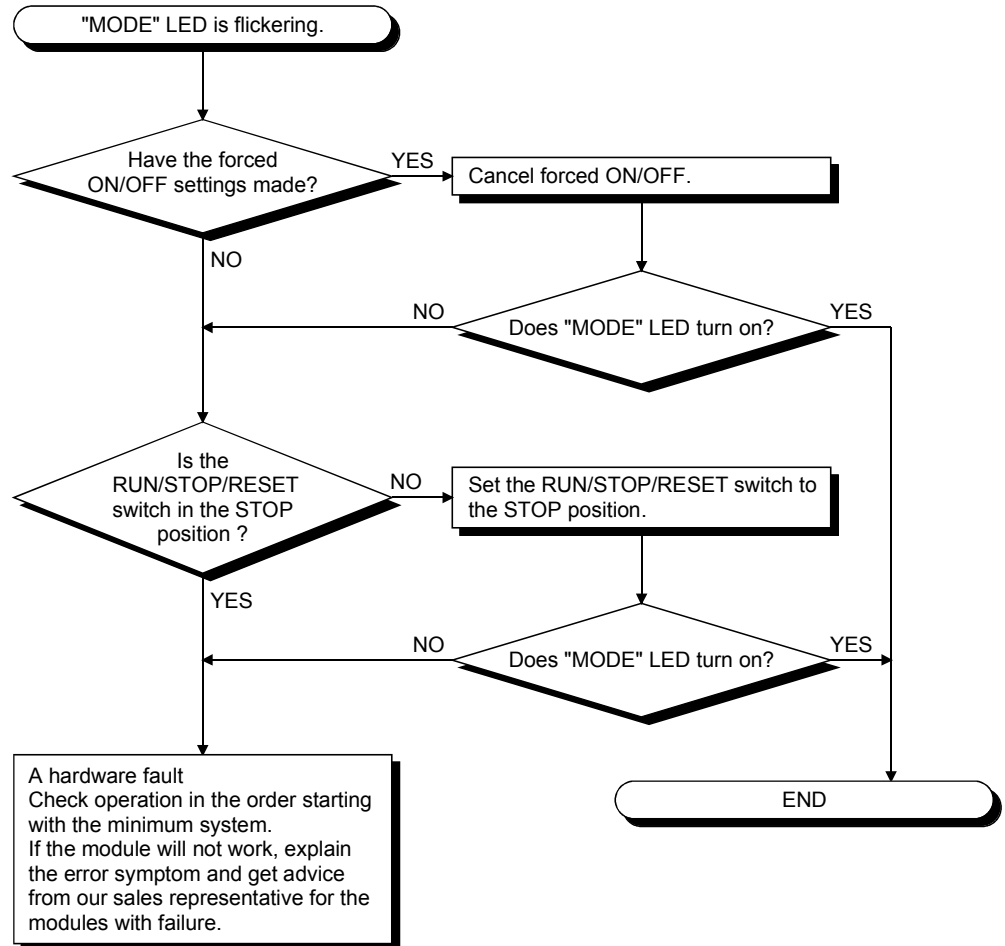

(I) Flowchart for when "RUN" LED turns off

The following shows the flowchart for when "RUN" LED turns off during operation.

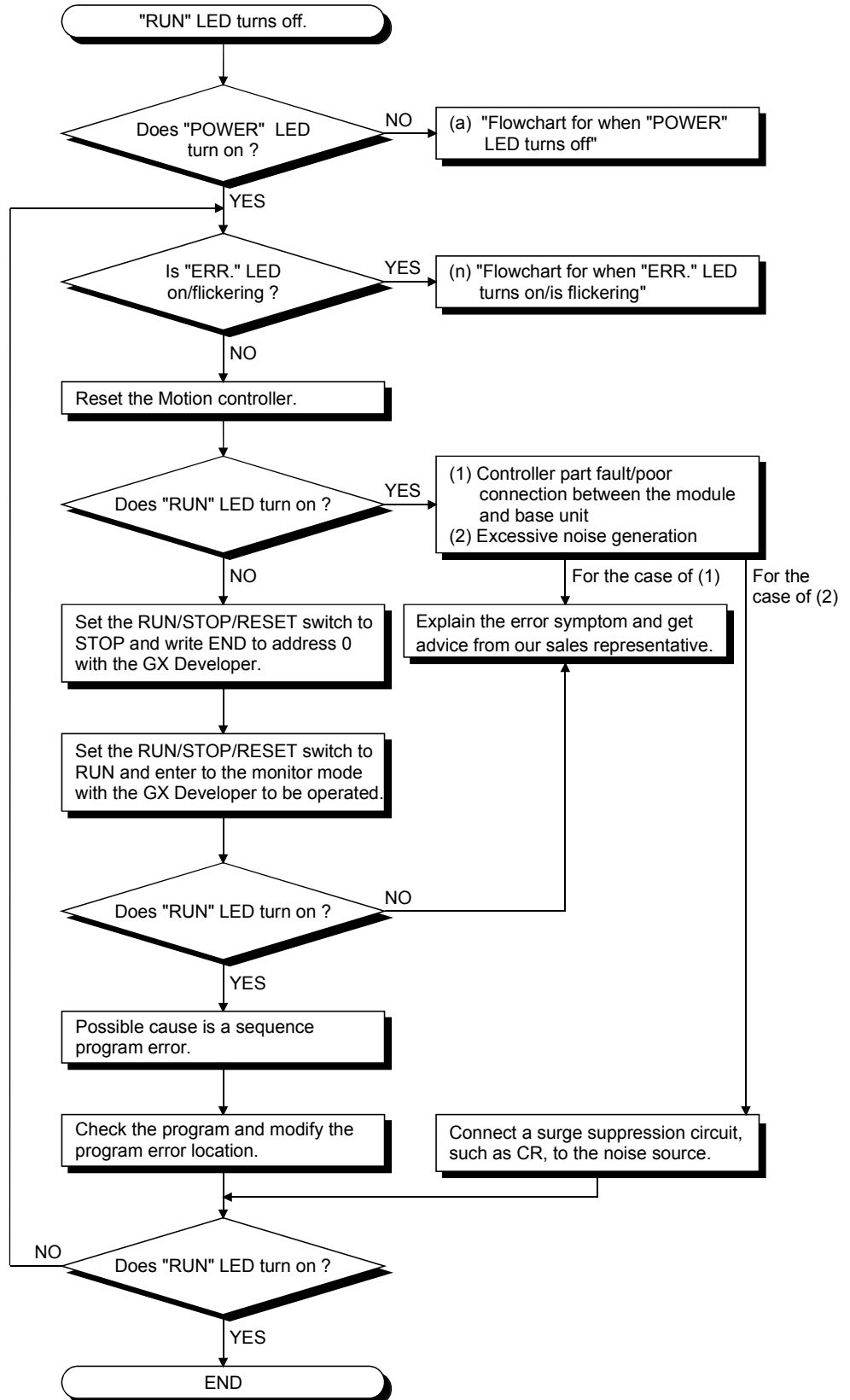

(m) When "RUN" LED is flickering

If the "RUN" LED flickers, follow the steps below.

When the programs or parameters are written into the Motion controller during STOP status and then the RUN/STOP/RESET switch is set from STOP to RUN, the RUN LED flickers.

Although this status does not mean the Motion controller error, the Motion controller stops the operation. To set the Motion controller into RUN status, reset the Motion controller using the RUN/STOP/RESET switch or set the RUN/STOP/RESET switch from STOP to RUN again.

With this setting, the RUN LED turns on.

(n) Flowchart for when "ERR." LED turns on/is flickering

The following shows the flowchart for when "ERR." LED turns on or flickers at Motion controller's power-on, at operation start or during operation.

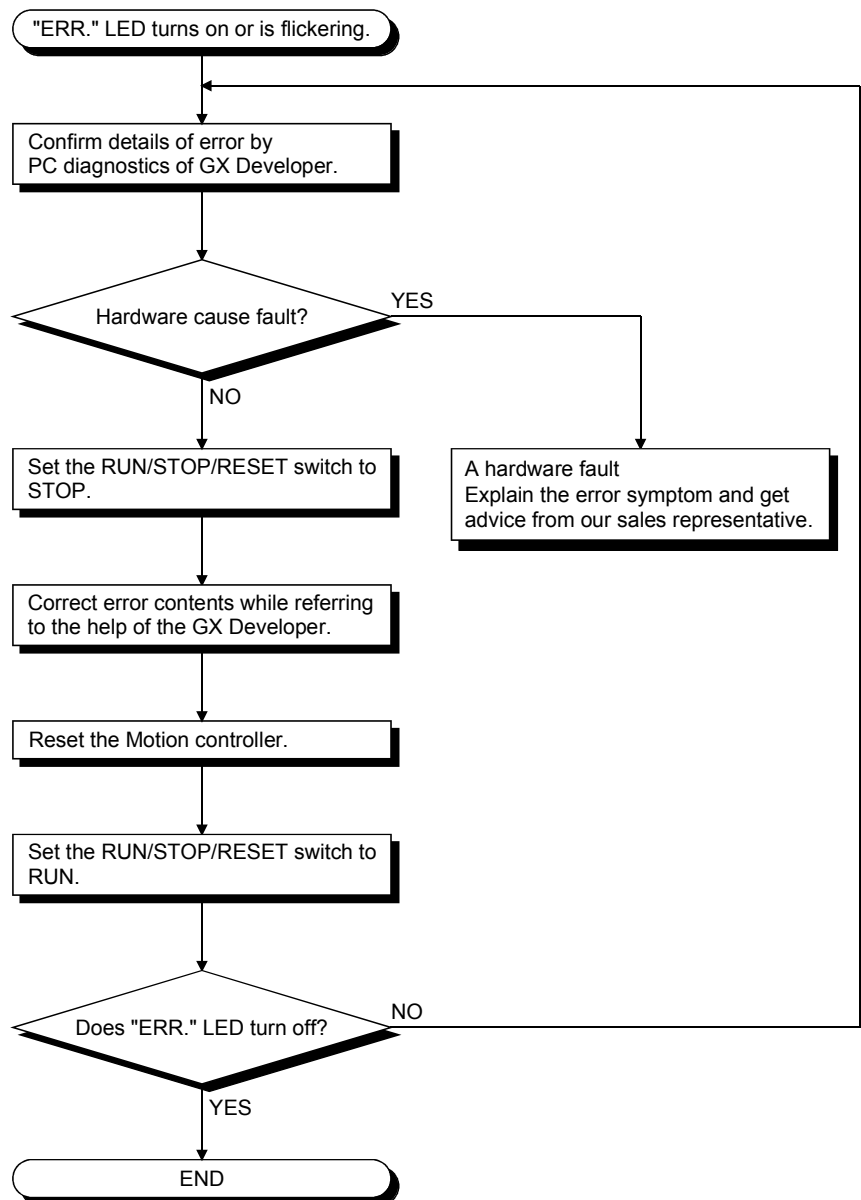

(o) When "USER" LED turns on

If the "USER" LED turns on, follow the steps described below.

"USER" LED turns on when an error is detected by the CHK instruction or the annunciator (F) turns on.

If "USER" LED is on, monitor the special relays SM62 and SM80 in the monitor mode of GX Developer.

- When SM62 has turned ON
The annunciator (F) is ON.
Using SD62 to SD79, check the error cause.
- When SM80 has turned ON
The "USER" LED turned ON by the execution of the CHK instruction.
Using SD80, check the error cause.

Eliminate the error cause after confirming it.

The "USER" LED can be turned off by:

- Making a reset with the RUN/STOP/RESET switch; or
- Executing the LEDR instruction in the sequence program.

(p) When "BAT." LED turns on (yellow)

If "BAT." LED turns on (yellow), follow the steps described below.

"BAT." LED turns on (yellow) when a low battery capacity is detected.

If the "BAT." LED is on, monitor the special relays and special registers in the monitor mode of GX Developer to check which of the SRAM card batteries was lowered in capacity. (SM51 to SM52, SD51 to SD52)

After confirmation, replace the battery with a new one, and reset the Motion controller with the RUN/STOP/RESET switch or run the LEDR instruction, and the "BAT." LED will turn off.

6.6.3 Confirming error code

The error codes and error contents can be read using GX Developer and MT Developer2.

Refer to the Operating Manual of GX Developer and help of MT Developer2 for details of operating method.

7 POSITIONING DEDICATED SIGNALS

7. POSITIONING DEDICATED SIGNALS

The usable devices in Motion controller (Q170MCP) are shown below.

7.1 Device List

Table 7.1 Device list

Direction	Device		Points	Operating range	
	Name	Code			
Bit devices	Input	X	8192	X0 to X1FFF	Hexadecimal
	Output	Y	8192	Y0 to Y1FFF	Hexadecimal
	Actual input	PX	256	PX0 to PXFFF ^(Note-1)	Hexadecimal
	Actual output	PY	256	PY0 to PYFFF ^(Note-1)	Hexadecimal
	Internal relay	M	12288	M0 to M12287	Decimal
	Link relay	B	8192	B0 to B1FFF	Hexadecimal
	Annunciator	F	2048	F0 to F2047	Decimal
	Special relay	SM	2256	SM0 to SM2255	Decimal
Word devices	Data register	D	8192	D0 to D8191	Decimal
	Link register	W	8192	W0 to W1FFF	Hexadecimal
	Motion register	#	12288	#0 to #12287	Decimal
	Special register	SD	2256	SD0 to SD2255	Decimal
	Coasting timer	FT	1	FT	Decimal

(Note-1): 256 points are usable in the operating range.

7 POSITIONING DEDICATED SIGNALS

7.2 Positioning Dedicated Signals

The device list of positioning dedicated signals is shown below.
Refer to the following manuals for details of positioning dedicated signals.

Manual Name	Manual Number
Q173DCPU/Q172DCPU Motion controller Programming Manual (COMMON)	IB-0300134
Q173DCPU/Q172DCPU Motion controller Programming Manual (Motion SFC)	IB-0300135
Q173DCPU/Q172DCPU Motion controller Programming Manual (REAL MODE)	IB-0300136
Q173DCPU/Q172DCPU Motion controller Programming Manual (VIRTUAL MODE)	IB-0300137

7.2.1 Internal Relays

Table 7.2 Internal relay list

SV13		SV22	
Device No.	Application	Device No.	Application
M0 to	User device (2000 points)	M0 to	User device (2000 points)
M2000 to	Common device (320 points)	M2000 to	Common device (320 points)
M2320 to	Unusable (80 points)	M2320 to	Unusable (80 points)
M2400 to	Axis status (20 points × 16 axes)	M2400 to	Axis status (20 points × 16 axes) Real mode.....Each axis Virtual mode....Output module
M2720 to	User device (320 points) ^(Note-1)	M2720 to	User device (320 points) ^(Note-1)
M3040 to	Unusable (32 points)	M3040 to	Unusable (32 points)
M3072 to	Common device (Command signal) (64 points)	M3072 to	Common device (Command signal) (64 points)
M3136 to	Unusable (64 points)	M3136 to	Unusable (64 points)
M3200 to	Axis command signal (20 points × 16 axes)	M3200 to	Axis command signal (20 points × 16 axes) Real mode.....Each axis Virtual mode....Output module
M3520 to M3839	User device (320 points) ^(Note-1)	M3520 to M3839	User device (320 points) ^(Note-1)

7 POSITIONING DEDICATED SIGNALS

SV13		SV22	
Device No.	Application	Device No.	Application
M3840	User device (4352 points)	M3840 to	Unusable (160 points)
		M4000 to	Virtual servo motor axis status (20 points × 16 axes) ^{(Note-2), (Note-3)}
		M4320 to	User device (320 points) ^(Note-1)
		M4640 to	Synchronous encoder axis status (4 points × 8 axes) ^(Note-3)
		M4672 to	Unusable (128 points) ^(Note-2)
		M4800 to	Virtual servo motor axis command signal (20 points × 16 axes) ^{(Note-2), (Note-3)}
		M5120 to	User device (320 points) ^(Note-1)
		M5440 to	Synchronous encoder axis command signal (4 points × 8 axes) ^(Note-3)
		M5472 to	Unusable (16 points) ^(Note-2)
		M5488 to	User device (2704 points) ^(Note-4)
M8192 to M12287	Unusable (4096 points)	M8192 to M12287	Unusable (4096 points)

It can be used as an user device.

(Note-1): When extending it to the system more than 17 axes in Q17□DCPU/Q17□HCPU(-T)/
Q17□CPUN(-T)/Q17□CPU, this device is recommended not to be used.

(Note-2): It can be used as an user device in the SV22 real mode only.

(Note-3): Do not set M4000 to M5487 as the latch range in virtual mode.

(Note-4): The cam axis command signal and smoothing clutch complete signal can be set as the optional
device at the parameter.

POINT
<ul style="list-style-type: none"> Total number of user device points
<div style="border: 1px solid black; padding: 2px; display: inline-block;"> 6352 points (SV13) / 4704 points ^(Note) (SV22) </div>
(Note): Up to 6096 points can be used when not using it in the virtual mode.

7 POSITIONING DEDICATED SIGNALS

7.2.2 Data Registers

Table 7.3 Data register list

SV13		SV22	
Device No.	Application	Device No.	Application
D0 to	Axis monitor device (20 points × 16 axes)	D0 to	Axis monitor device (20 points × 16 axes) Real mode.....each axis Virtual mode....output module
D320 to	User device (320 points) ^(Note-1)	D320 to	User device (320 points) ^(Note-1)
D640 to	Control change register (2 points × 16 axes)	D640 to	Control change register (2 points × 16 axes)
D672 to	Unusable (32 points)	D672 to	Unusable (32 points)
D704 to	Common device (Command signal) (54 points)	D704 to	Common device (Command signal) (54 points)
D758 to	Unusable (42 points)	D758 to	Unusable (42 points)
D800 to D8191	 User device (7392 points)	D800 to	Virtual servo motor axis monitor device (10 points × 16 axes) ^(Note-2)
		D960 to	User device (160 points) ^(Note-1)
		D1120 to	Synchronous encoder axis monitor device (10 points × 8 axes)
		D1200 to	Unusable (40 points)
		D1240 to	CAM axis monitor device (10 points × 16 axes) ^(Note-2)
		D1400 to	User device (160 points) ^(Note-1)
		D1560 to D8191	User device (6632 points)

It can be used as an user device.

(Note-1): When extending it to the system more than 17 axes in Q17□DCPU/Q17□HCPU(-T)/
Q17□CPUN(-T)/Q17□CPU, this device is recommended not to be used.

(Note-2): It can be used as an user device in the SV22 real mode only.

POINT
• Total number of user device points 7392 points (SV13) / 6632 points ^(Note) (SV22)
(Note): Up to 7272 points can be used when not using it in the virtual mode.

7 POSITIONING DEDICATED SIGNALS

7.2.3 Motion Registers

Table 7.4 Motion register list

Device No.	Application
#0 to	User device (8000 points)
#8000 to	Monitor device (640 points)
#8640 to	Motion error history device (96 points)
#8736 to #12287	Unusable (3552 points)

It can be used as a user device.

7.2.4 Special Relays

Table 7.5 Special relay list

Device No.	Application
SM0 to	System device (2000 points)
SM2000 to SM2255	System device (For replacement) ^(Note-1) (256 points)

(Note-1): For replacement from a project of Q17□HCPU(-T)/Q17□CPUN(-T)/Q17□CPU to the project of Q170MCPU.

Refer to the "Q173DCPU/Q172DCPU Motion controller Programming Manual (COMMON)
"APPENDIX 1.3 Replacement of special relays/special registers"" for details.

7.2.5 Special Registers

Table 7.6 Special register list

Device No.	Application
SD0 to	System device (2000 points)
SD2000 to SD2255	System device (For replacement) ^(Note-1) (256 points)

(Note-1): For replacement from a project of Q17□HCPU(-T)/Q17□CPUN(-T)/Q17□CPU to the project of Q170MCPU.

Refer to the "Q173DCPU/Q172DCPU Motion controller Programming Manual (COMMON)
"APPENDIX 1.3 Replacement of special relays/special registers"" for details.

APPENDICES

APPENDIX 1 Differences Between Q170MCPU and Q173DCPU/Q172DCPU

This section describes the differences between Q170MCPU and Q173DCPU/Q172DCPU, and the contents of change.

Refer to the following manuals for contents in common with Q173DCPU/Q172DCPU.

Manual name	Manual number
Q173DCPU/Q172DCPU Motion controller Programming Manual (COMMON)	IB-0300134
Q173DCPU/Q172DCPU Motion controller (SV13/SV22) Programming Manual (Motion SFC)	IB-0300135
Q173DCPU/Q172DCPU Motion controller (SV13/SV22) Programming Manual (REAL MODE)	IB-0300136
Q173DCPU/Q172DCPU Motion controller (SV22) Programming Manual (VIRTUAL MODE)	IB-0300137

APPENDIX 1.1 Differences of devices

Table 1.1 Differences of devices

Device No.		Name	Description	Remark												
Q170MCP	Q173DCPU/ Q172DCPU															
D12+20n	D12+20n	Execute program No. storage register	This register stores the starting program No. at the servo program starting. <ul style="list-style-type: none"> • FFFFJOG operation • FFFE Manual pulse generator operation • FF00 Power supply ON • FFE0 Current value change execution by the Motion dedicated instruction 	Add "FFE0".												
#8000+20n	#8000+20n	Servo amplifier type	This register stores the servo amplifier type for each axis at the servo amplifier power supply ON. <ul style="list-style-type: none"> • 0 Unused • 256 MR-J3-□B MR-J3-□B (For 2-axis type) • 257 MR-J3-□B (For fully closed loop control) • 258 MR-J3-□B (For Linear control) • 263 MR-J3-□B (For direct drive motor) It is not cleared even if the servo amplifier power supply turns OFF.	Add "263".												
#8008+20n	—	Servo amplifier display servo error code	This register stores the servo error code read from the servo amplifier. The hexadecimal display is the same as the LED of servo amplifier. Refer to the "Servo amplifier Instruction Manual" for details of the servo error codes.	New												
SD720, SD721	—	444µs coasting timer	Current value (SD720, SD721) is incremented by 1 per 444µs. Read SD720 device in 2 word unit. <table border="1" style="margin-left: auto; margin-right: auto;"> <thead> <tr> <th>Item</th> <th>Specification</th> </tr> </thead> <tbody> <tr> <td>Data size</td> <td>2 word (-2147483648 to 2147483647)</td> </tr> <tr> <td>Latch</td> <td>Cleared to zero at power-on or reset, a count rise is continued from now on.</td> </tr> <tr> <td>Usable tasks</td> <td>Normal, event, NMI</td> </tr> <tr> <td>Access</td> <td>Read only enabled</td> </tr> <tr> <td>Timer specifications</td> <td>444µs timer</td> </tr> </tbody> </table>	Item	Specification	Data size	2 word (-2147483648 to 2147483647)	Latch	Cleared to zero at power-on or reset, a count rise is continued from now on.	Usable tasks	Normal, event, NMI	Access	Read only enabled	Timer specifications	444µs timer	New
Item	Specification															
Data size	2 word (-2147483648 to 2147483647)															
Latch	Cleared to zero at power-on or reset, a count rise is continued from now on.															
Usable tasks	Normal, event, NMI															
Access	Read only enabled															
Timer specifications	444µs timer															

In the device numbers, "n" in "D12+20n", etc. indicates a value corresponding to axis No. such as the following tables.

Axis No.	n	Axis No.	n	Axis No.	n	Axis No.	n
1	0	5	4	9	8	13	12
2	1	6	5	10	9	14	13
3	2	7	6	11	10	15	14
4	3	8	7	12	11	16	15

- Calculate as follows for the device No. corresponding to each axis.
(Example) For axis 16
D12+20n=D12+20×15=D312

APPENDICES

APPENDIX 1.2 Differences of parameters

Table 1.2 Differences of parameters

Item		Q170MCPU	Q173DCPU/Q172DCPU
System setting	Extension base	Stage 1Nothing 2 Slots 5 Slots GOT (Bus connection) Stage 2Nothing GOT (Bus connection)	Stage 1 to 7 Nothing 2 Slots 3 Slots 5 Slots 8 Slots 10 Slots/GOT (Bus connection) 12 slots
	Amplifier setting	[Axis No.] 1 to 16 [Amplifier type] MR-J3-B MR-J3-B Fully closed MR-J3-B Linear MR-J3-B DD motor	[Axis No.] Q173DCPU: 1 to 32 Q172DCPU: 1 to 8 [Amplifier type] MR-J3-B MR-J3-B Fully closed MR-J3-B Linear

POINT

Set "MR-J3-B" to use the MR-J3W-B.

APPENDIX 1.3 Differences of programs

Table 1.3 Differences of Motion SFC and servo programs

Program	Item	Q170MCPU	Q173DCPU/Q172DCPU
Motion SFC	Event task	Fixed cycle (0.44ms, 0.88ms, 1.77ms, 3.55ms, 7.11ms, 14.2ms).	Fixed cycle (0.88ms, 1.77ms, 3.55ms, 7.11ms, 14.2ms)
Servo program	Speed-position control	DOG/CHANGE signal of Q172DLX and external input signal (DOG) of servo amplifier can be used.	DOG/CHANGE signal of Q172DLX can be used.
	Count type home position return		

POINT



The variation for ON/OFF timing of the external input signal (DOG) of servo amplifier may occur according to the input filter setting value of external signal input setting.

Review the input filter setting value compatible with the applications.

Use the Q172DLX to execute the high-accuracy control.

APPENDICES

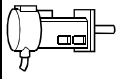
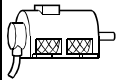
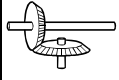
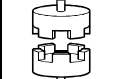
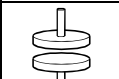
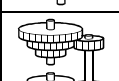
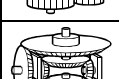
Table 1.4 Differences of mechanical system programs

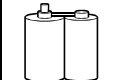
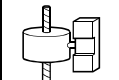
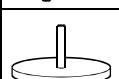
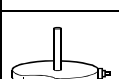
Classification	Mechanical module		Maximum number of usable											
			Q170MCPU				Q173DCPU				Q172DCPU			
	Name	Appearance	Number per Motion controller	Number per system	Number per block		Number per Motion CPU module	Number per system	Number per block		Number per Motion CPU module	Number per system	Number per block	
				Connection shaft side	Auxiliary input axis side			Connection shaft side	Auxiliary input axis side			Connection shaft side	Auxiliary input axis side	
Drive module	Virtual servo motor		16	16	—	—	32	32	—	—	8	8	—	—
	Synchronous encoder		8	8	—	—	12	12	—	—	8	8	—	—
Virtual axis	Virtual main shaft	—	16	16	—	—	32	32	—	—	8	8	—	—
	Virtual auxiliary input axis	—	16	16	—	—	32	32	—	—	8	8	—	—
Transmission module	Gear		32	32	1	1	64	64	1	1	16	16	1	1
	Direct clutch		32	32	1	1	64	64	1	1	16	16	1	1
	Smoothing clutch		32	32	1	1	64	64	1	1	16	16	1	1
	Speed change gear		32	32	1	1	64	64	1	1	16	16	1	1
	Differential gear		16	16	1	—	32	32	1	—	8	8	1	—
		16	1	—	—	32	1	—	—	8	1	—	—	
Output module	Roller		16	16	—	—	32	32	—	—	8	8	—	—
	Ball screw		16	16	—	—	32	32	—	—	8	8	—	—
	Rotary table		16	16	1	1	32	32	1	1	8	8	1	1
	Cam		16	16	—	—	32	32	—	—	8	8	—	—

APPENDIX 1.4 Differences of error codes

Table 1.5 Differences of error codes

Error code			Q170MCPU	QnUD(E)(H)CPU
PLC CPU area	Self-diagnosis error code	2124	<ul style="list-style-type: none"> A module is mounted on the settable slot or later slot. A module is mounted on the slot whose number is greater than the number of slots specified at [Slots] in [Standard setting] of the base setting. A module is mounted on the slot whose number of I/O points exceeds 512 points. A module is mounted on the slot whose number of I/O points strides 512 points. 	<ul style="list-style-type: none"> A module is mounted on the 65th slot or later slot. A module is mounted on the slot whose number is greater than the number of slots specified at [Slots] in [Standard setting] of the base setting. A module is mounted on the slot whose number of I/O points exceeds 4096 points. A module is mounted on the slot whose number of I/O points strides 4096 points.

Error code			Q170MCPU	Q173DCPU/Q172DCPU
Motion CPU area	Motion SFC parameter error	17004	Event task operation cycle setting error	—
	Servo program setting error	51	Rapid stop deceleration time setting error	—

The error details of Q170MCPU are shown below.

(1) Self-diagnosis error code (Error code: 2124)

Error code (SD0)	Error message	Common information (SD5 to SD15)	Individual information (SD16 to SD26)	LED display		CPU operation status	Diagnostic timing
				RUN	ERR.		
2124	SP. UNIT LAY ERR.	—	—	OFF	Flicker	Stop	At power ON/At reset

Error contents and cause	Corrective action
<ul style="list-style-type: none"> A module is mounted on the settable slot or later slot. A module is mounted on the slot whose number is greater than the number of slots specified at [Slots] in [Standard setting] of the base setting. A module is mounted on the slot whose number of I/O points exceeds 512 points. A module is mounted on the slot whose number of I/O points strides 512 points. 	<ul style="list-style-type: none"> Remove the module mounted on the settable slot or later slot. Remove the module mounted on the slot whose number is greater than the number of slots specified at [Slots] in [Standard setting] of the base setting. Remove the module mounted on the slot whose number of I/O points exceeds 512 points. Replace the module with the one whose number of occupied points does not exceed 512 points.

(2) Motion SFC parameter error (Error code: 17004)

Error code	Name	Description	Error processing	Corrective action
17004	Event task operation cycle setting error	The operation cycle setting value is outside the setting range.	The specified Motion SFC program does not start.	Turn PLC ready flag (M2000) OFF, set the operation cycle setting to 0.4[ms] or more, or default value.

(3) Servo program setting error (Error code: 51)

Error code	Name	Description	Error processing	Corrective action
51	Rapid stop deceleration time setting error	The rapid stop deceleration time is bigger than the setting value of deceleration time.	Control with the setting value of deceleration time.	Set the rapid stop deceleration time within the range of 1 to deceleration time.

APPENDIX 1.5 Differences of peripheral device interface

Table 1.6 Differences of peripheral device interface

Item		Q170MCPU	Q173DCPU/Q172DCPU
USB		Connect to the USB connector/ RS-232 connector of PLC CPU area.	Connect to the PLC CPU module.
RS-232			
PERIPHERAL I/F	Direct connection	Connect to the PERIPHERAL I/F connector of Motion CPU area.	—
	Connection via HUB		

The connection between Q170MCPU interface and programming software package/
GOT are shown below.

Peripheral device interface		Transfer	MT Developer2 (MR Configurator)	GX Developer	GOT (Direct bus connection to CPU)
USB			○	○	×
RS-232			○	○	○
PERIPHERAL I/F	Direct connection		○	×	×
	Connection via HUB		○	×	×

○: Possible ×: Impossible

The connection procedure for PERIPHERAL I/F is shown below.

(1) PERIPHERAL I/F

There are following two ways to communicate between the Motion controller and
MT Developer2.

- "Direct connection" connected with the Ethernet cable
- "Connection via HUB" connected via HUB

(a) Direct connection

Between the Motion controller and MT Developer2 can be connected using
one Ethernet cable without HUB.

The direct connection enables communication with only specifying
connection target. IP address setting is not required.

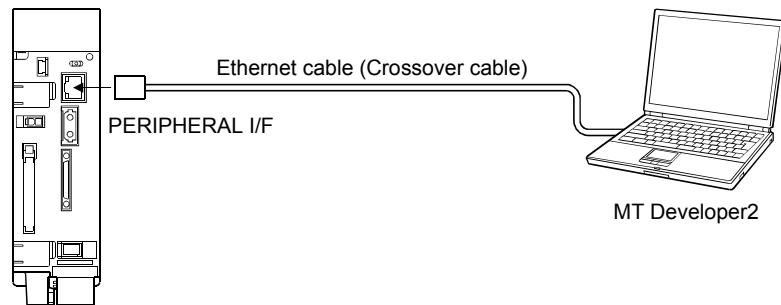

1) Communication setting in MT Developer2 side

Set the items on the Transfer Setup screen in MT Developer2 as shown below.

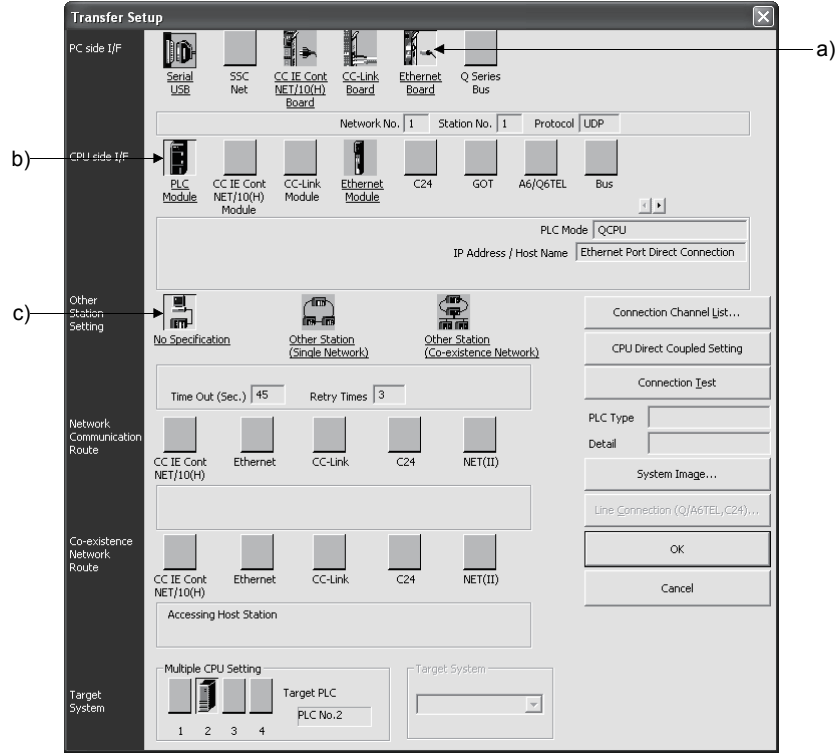

a) Select [Ethernet Board] for PC side I/F.

b) Select [PLC Module] for CPU side I/F.

Select the "Ethernet Port Direct Connection" on the CPU side I/F Detailed Setting of PLC Module screen.

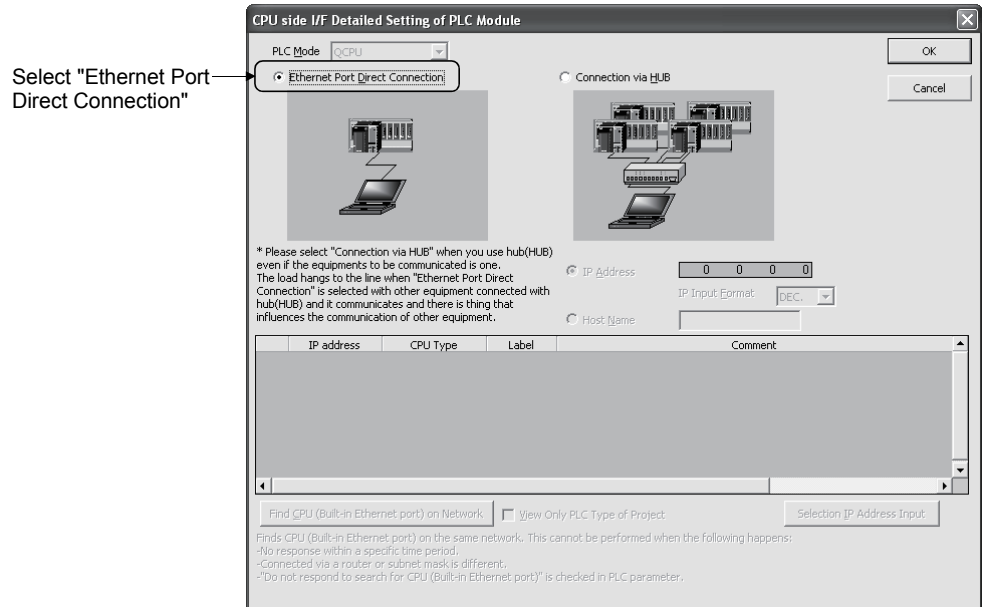

c) Make the setting for Other Station Setting.

2) Precautions

Precautions for direct connection between the Motion controller and MT Developer2 are shown below.

a) Connection to LAN line

When the Motion controller is connected to LAN line, do not perform communication using direct connection. If performed, the communication may put a load to LAN line and adversely affect communications of other devices.

b) Connection not connected directly

The system configuration that connects a Motion controller with an external device using a hub as shown below is not regarded as direct connection.

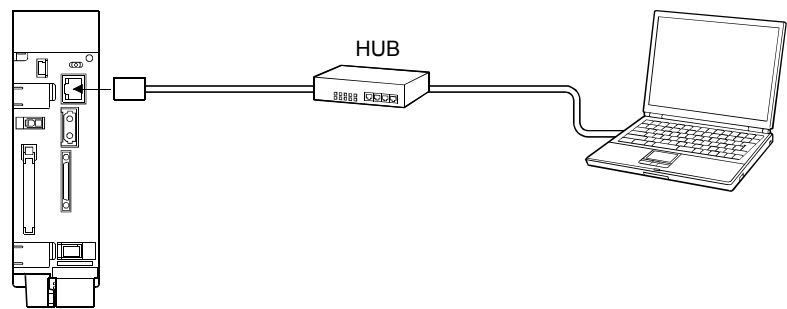

c) Condition in which direct connection communication may not be available

Under the following conditions, direct connection communication may not be available. In that case, check the setting of the Motion controller and/or personal computer.

- In the Motion controller IP address, bits corresponding to "0" in the personal computer subnet mask are all ON or all OFF.

(Example) Motion controller IP address : 64. 64. 255. 255
 Personal computer IP address : 64. 64. 1. 1
 Personal computer subnet mask : 255.255. 0. 0

- In the Motion controller IP address, bits corresponding to the host address for each class in the personal computer IP address are all ON or all OFF.

(Example) Motion controller IP address : 64. 64. 255. 255
 Personal computer IP address : 192.168. 0. 1
 Personal computer subnet mask : 255. 0. 0. 0

(b) Connection via HUB

Between the Motion controller and MT Developer2 can be connected via HUB.

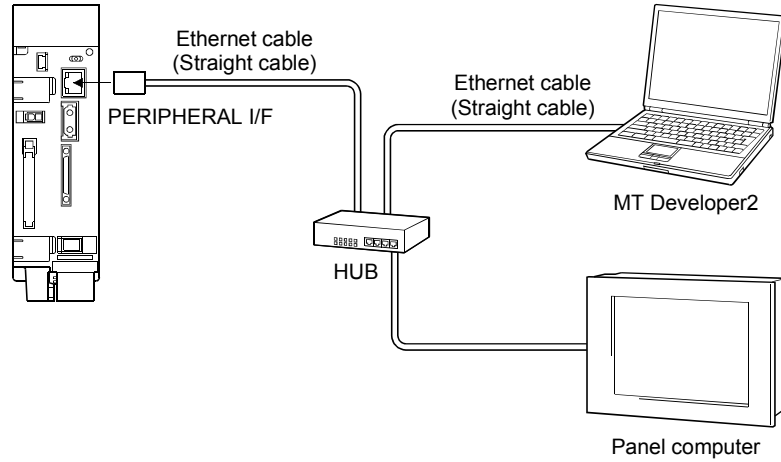

1) Setting in Motion controller side

Set the items on the Built-in Ethernet Port Setting in Basic Setting as shown below.

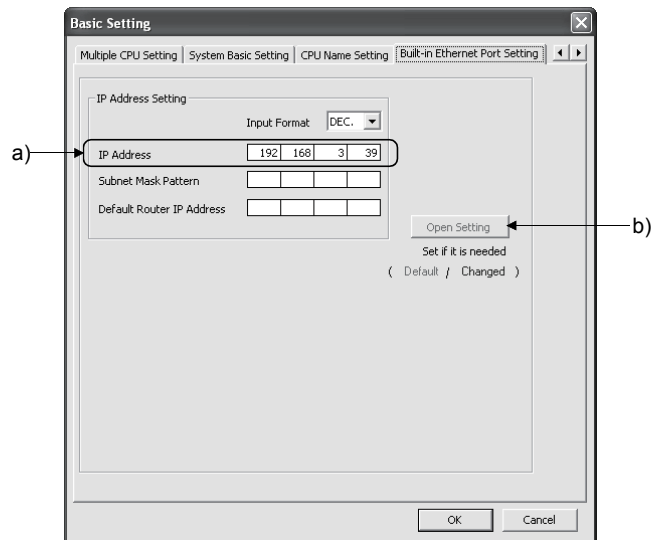

- a) Set the Motion controller IP address.
(Default IP address: 192.168.3.39)
Change the IP address if required.
No need to set "Subnet Mask Pattern" and "Default Router IP Address".

- b) Select the protocol ("TCP" or "UDP") to be used, in accordance with the external device on the Built-in Ethernet Port Open Setting screen.
 Select "TCP" to emphasize communication reliability.

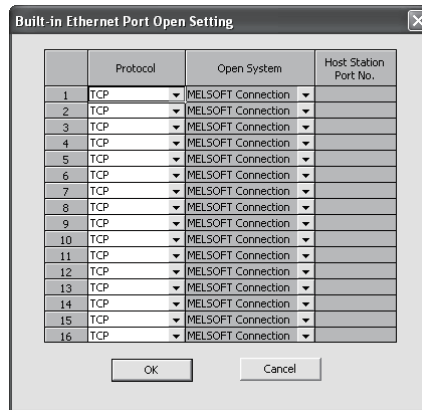

- Enabling the parameters of Motion controller
 Using Ethernet direct connection or USB/RS-232 connection, write the settings in parameter to the Motion controller by selecting [Online] - [Write to CPU] in MT Developer2. After writing the parameter settings, power the Motion controller OFF to ON or perform the reset operation of the Motion controller using the RUN/STOP/RESET switch so that the parameters become valid.

Connect directly with an Ethernet cable (crossover cable) between the personal computer and Motion controller to write the parameters using the Ethernet cable. Refer to this section (a) for details.

2) Communication setting in MT Developer2 side

Set the items on the Transfer Setup screen in MT Developer2 as shown below.

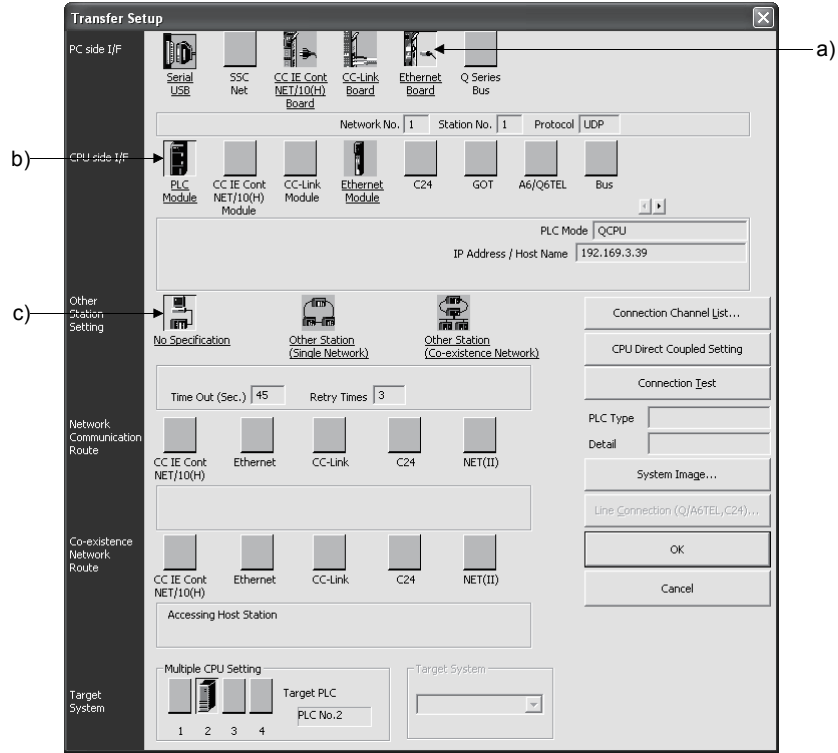

a) Select [Ethernet Board] for PC side I/F.

b) Select [PLC Module] for CPU side I/F.

Select the "Connection via HUB" on the CPU side I/F Detailed Setting of PLC Module screen, and set the Motion controller IP address.

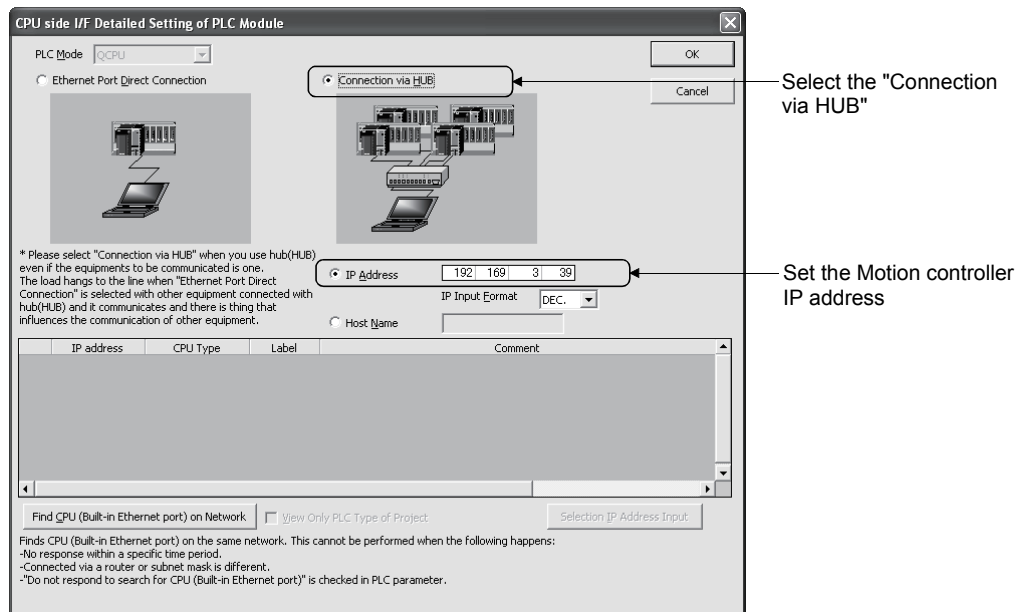

c) Make the setting for Other Station Setting.

POINT

The Find CPU function can be used for specifying the Motion controller IP address in the connection via HUB.

This function can be activated in [Find CPU (Built-in Ethernet port) on Network] of CPU side I/F Detailed Setting of PLC Module screen, finds the Motion controller connected to the same HUB as MT Developer2, and displays a list.

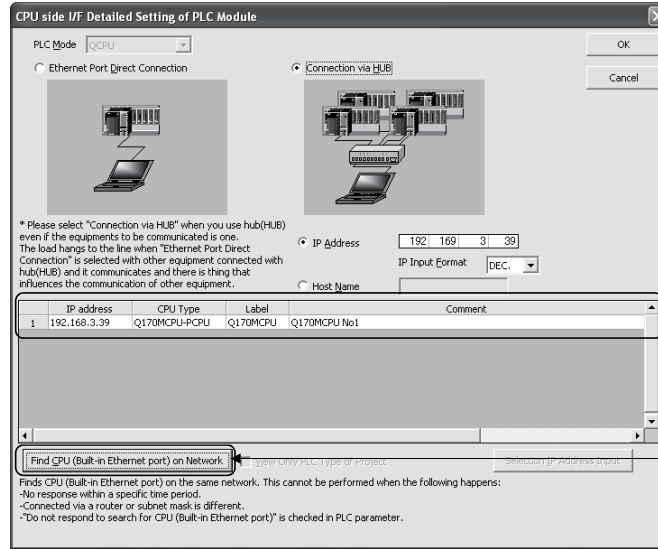

Found Motion controller is displayed.

[Find CPU (Built-in Ethernet port) on Network] button

- Set the label and comment of the Motion controller in [CPU Name Setting] of Basic Setting.

The label and comment set in [CPU Name Setting] are displayed on the CPU side I/F Detailed Setting of PLC Module screen.

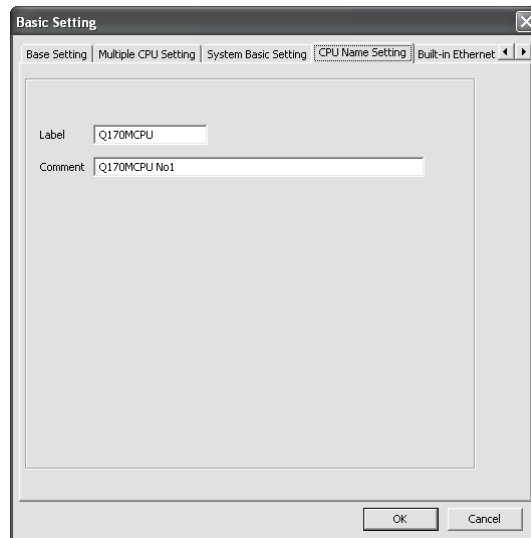

Item	Description	Setting range
Label	Enter a label (name and/or purpose) of the Motion controller.	Up to 10 characters
Comment	Enter comments regarding the Motion controller.	Up to 64 characters

3) Precautions

Precautions for connection between the Motion controller and MT Developer2 via HUB are shown below.

- a) When the personal computer that can connect to LAN line is used, set the same value for Motion controller IP address as the following personal computer IP address.

Motion controller IP address 192 168 3 39

Set the same value as the personal computer IP address

(Example) Personal computer IP address: "192.168.3.1"

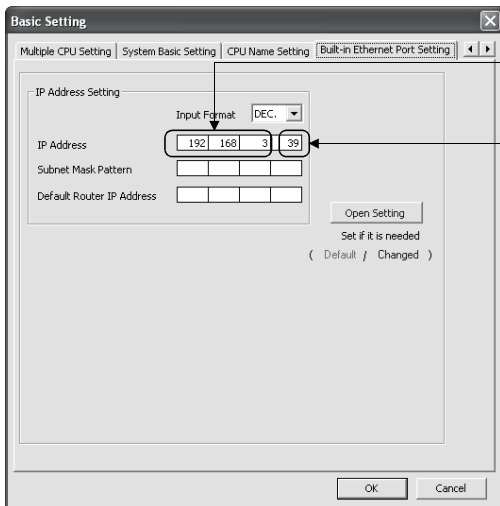
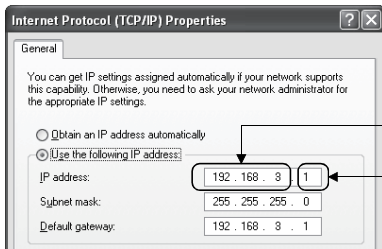

<Setting for Motion controller side>

Set the same value as the personal computer IP address. (Example) 192.168.3.□

Set the IP address not used with devices connected to network. (Example) □.□.□.39

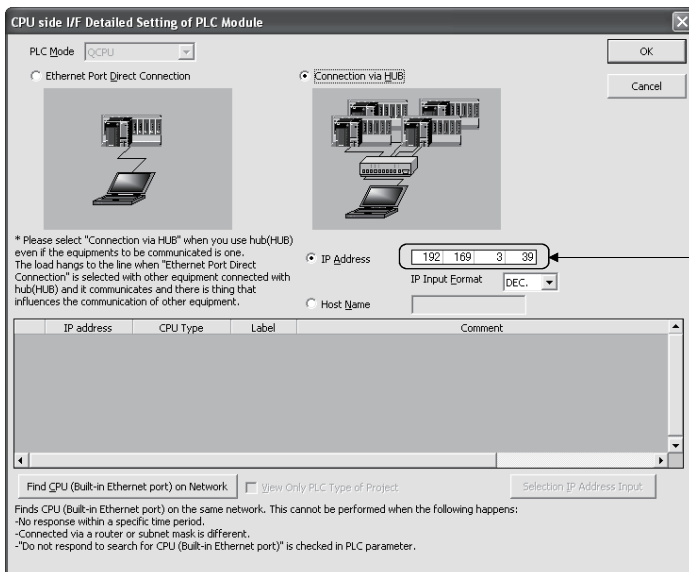

<Setting for MT Developer2 side>

Set the same value as the Motion controller IP address. (Example) 192.168.3.39

- b) The maximum number of devices that can access to one Motion controller simultaneously is 16.
- c) Hubs with 10BASE-T or 100BASE-TX ports can be used.
(The ports must comply with the IEEE802.3 100BASE-TX or IEEE802.3 10BASE-T standards.)
- d) The Ethernet cables must to be installed away from power cabling/lines.
- e) The module operation is not guaranteed if any of the following connection is used. Check the module operation on the user side.
 - Connections using the Internet (general public line)
 - Connections using devices in which a firewall is installed
 - Connections using broadband routers
 - Connections using wireless LAN
- f) When multiple Motion controllers are connected to MT Developer2, beware of the below cautions:
 - IP addresses must be different for each Motion controller.
 - Different projects must be used for each Motion controllers on MT Developer2.

APPENDIX 1.6 Differences of CPU display and I/O assignment

Table 1.7 Differences of CPU display and I/O assignment

Item		Q170MCPU	Q173DCPU/Q172DCPU
CPU display		<ul style="list-style-type: none"> Motion CPU area : Q170MCPU-PCPU PLC CPU area : Q170MCPU-SCPU 	<ul style="list-style-type: none"> Motion CPU : Q173DCPU, Q172DCPU PLC CPU : Q06UDHCPU, etc.
I/O assignment setting	Base mode (Auto)	<ul style="list-style-type: none"> The main base of eight slots corresponding is built into the Q170MCPU. 16 points are set to each empty slot. First address of the extension base is "70". 	<ul style="list-style-type: none"> The main base and extension base are automatically determined. I/O or empty slot, etc. is automatic determined, and the points are assigned.
	Base mode (Detail)	<ul style="list-style-type: none"> I/O assignment points are individually assigned. When the first address of the extension base is set to address "0", the setting is as follows. Main base: 8 slots Number of points of each empty slot: 0 point 	<ul style="list-style-type: none"> I/O assignment points are individually assigned.

The CPU display and setting of I/O assignment are shown below.

(1) CPU display

Confirm the CPU display of the PLC CPU area and Motion CPU area on the System Monitor screen displayed on [Diagnostics] – [System monitor] of GX Developer.

PLC CPU area is displayed as "Q170MCPU-SCPU", and Motion CPU area is displayed as "Q170MCPU-PCPU".

PLC CPU area (Q170MCPU-SCPU) Motion CPU area (Q170MCPU-PCPU)

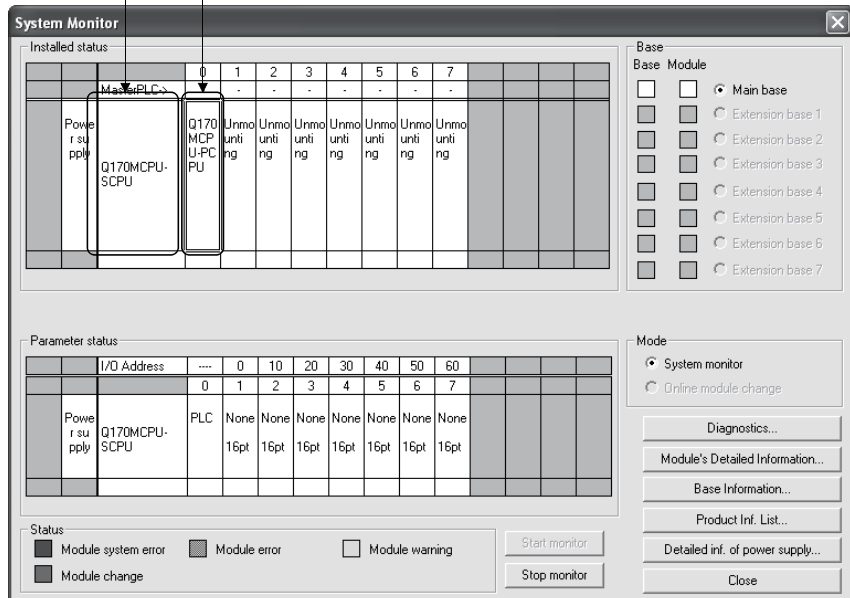

(2) Setting of I/O assignment

Set the I/O assignment points in [I/O assignment] of PC parameter of GX Developer.

(a) When the Base mode is set to "Auto" (default).

16 points are set to empty slot of the main base. Therefore, the first address of the extension base is set to "70".

(b) When the Base mode is set to "Detail".

The first address of the extension base is set to "0" by setting 0 point to the empty slot of the main base.

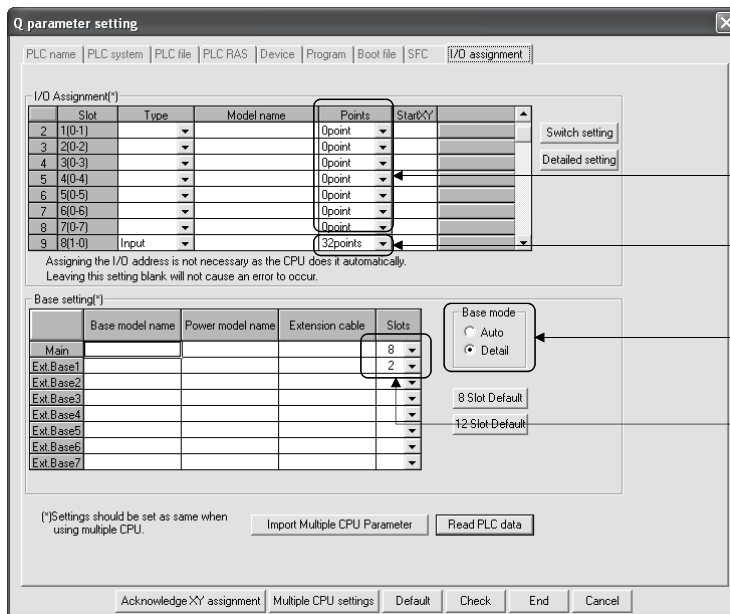

- Set the number of points of slot 1(0-1) to 7 (0-7) to "0 point".
- Set the number of points of I/O module.
- Set "Detail".
- Set the number of slots of the main base to "8".
Set the number of slots to be used to the number of slots of the extension base.

POINT

The first address of the extension base can be assigned from address "0" by using the sample data.

Refer to "APPENDIX 2" for details of the sample data.

APPENDIX 2 Creation of project

There are following methods to create the Q170MCPU project.

- (1) Create the new project.
- (2) Convert the project for Q17□DCPU/Q17□HCPU(-T)/Q17□CPUN(-T)/
Q17□CPU.
- (3) Create the new project using the sample data.

Refer to the help of MT Developer2 for creation method of project.

The contents to create the project using the sample data describes in APPENDIX 2.1.

APPENDIX 2.1 Sample data

An easy setting can be achieved for the parameter setting such as the automatic refresh setting of Multiple CPU setting and I/O assignment setting by using the sample data.

Creation of project using the sample data is suitable for the machine control in the sequence program.

The sample data have two types (Motion CPU area, PLC CPU area).

(1) Overview

(a) Multiple CPU setting

An easy setting can be achieved for the automatic refresh setting of positioning dedicated signal between the PLC CPU area and Motion CPU area.

(b) I/O assignment setting

The main base of eight slots or equivalent is built into the Q170M CPU. All points of "empty slot" not used on the main base are set to "0" point by the sample data.

(c) Device comment

The name of positioning dedicated signal can be used as the device comment of the sequence program.

(2) How to use

The following methods to use the sample data are shown below.

- Divert the sample data.
- Overwrite the sample data to the created project.

(3) Setting description

Outline of overwrite sample data is shown table below.

Add the extension base units and each module according to the system.

Refer to this section (7) for details of the sample data.

CPU area	Item	Description	Project name		Programming software package
			SV13	SV22	
Motion CPU area	Base setting	<ul style="list-style-type: none"> • Extension base Stage1, Stage 2 	Q170M_SV13_MT2	Q170M_SV22_MT2	MT Developer2
	Multiple CPU setting	<ul style="list-style-type: none"> • Multiple CPU high speed transmission area setting • Automatic refresh setting of CPU No.1, 2 			
PLC CPU area	I/O assignment	<ul style="list-style-type: none"> • Base setting No. of slots for the base unit used • I/O assignment Unit types, I/O points, I/O number • Base mode setting 	Q170M_SV13_GX1	Q170M_SV22_GX1	GX Developer
	PLC system	Points occupied by empty slot			
	Multiple CPU settings	<ul style="list-style-type: none"> • No. of PLC • Multiple CPU high speed transmission area setting • Auto refresh setting of CPU No.1, 2 			
	Device comment	Set the name of positioning dedicated signal to the comment of device.			

(4) Precautions

- (a) By using the sample data, the positioning dedicated signals of the Motion CPU area are changed to the device value of PLC CPU area by the automatic refresh. It needs to set again the automatic refresh setting after rewriting the sample data to transmit the data to the positioning dedicated signal using the Motion SFC program.
- (b) The existing data are overwrite and erased by diverting the sample data to the created project.

(5) Procedure for project creation

- (a) When the sample data is diverted.

1) Motion CPU area

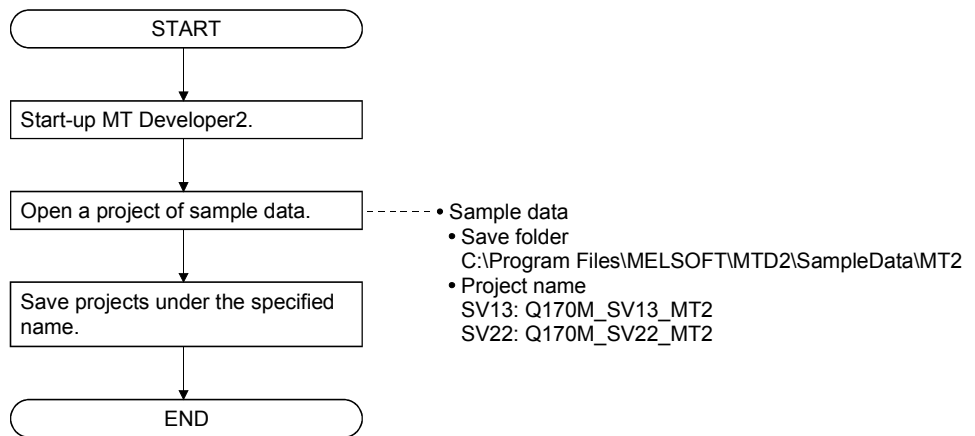

2) PLC CPU area

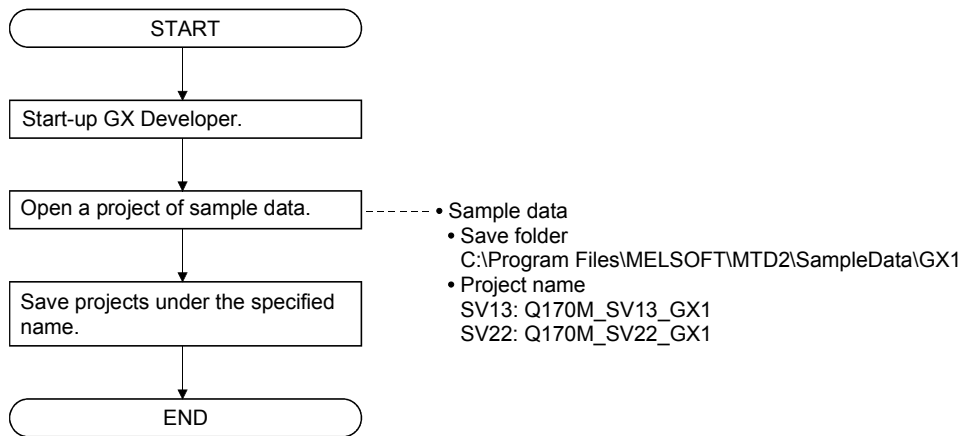

(b) When the sample data is overwrite to the created project.

1) Motion CPU area

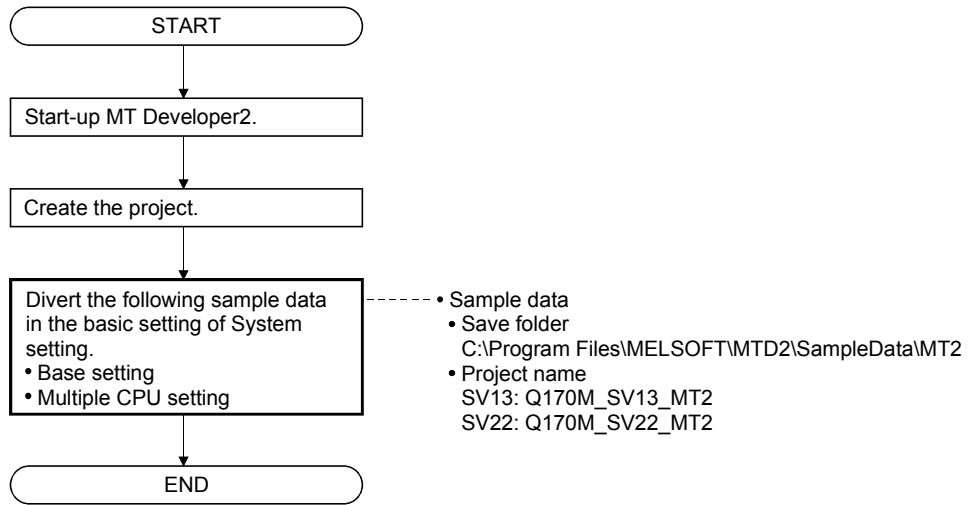

2) PLC CPU area

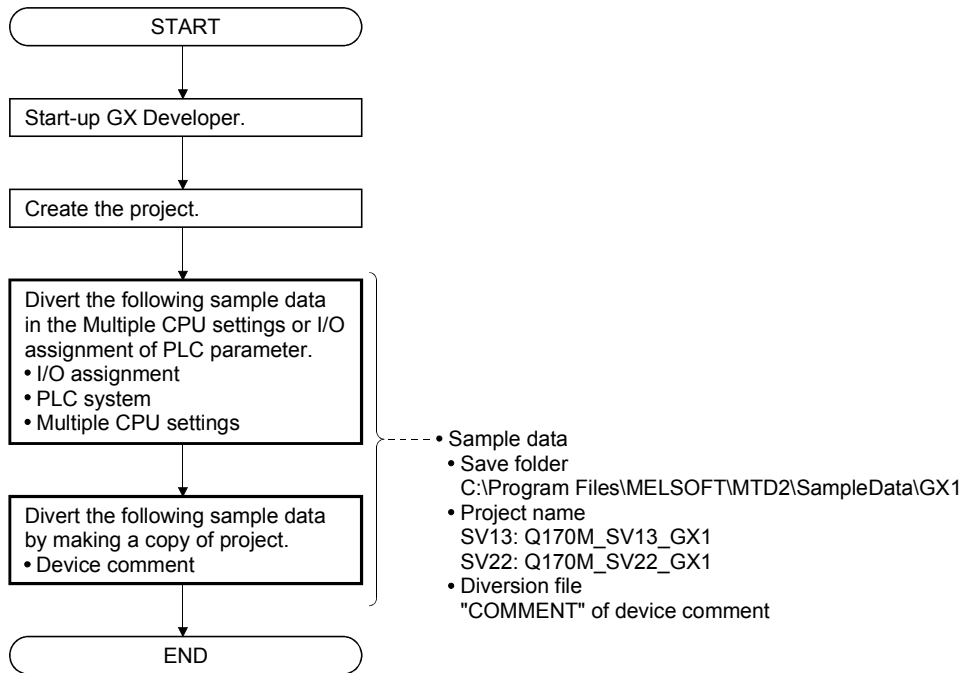

POINT

The existing data are overwrite and erased by diverting the sample data to the created project.

(6) Operation procedure for sample data
Refer to the help of MT Developer2 for details.

- (a) Motion CPU area (MT Developer2)
 - 1) Multiple CPU setting

a) Diversion of sample data

Divert the sample data by selecting the [Import Multiple CPU Parameter] button of the base setting or Multiple CPU setting of the basic setting of system setting.

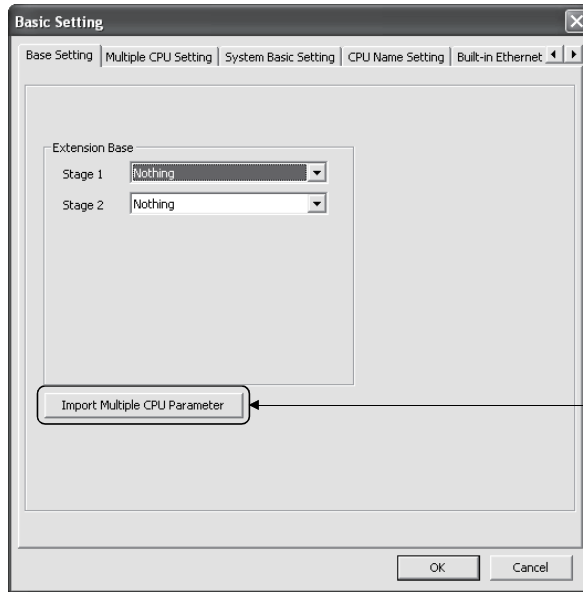

Select the [Import Multiple CPU Parameter] button

b) Confirm the sample data

Compare the Automatic Refresh Setting List screen with the contents of this section (7), and then confirm the sample data are diverted correctly.

CPU	Points(k)	CPU specific send range(*)			Automatic Refresh
		Points	Start	End	
No.1	7	7022	G10000	G17021	146
No.2	7	6482	G10000	G16481	686

Setting No.	Automatic Refresh					
	No.1			No.2		
	Points	Start	End	Points	Start	End
1	28	M3072	M3519	46	M2000	M2735
2	118	D640	D757	320	D0	D319
3				320	#8000	#8319
4						
5						
6						
7						
8						
9						
10						
11						
12						
13						
14						
15						
16						

Data of automatic refresh

(b) PLC CPU area (GX Developer)

1) Multiple CPU settings / I/O assignment

a) Diversion of sample data

Divert the sample data by selecting the [Import Multiple CPU Parameter] button of the Multiple CPU settings or I/O assignment of the PLC parameter setting.

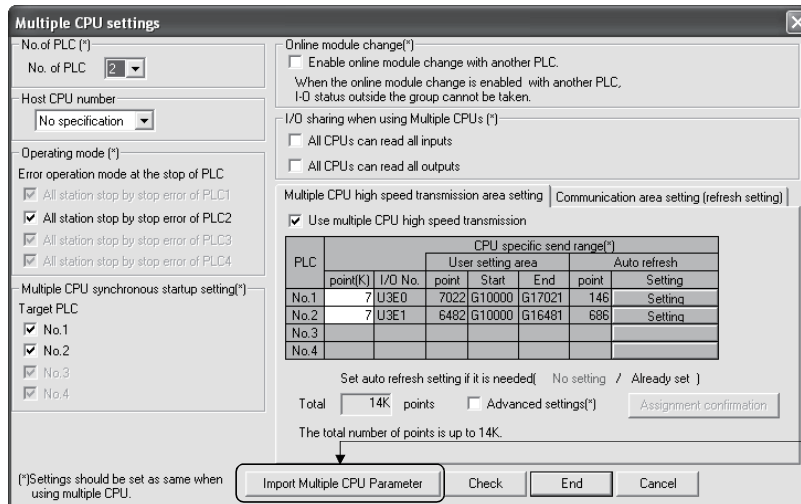

Select the [Import Multiple CPU Parameter] button

- b) Confirm the sample data
Compare the Auto refresh settings screen with the contents of this section (7), and then confirm the sample data are diverted correctly.

• Multiple CPU settings

Auto refresh settings

PLC No.1 | PLC No.2

Refresh device --- Shared memory(PLC No.2)

No.	point(*)	Auto refresh		CPU specific send range (U3E1V)	
		Start	End	Start	End
1	46	M2000	M2735	...	G16482 G16527
2	320	D0	D319	...	G16528 G16847
3	320	D8000	D8319	...	G16848 G17167
4					
5					
6					
7					
8					
9					
10					
11					
12					
13					
14					
15					
16					

Total points: 686 Settable points: 7168

Available start devices are X,Y,M,L,B,D, W,R,ZR,SM,SD,SB,SW.

Word is used for points. Every 2 points are counted as a set.

(*Settings should be set as same when using multiple CPU.)

Check End Cancel

• I/O assignment

Q parameter setting

PLC name | PLC system | PLC file | PLC RAS | Device | Program | Boot file | SFC | I/O assignment

I/O Assignment(*)

Slot	PLC	Type	Model name	Points	StartXY
1	PLC	PLC No.2		3E10	
2	1(0-1)	Empty		Opoint 0000	
3	2(0-2)	Empty		Opoint 0000	
4	3(0-3)	Empty		Opoint 6666	
5	4(0-4)	Empty		Opoint 0000	
6	5(0-5)	Empty		Opoint 0000	
7	6(0-6)	Empty		Opoint 0000	
8	7(0-7)	Empty		Opoint 0000	

Assigning the I/O address is not necessary as the CPU does it automatically.
Leaving this setting blank will not cause an error to occur.

Base setting(*)

Base model name	Power model name	Extension cable	Slots
Main			8
Ext.Base1			
Ext.Base2			
Ext.Base3			
Ext.Base4			
Ext.Base5			
Ext.Base6			
Ext.Base7			

Base mode: Auto (selected), Detail

8 Slot Default, 12 Slot Default

(*Settings should be set as same when using multiple CPU.)

Import Multiple CPU Parameter Read PLC data

Acknowledge XY assignment Multiple CPU settings Default Check End Cancel

2) Device comment

The device comment data is allocated in the Multiple CPU high speed transmission area setting for the positioning dedicated signal.

The device can be used while confirming the comment to execute the control for the Motion CPU area in the PLC CPU area.

- a) Select the device comment "COMMENT" on the copy screen displayed by [Project] – [Copy] of menu bar of device comment.

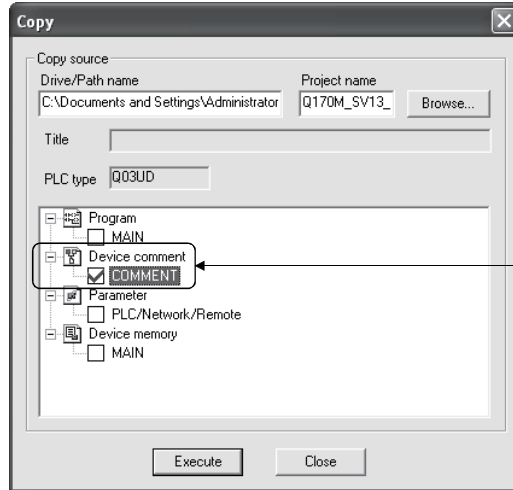

Select the "COMMENT"

(7) Description of sample data

(a) Motion CPU area

1) SV13 (Q170M_SV13_MT2)

a) Base setting

Setting items		Description
Extension base	Stage 1	Nothing
	Stage 2	Nothing

b) Multiple CPU setting

Setting items		Description
Operating mode		All station stop by stop error of CPU 1/2
Multiple CPU synchronous startup setting		Set CPU No. 1/2 to synchronous startup

c) Multiple CPU high speed transmission area setting

CPU	CPU specific send range				
	Points (k)	User setting area			Automatic refresh
		Points	Start	End	Points
No.1	7	7022	G10000	G17021	146
No.2	7	6482	G10000	G16481	686

d) Automatic refresh setting

• CPU No.1 (Receive)

Setting No.	Automatic refresh				CPU specific send range(U3E0\)	
	Points	Start	End		Start	End
1	28	M3072	M3519	←	G17022	G17049
2	118	D640	D757	←	G17050	G17167

• CPU No.2 (Send)

Setting No.	Automatic refresh				CPU specific send range(U3E1\)	
	Points	Start	End		Start	End
1	46	M2000	M2735	→	G16482	G16527
2	320	D0	D319	→	G16528	G16847
3	320	#8000	#8319	→	G16848	G17167

2) SV22 (Q170M_SV22_MT2)

a) Base setting

Setting items		Description
Extension base	Stage 1	Nothing
	Stage 2	Nothing

b) Multiple CPU setting

Setting items		Description
Operating mode		All station stop by stop error of CPU 1/2
Multiple CPU synchronous startup setting		Set CPU No. 1/2 to synchronous startup

c) Multiple CPU high speed transmission area setting

CPU	CPU specific send range				
	Points (k)	User setting area			Automatic refresh
		Points	Start	End	Points
No.1	7	6980	G10000	G16979	188
No.2	7	5840	G10000	G15839	1328

d) Automatic refresh setting

• CPU No.1 (Receive)

Setting No.	Automatic refresh				CPU specific send range(U3E0\)	
	Points	Start	End		Start	End
1	28	M3072	M3519	←	G16980	G17007
2	42	M4800	M5471	←	G17008	G17049
3	118	D640	D757	←	G17050	G17167

• CPU No.2 (Send)

Setting No.	Automatic refresh				CPU specific send range(U3E1\)	
	Points	Start	End		Start	End
1	46	M2000	M2735	→	G15840	G15885
2	42	M4000	M4671	→	G15886	G15927
3	320	D0	D319	→	G15928	G16247
4	600	D800	D1399	→	G16248	G16847
5	320	#8000	#8319	→	G16848	G17167

APPENDICES

- (b) PLC CPU area
 - 1) SV13 (Q170M_SV13_GX1)
 - a) I/O assignment
 - I/O assignment

Setting items		Description							
Slot	PLC	PLC	1	2	3	4	5	6	7
Type	PLC No.1	PLC No.2	Empty	Empty	Empty	Empty	Empty	Empty	Empty
Points			0 point	0 point	0 point	0 point	0 point	0 point	0 point
Start XY	3E00	3E10	0000	0000	0000	0000	0000	0000	0000
Switch setting	Switch 1		—	—	—	—	—	—	—
	Switch 2		—	—	—	—	—	—	—
	Switch 3		—	—	—	—	—	—	—
	Switch 4		—	—	—	—	—	—	—
	Switch 5		—	—	—	—	—	—	—
Detailed setting	Error time output mode	—	—	—	—	—	—	—	—
	Hardware error time PLC operation mode	—	—	—	—	—	—	—	—
	I/O response time	—	—	—	—	—	—	—	—
	Control PLC	—	—	PLC No.1	PLC No.1	PLC No.1	PLC No.1	PLC No.1	PLC No.1

• Base setting

Setting items	Description
Slots (Main)	8
Base mode	Detail

b) Multiple CPU settings

Setting items		Description				
1	No. of PLC	2 modules				
2	Host CPU number	No specification				
3	Operating mode	All station stop by stop error of PLC1/PLC2				
4	Multiple CPU synchronous startup setting	Check the PLC No.1/PLC No.2				
5	Online module change	Not check the Enable online module change with another PLC				
6	Input sharing when using Multiple CPUs	Not check the all CPUs can read all inputs				
7	Output sharing when using Multiple CPUs	Not check the all CPUs can read all outputs				
8	Multiple CPU high speed transmission area setting	Use multiple CPU high speed communication				
		PLC	CPU specific send range			
			User setting area			Auto refresh
		point (k)	I/O No.	point	Start	End
No.1	7	U3E0	7022	G10000	G17021	146
No.2	7	U3E1	6482	G10000	G16481	686

APPENDICES

c) Auto refresh settings

• PLC No.1

No.	Auto refresh				CPU specific send range(U3E0)	
	Point	Start	End		Start	End
1	28	M3072	M3519	—	G17022	G17049
2	118	D640	D757	—	G17050	G17167

• PLC No.2

No.	Auto refresh				CPU specific send range(U3E1)	
	Point	Start	End		Start	End
1	46	M2000	M2735	—	G16482	G16527
2	320	D0	D319	—	G16528	G16847
3	320	D8000	D8319	—	G16848	G17167

d) PLC system setting

Only "Points occupied by empty slot" is overwrite at the sample data diversion. The content before sample data diversion are retained without rewriting for the other data.

Setting items			Description
1	Timer limit setting	Low speed	100ms
		High speed	10.00ms
2	RUN-PAUSE contacts	RUN	Not used
		PAUSE	Not used
3	Latch data backup operation valid contact		Not used
4	Remote reset		Not checked
5	Output mode at STOP to RUN		Check the Previous state
6	Floating point arithmetic processing		—
7	Intelligent function module setting		Not used
8	Module synchronization		Check the Synchronize intelligent module's pulse up
9	Common pointer No.		Not used
10	Points occupied by empty slot		16 points
11	System interrupt settings	Interrupt counter start No.	—
		I28 Fixed scan interval	100.0ms
		I29 Fixed scan interval	40.0ms
		I30 Fixed scan interval	20.0ms
		I31 Fixed scan interval	10.0ms
12	Interrupt program / Fixed scan program setting		Not check the High speed execution
13	A-PLC		Not checked
14	Service processing setting	Scan time rate	10%
15	CPU module change setting		Not used

APPENDICES

2) SV22 (Q170M_SV22_GX1)

a) I/O assignment

- I/O assignment

Setting items		Description								
Slot		PLC	PLC	1	2	3	4	5	6	7
Type		PLC No.1	PLC No.2	Empty	Empty	Empty	Empty	Empty	Empty	Empty
Points				0 point	0 point	0 point	0 point	0 point	0 point	0 point
Start XY		3E00	3E10	0000	0000	0000	0000	0000	0000	0000
Switch setting	Switch 1			—	—	—	—	—	—	—
	Switch 2			—	—	—	—	—	—	—
	Switch 3			—	—	—	—	—	—	—
	Switch 4			—	—	—	—	—	—	—
	Switch 5			—	—	—	—	—	—	—
Detailed setting	Error time output mode	—	—	—	—	—	—	—	—	—
	Hardware error time PLC operation mode	—	—	—	—	—	—	—	—	—
	I/O response time	—	—	—	—	—	—	—	—	—
	Control PLC	—	—	PLC No.1	PLC No.1	PLC No.1	PLC No.1	PLC No.1	PLC No.1	PLC No.1

- Base setting

Setting items	Description
Slots (Main)	8
Base mode	Detail

b) Multiple CPU setting

	Setting items	Description																														
1	No. of PLC	2 modules																														
2	Host CPU number	No specification																														
3	Operating mode	All station stop by stop error of PLC1/PLC2																														
4	Multiple CPU synchronous startup setting	Check the PLC No.1/PLC No.2																														
5	Online module change	Not check the Enable online module change with another PLC																														
6	Input sharing when using Multiple CPUs	Not check the all CPUs can read all inputs																														
7	Output sharing when using Multiple CPUs	Not check the all CPUs can read all outputs																														
8	Multiple CPU high speed transmission area setting	Use multiple CPU high speed communication <table border="1" style="margin-left: 20px;"> <thead> <tr> <th rowspan="2">PLC</th> <th colspan="6">CPU specific send range</th> </tr> <tr> <th rowspan="2">point (k)</th> <th rowspan="2">I/O No.</th> <th colspan="3">User setting area</th> <th rowspan="2">Auto refresh point</th> </tr> <tr> <th>point</th> <th>Start</th> <th>End</th> </tr> </thead> <tbody> <tr> <td>No.1</td> <td>7</td> <td>U3E0</td> <td>6980</td> <td>G10000</td> <td>G16979</td> <td>188</td> </tr> <tr> <td>No.2</td> <td>7</td> <td>U3E1</td> <td>5840</td> <td>G10000</td> <td>G15839</td> <td>1328</td> </tr> </tbody> </table>	PLC	CPU specific send range						point (k)	I/O No.	User setting area			Auto refresh point	point	Start	End	No.1	7	U3E0	6980	G10000	G16979	188	No.2	7	U3E1	5840	G10000	G15839	1328
PLC	CPU specific send range																															
	point (k)	I/O No.	User setting area			Auto refresh point																										
point			Start	End																												
No.1	7	U3E0	6980	G10000	G16979	188																										
No.2	7	U3E1	5840	G10000	G15839	1328																										

APPENDICES

c) Auto refresh settings

• PLC No.1

No.	Auto refresh				CPU specific send range(U3E0)	
	Point	Start	End		Start	End
1	28	M3072	M3519	—	G16980	G17007
2	42	M4800	M5471	—	G17008	G17049
3	118	D640	D757	—	G17050	G17167

• PLC No.2

No.	Auto refresh				CPU specific send range(U3E1)	
	Point	Start	End		Start	End
1	46	M2000	M2735	—	G15840	G15885
2	42	M4000	M4671	—	G15886	G15927
3	320	D0	D319	—	G15928	G16247
4	600	D800	D1399	—	G16248	G16847
5	320	D8000	D8319	—	G16848	G17167

d) PLC system

Only "Points occupied by empty slot" is overwrite at the sample data diversion. The content before sample data diversion are retained without rewriting for the other data.

Setting items			Description
1	Timer limit setting	Low speed	100ms
		High speed	10.00ms
2	RUN-PAUSE contacts	RUN	Not used
		PAUSE	Not used
3	Latch data backup operation valid contact		Not used
4	Remote reset		Not checked
5	Output mode at STOP to RUN		Check the Previous state
6	Floating point arithmetic processing		—
7	Intelligent function module setting		Not used
8	Module synchronization		Check the Synchronize intelligent module's pulse up
9	Common pointer No.		Not used
10	Points occupied by empty slot		16 points
11	System interrupt settings	Interrupt counter start No.	—
		I28 Fixed scan interval	100.0ms
		I29 Fixed scan interval	40.0ms
		I30 Fixed scan interval	20.0ms
		I31 Fixed scan interval	10.0ms
12	Interrupt program / Fixed scan program setting		Not check the High speed execution
13	A-PLC		Not checked
14	Service processing setting	Scan time rate	10%
15	CPU module change setting		Not used

(8) Automatic refresh of sample data

The data to the internal relay and data register of PLC CPU area are transmitted to the positioning dedicated signals of Motion CPU area via the Multiple CPU high speed transmission area.

The positioning dedicated signals of Motion CPU area can be controlled by only control of the sequence program of PLC CPU area.

And, add the special relays, special registers and user devices to the parameters of automatic refresh if required.

The flow for the data of automatic refresh that uses the sample data is shown below.

(Example) SV13 use

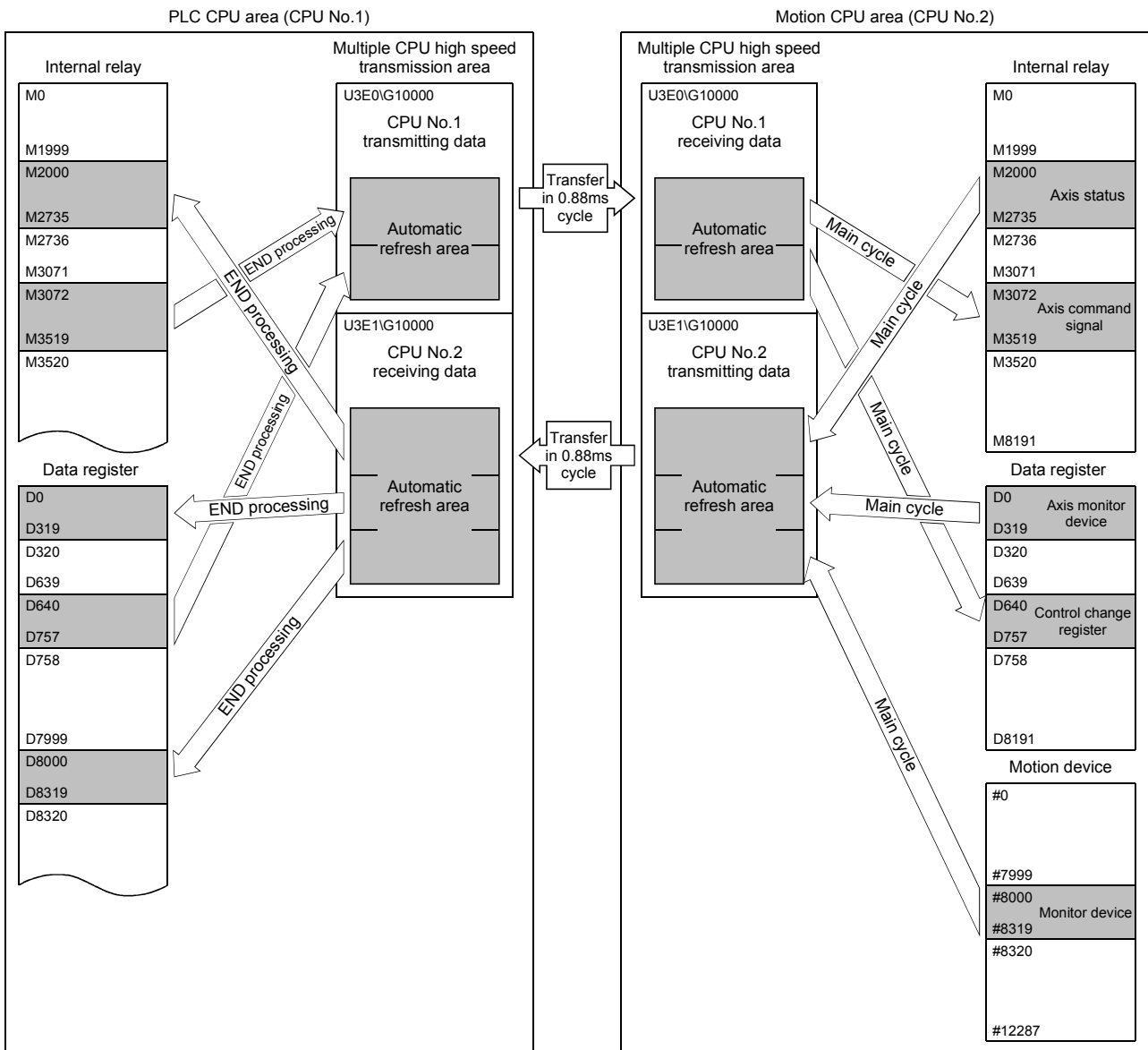

APPENDIX 3 Processing Times

APPENDIX 3.1 Processing time of operation control/Transition instruction

(1) Operation instructions

Processing time of operation instructions

Classifications	Symbol	Instruction	Operation expression	Processing time [μs] Q170MCPU
Binary operation	=	Substitution	#0=#1	1.5
			D800=D801	
			U3E1\G10000=U3E1\G10001	2.0
			#0L=#2L	1.5
			D800L=D802L	
			U3E1\G10000L=U3E1\G10002L	2.0
			#0F=#4F	
			D800F=D804F	
	U3E1\G10000F=U3E1\G10004F	3.0		
	+	Addition	#0=#1+#2	2.0
			D800=D801+D802	
			U3E1\G10000=U3E1\G10001+U3E1\G10002	3.0
			#0L=#2L+#4L	2.5
			D800L=D802L+D804L	
			U3E1\G10000L=U3E1\G10002L+U3E1\G10004L	3.5
			#0F=#4F+#8F	3.0
			D800F=D804F+D808F	
	U3E1\G10000F=U3E1\G10004F+U3E1\G10008F	4.5		
	-	Subtraction	#0=#1-#2	2.5
			D800=D801-D802	
			U3E1\G10000=U3E1\G10001-U3E1\G10002	3.5
			#0L=#2L-#4L	2.5
			D800L=D802L-D804L	
			U3E1\G10000L=U3E1\G10002L-U3E1\G10004L	3.5
			#0F=#4F-#8F	3.0
			D800F=D804F-D808F	
	U3E1\G10000F=U3E1\G10004F-U3E1\G10008F	5.0		
	*	Multiplication	#0=#1*#2	2.5
D800=D801*D802				
U3E1\G10000=U3E1\G10001*U3E1\G10002			4.0	
#0L=#2L*#4L			2.5	
D800L=D802L*D804L				
U3E1\G10000L=U3E1\G10002L*U3E1\G10004L			4.0	
#0F=#4F*#8F			3.5	
D800F=D804F*D808F				
U3E1\G10000F=U3E1\G10004F*U3E1\G10008F	5.0			
/	Division	#0=#1/#2	2.5	
		D800=D801/D802		
		U3E1\G10000=U3E1\G10001/U3E1\G10002	3.5	

Processing time of operation instructions (continued)

Classifications	Symbol	Instruction	Operation expression	Processing time [μs] Q170MCPU
Binary operation	/	Division	#0L=#2L/#4L	2.5
			D800L=D802L/D804L	
			U3E1\G10000L=U3E1\G10002L/U3E1\G10004L	3.5
			#0F=#4F/#8F	
			D800F=D804F/D808F	
	U3E1\G10000F=U3E1\G10004F/U3E1\G10008F	4.5		
	%	Remainder	#0=#1%#2	2.5
			D800=D801%D802	3.0
			U3E1\G10000=U3E1\G10001%U3E1\G10002	
			#0L=#2L%#4L	
D800L=D802L%D804L			2.5	
U3E1\G10000L=U3E1\G10002L%U3E1\G10004L	3.5			
Bit operation	~	Bit inversion (complement)	#0=~#1	1.5
			D800=~D801	
			U3E1\G10000=~U3E1\G10001	2.0
			#0L=~#2L	1.5
			D800L=~D802L	
	U3E1\G10000L=~U3E1\G10002L	2.5		
	&	Bit logical AND	#0=#1	2.5
			D800=D801&D802	
			U3E1\G10000=U3E1\G10001&U3E1\G10002	3.5
			#0L=#2LL	2.0
			D800L=D802L&D804L	
	U3E1\G10000L=U3E1\G10002L&U3E1\G10004L	3.5		
		Bit logical OR	#0=#1 #2	2.0
			D800=D801 D802	
			U3E1\G10000=U3E1\G10001 U3E1\G10002	3.0
			#0L=#2L #4L	2.0
			D800L=D802L D804L	
	U3E1\G10000L=U3E1\G10002L U3E1\G10004L	3.0		
	^	Bit exclusive OR	#0=#1^#2	2.0
			D800=D801^D802	
U3E1\G10000=U3E1\G10001^U3E1\G10002			3.0	
#0L=#2L^#4L			2.0	
D800L=D802L^D804L				
U3E1\G10000L=U3E1\G10002L^U3E1\G10004L	3.0			
>>	Bit right shift	#0=#1>>#2	2.5	
		D800=D801>>D802		
		U3E1\G10000=U3E1\G10001>>U3E1\G10002	3.5	
		#0L=#2L>>#4L	2.5	
		D800L=D802L>>D804L		
U3E1\G10000L=U3E1\G10002L>>U3E1\G10004L	3.0			
<<	Bit left shift	#0=#1<<#2	2.0	
		D800=D801<<D802		
		U3E1\G10000=U3E1\G10001<<U3E1\G10002	3.5	
		#0L=#2L<<#4L	2.0	
		D800L=D802L<<D804L		
U3E1\G10000L=U3E1\G10002L<<U3E1\G10004L	3.0			

Processing time of operation instructions (continued)

Classifications	Symbol	Instruction	Operation expression	Processing time [μs] Q170MCPU
Sign	-	Sign inversion (complement of 2)	#0=#1	1.5
			D800=-D812	
			U3E1\G10000=-U3E1\G10001	2.5
			#0L=#2L	2.0
			D800L=-D802L	
			U3E1\G10000L=-U3E1\G10002L	2.5
			#0F=#4F	2.0
D800F=-D804F				
U3E1\G10000F=-U3E1\G10004F	3.0			
Standard function	SIN	Sine	#0F=SIN(#4F)	4.5
			D800F=SIN(D804F)	
			U3E1\G10000F=SIN(U3E1\G10004F)	5.5
	COS	Cosine	#0F=COS(#4F)	4.5
			D800F=COS(D804F)	
			U3E1\G10000F=COS(U3E1\G10004F)	5.5
	TAN	Tangent	#0F=TAN(#4F)	6.0
			D800F=TAN(D804F)	
			U3E1\G10000F=TAN(U3E1\G10004F)	7.0
	ASIN	Arcsine	#0F=ASIN(#4F)	12.5
			D800F=ASIN(D804F)	
			U3E1\G10000F=ASIN(U3E1\G10004F)	14.5
	ACOS	Arccosine	#0F=ACOS(#4F)	10.5
			D800F=ACOS(D804F)	
			U3E1\G10000F=ACOS(U3E1\G10004F)	11.5
	ATAN	Arctangent	#0F=ATAN(#4F)	4.5
			D800F=ATAN(D804F)	
			U3E1\G10000F=ATAN(U3E1\G10004F)	6.0
	SQRT	Square root	#0F=SQRT(#4F)	2.5
			D800F=SQRT(D804F)	
			U3E1\G10000F=SQRT(U3E1\G10004F)	3.5
	LN	Natural logarithm	#0F=LN(#4F)	5.5
			D800F=LN(D804F)	
			U3E1\G10000F=LN(U3E1\G10004F)	
	EXP	Exponential operation	#0F=EXP(#4F)	4.0
			D800F=EXP(D804F)	
			U3E1\G10000F=EXP(U3E1\G10004F)	4.5
ABS	Absolute value	#0F=ABS(#4F)	2.0	
		D800F=ABS(D804F)		
		U3E1\G10000F=ABS(U3E1\G10004F)	3.0	
RND	Round-off	#0F=RND(#4F)	2.5	
		D800F=RND(D804F)		
		U3E1\G10000F=RND(U3E1\G10004F)	3.5	
FIX	Round-down	#0F=FIX(#4F)	2.5	
		D800F=FIX(D804F)		
		U3E1\G10000F=FIX(U3E1\G10004F)	3.5	
FUP	Round-up	#0F=FUP(#4F)	2.5	
		D800F=FUP(D804F)		
		U3E1\G10000F=FUP(U3E1\G10004F)	3.5	

Processing time of operation instructions (continued)

Classifications	Symbol	Instruction	Operation expression	Processing time [μs] Q170MCPU
Standard function	BIN	BCD→BIN conversion	#0=BIN(#1)	2.0
			D800=BIN(D801)	
			U3E1\G10000=BIN(U3E1\G10001)	
			#0L=BIN(#2L)	2.5
			D800L=BIN(D802L)	
	U3E1\G10000L=BIN(U3E1\G10002L)	3.0		
	BCD	BIN→BCD conversion	#0=BCD(#1)	2.0
			D800=BCD(D801)	3.0
			U3E1\G10000=BCD(U3E1\G10001)	
			#0L=BCD(#2L)	
D800L=BCD(D802L)			2.5	
U3E1\G10000L=BCD(U3E1\G10002L)	3.5			
Type conversion	SHORT	Converted into 16-bit integer type (signed)	#0=SHORT(#2L)	2.0
			D800=SHORT(D802L)	
			U3E1\G10000=SHORT(U3E1\G10002L)	
			#0=SHORT(#4F)	2.5
			D800=SHORT(D804F)	
	U3E1\G10000=SHORT(U3E1\G10004F)	3.5		
	USHORT	Converted into 16-bit integer type (unsigned)	#0=USHORT(#2L)	2.0
			D800=USHORT(D802L)	
			U3E1\G10000=USHORT(U3E1\G10002L)	
			#0=USHORT(#4F)	2.5
			D800=USHORT(D804F)	
	U3E1\G10000=USHORT(U3E1\G10004F)	3.5		
	LONG	Converted into 32-bit integer type (signed)	#0L=LONG(#2)	2.0
			D800L=LONG(D802)	
			U3E1\G10000L=LONG(U3E1\G10002)	
			#0L=LONG(#4F)	3.0
			D800L=LONG(D804F)	
	U3E1\G10000L=LONG(U3E1\G10004F)	3.5		
	ULONG	Converted into 32-bit integer type (unsigned)	#0L=ULONG(#2)	2.0
			D800L=ULONG(D802)	
			U3E1\G10000L=ULONG(U3E1\G10002)	
			#0L=ULONG(#4F)	3.0
			D800L=ULONG(D804F)	
	U3E1\G10000L=ULONG(U3E1\G10004F)	4.0		
FLOAT	Converted into 64-bit floating point type (signed)	#0F=FLOAT(#4)	2.0	
		D800F=FLOAT(D804)		
		U3E1\G10000F=FLOAT(U3E1\G10004)		
		#0F=FLOAT(#4L)	2.0	
		D800F=FLOAT(D804L)		
U3E1\G10000F=FLOAT(U3E1\G10004L)	3.0			
UFLOAT	Converted into 64-bit floating point type (unsigned)	#0F=UFLOAT(#4)	2.0	
		D800F=UFLOAT(D804)		
		U3E1\G10000F=UFLOAT(U3E1\G10004)		
		#0F=UFLOAT(#4L)	2.0	
		D800F=UFLOAT(D804L)		
U3E1\G10000F=UFLOAT(U3E1\G10004L)	2.5			

Processing time of operation instructions (continued)

Classifications	Symbol	Instruction	Operation expression	Processing time [μ s] Q170MCPU		
Bit device status	(None)	ON (normally open contact) (Completion of condition)	SET M1000 = M0	2.5		
			SET M1000 = X100	3.5		
			SET M1000 = PX0	7.5		
			SET M1000 = U3E1\G10000.0	3.5		
	!	OFF (normally closed contact) (Completion of condition)	SET M1000 = !M0	3.0		
			SET M1000 = !X100	7.0		
			SET M1000 = !PX0	5.0		
			SET M1000 = !U3E1\G10000.0	3.0		
Bit device control	SET	Device set	SET M1000	2.0		
			SET Y100	2.5		
			SET PY0			
			SET U3E1\G11000.0			
	RST	Device reset	RST M1000	2.0		
			RST Y100	2.5		
			RST PY0			
			RST U3E1\G11000.0	3.0		
	DOUT	Device output	DOUT M0,#0	3.0		
			DOUT M0,#0L	2.5		
			DOUT Y100,#0			
			DOUT Y100,#0L	4.0		
			DOUT PY0,#0	3.0		
			DOUT PY0,#0L	4.5		
			DIN	Device input	DIN #0,M0	3.0
					DIN #0L,M0	
	DIN #0,X0	2.5				
	DIN #0L,X0	3.0				
	DIN #0,PX0	8.0				
	DIN #0L,PX0	10.5				
	OUT	Bit device output	OUT M100 = M0	2.5		
			OUT Y0 = M0	3.0		
			OUT PY0 = M0	3.5		
			OUT U3E1\G10000.0 = M0			
Logical operation	*	Logical AND	SET M1000 = M0*M1	3.0		
			SET M1000 = X100*X101	4.0		
			SET M1000 = PX0*PX1	10.0		
			SET M1000 = U3E1\G10000.0*U3E1\G10000.1	3.5		
	+	Logical OR	SET M1000 = M0+M1	3.0		
			SET M1000 = X100+X101	3.5		
			SET M1000 = PX0+PX1	11.0		
			SET M1000 = U3E1\G10000.0+U3E1\G10000.1	3.5		

Processing time of operation instructions (continued)

Classifications	Symbol	Instruction	Operation expression	Processing time [μs] Q170MCPU
Comparison operation	==	Equal to (Completion of condition)	SET M1000 = #0==#1	3.5
			SET M1000 = D800==D801	
			SET M1000 = U3E1\G10000==U3E1\G10001	4.5
			SET M1000 = #0L==#2L	
			SET M1000 = D800L==D802L	4.0
			SET M1000 = U3E1\G10000L==U3E1\G10002L	
			SET M1000 = #0F==#4F	4.5
			SET M1000 = D800F==D804F	
	SET M1000 = U3E1\G10000F==U3E1\G10004F	6.0		
	!=	Not equal to (Completion of condition)	SET M1000 = #0!=#1	4.0
			SET M1000 = D800!=D801	
			SET M1000 = U3E1\G10000!=U3E1\G10001	4.5
			SET M1000 = #0L!=#2L	
			SET M1000 = D800L!=D802L	4.0
			SET M1000 = U3E1\G10000L!=U3E1\G10002L	
			SET M1000 = #0F!=#4F	4.5
			SET M1000 = D800F!=D804F	
	SET M1000 = U3E1\G10000F!=U3E1\G10004F	6.0		
	<	Less than (Completion of condition)	SET M1000 = #0<#1	4.0
			SET M1000 = D800<D801	
			SET M1000 = U3E1\G10000<U3E1\G10001	4.5
			SET M1000 = #0L<#2L	
			SET M1000 = D800L<D802L	4.0
			SET M1000 = U3E1\G10000L<U3E1\G10002L	
			SET M1000 = #0F<#4F	4.5
			SET M1000 = D800F<D804F	
	SET M1000 = U3E1\G10000F<U3E1\G10004F	6.0		
	<=	Less than or equal to (Completion of condition)	SET M1000 = #0<=#1	3.5
			SET M1000 = D800<=D801	
			SET M1000 = U3E1\G10000<=U3E1\G10001	4.5
			SET M1000 = #0L<=#2L	
			SET M1000 = D800L<=D802L	4.0
SET M1000 = U3E1\G10000L<=U3E1\G10002L				
SET M1000 = #0F<=#4F			4.5	
SET M1000 = D800F<=D804F				
SET M1000 = U3E1\G10000F<=U3E1\G10004F	6.0			
>	More than (Completion of condition)	SET M1000 = #0>#1	4.0	
		SET M1000 = D800>D801		
		SET M1000 = U3E1\G10000>U3E1\G10001	4.5	
		SET M1000 = #0L>#2L		
		SET M1000 = D800L>D802L	4.0	
		SET M1000 = U3E1\G10000L>U3E1\G10002L		
		SET M1000 = #0F>#4F	4.5	
		SET M1000 = D800F>D804F		
SET M1000 = U3E1\G10000F>U3E1\G10004F	6.0			

Processing time of operation instructions (continued)

Classifications	Symbol	Instruction	Operation expression	Processing time [μs] Q170MCPU
Comparison operation	>=	More than or equal to (Completion of condition)	SET M1000 = #0>=#1	4.0
			SET M1000 = D800>=D801	
			SET M1000 = U3E1\G10000>=U3E1\G10001	4.5
			SET M1000 = #0L>=#2L	
			SET M1000 = D800L>=D802L	5.0
			SET M1000 = U3E1\G10000L>=U3E1\G10002L	
			SET M1000 = #0F>=#4F	4.5
			SET M1000 = D800F>=D804F	
SET M1000 = U3E1\G10000F>=U3E1\G10004F	6.0			
Motion dedicated function	CHGV	Speed change request	CHGV(K1,#0)	3.5
			CHGV(K1,D800)	
			CHGV(K1,U3E1\G10000)	4.5
			CHGV(K1,#0L)	3.5
			CHGV(K1,D800L)	
	CHGV(K1,U3E1\G10000L)			
	CHGT	Torque limit value change request	CHGT(K1,#0)	2.0
			CHGT(K1,D800)	
			CHGT(K1,U3E1\G10000)	2.5
			CHGT(K1,#0L)	
CHGT(K1,D800L)				
CHGT(K1,U3E1\G10000L)	3.0			
Others	EI	Event task enable	EI	0.5
	DI	Event task disable	DI	0.5
	NOP	No operation	NOP	0.5
	BMOV	Block transfer	BMOV #0,#100,K10	5.5
			BMOV D800,D100,K10	
			BMOV U3E1\G10000,U3E1\G10100,K10	7.5
			BMOV #0,#100,K100	19.0
			BMOV D800,D100,K100	
			BMOV U3E1\G10000,U3E1\G10100,K100	28.0
			BMOV N1,#0,K512	123.5
			BMOV N1,D800,K512	
	BMOV N1,U3E1\G10000,K512	250.5		
	FMOV	Same data block transfer	FMOV #0,#100,K10	3.5
			FMOV D800,D100,K10	
			FMOV U3E1\G10000,U3E1\G10100,K10	4.0
			FMOV #0,#100,K100	7.5
			FMOV D800,D100,K100	
FMOV U3E1\G10000,U3E1\G10100,K100	5.0			
MULTW	Write device data to CPU shared memory of the self CPU	MULTW H800,#0,K1,M0	4.0	
		MULTW H800,D800,K1,M0		
		MULTW H800,U3E1\G10000,K1,M0	5.0	
		MULTW H800,#0,K10,M0	5.5	
		MULTW H800,D800,K10,M0		
		MULTW H800,U3E1\G10000,K10,M0	9.5	
		MULTW H800,#0,K100,M0	23.5	
		MULTW H800,D800,K100,M0		
MULTW H800,U3E1\G10000,K100,M0	61.0			

Processing time of operation instructions (continued)

Classifications	Symbol	Instruction	Operation expression	Processing time [μs] Q170MCPU
Others	MULTW	Write device data to CPU shared memory of the self CPU	MULTW H800,#0,K256,M0	58.0
			MULTW H800,D800,K256,M0	
			MULTW H800,U3E1\G10000,K256,M0	151.5
	MULTR	Read device data from CPU shared memory	MULTR #0,H3E0,H800,K1	20.5
			MULTR D800,H3E0,H800,K1	
			MULTR U3E1\G10000,H3E0,H800,K1	22.0
			MULTR #0,H3E0,H800,K10	30.5
			MULTR D800,H3E0,H800,K10	
			MULTR U3E1\G10000,H3E0,H800,K10	31.5
			MULTR #0,H3E0,H800,K100	140.5
			MULTR D800,H3E0,H800,K100	
			MULTR U3E1\G10000,H3E0,H800,K100	152.0
			MULTR #0,H3E0,H800,K256	412.0
			MULTR D800,H3E0,H800,K256	
	MULTR U3E1\G10000,H3E0,H800,K256	435.0		
	TO	Write device data to intelligent function module	TO H0,H0,#0,K1	18.5
			TO H0,H0,D800,K1	
			TO H0,H0,U3E1\G10000,K1	20.5
			TO H0,H0,#0,K10	28.0
			TO H0,H0,D800,K10	
			TO H0,H0,U3E1\G10000,K10	30.5
			TO H0,H0,#0,K100	145.5
			TO H0,H0,D800,K100	
			TO H0,H0,U3E1\G10000,K100	183.0
			TO H0,H0,#0,K256	432.0
			TO H0,H0,D800,K256	
	TO H0,H0,U3E1\G10000,K256	545.0		
	FROM	Read device data from intelligent function module	FROM #0,H0,H0,K1	20.0
			FROM D800,H0,H0,K1	
			FROM U3E1\G10000,H0,H0,K1	19.5
			FROM #0,H0,#0,K10	30.0
			FROM D800,H0,H0,K10	
			FROM U3E1\G10000,H0,H0,K10	33.5
			FROM #0,H0,#0,K100	188.0
			FROM D800,H0,H0,K100	
			FROM U3E1\G10000,H0,H0,K100	200.5
			FROM #0,H0,H0,K256	559.0
			FROM D800,H0,H0,K256	
	FROM U3E1\G10000,H0,H0,K256	577.5		
	TIME	Time to wait	TIME K1	2.5
			TIME #0	
			TIME D800	
TIME U3E1\G10000			3.5	

(2) Transition conditional expressions

Processing time of transition conditional expressions

Classifications	Symbol	Instruction	Operation expression	Processing time [μs] Q170MCPU
Bit device status	(None)	ON (Normally open contact) (Completion of condition)	M0	1.0
			X100	
			PX0	4.5
			U3E1\G10000.0	1.5
	!	OFF (Normally closed contact) (Completion of condition)	!M0	1.5
			!X100	
			!PX0	4.5
			!U3E1\G10000.0	1.5
Logical operation	*	Logical AND	M0*M1	2.0
			X100*X101	
			PX0*PX1	8.0
			U3E1\G10000.0*U3E1\G10000.1	2.5
	+	Logical OR	M0+M1	1.5
			X100+X101	2.0
			PX0+PX1	8.5
			U3E1\G10000.0+U3E1\G10000.1	2.5
Comparison operation	==	Equal to (Completion of condition)	#0==#1	1.5
			D800==D801	
			U3E1\G10000==U3E1\G10001	2.5
			#0L==#2L	2.0
			D800L==D802L	
			U3E1\G10000L==U3E1\G10002L	2.5
			#0F==#4F	
			D800F==D804F	4.0
	U3E1\G10000F==U3E1\G10004F			
	!=	Not equal to (Completion of condition)	#0!=#1	1.5
			D800!=D801	
			U3E1\G10000!=U3E1\G10001	2.5
			#0L!=#2L	1.5
			D800L!=D802L	
			U3E1\G10000L!=U3E1\G10002L	2.5
			#0F!=#4F	2.0
D800F!=D804F				
U3E1\G10000F!=U3E1\G10004F	3.5			
<	Less than (Completion of condition)	#0<#1	1.5	
		D800<D801		
		U3E1\G10000<U3E1\G10001	2.5	
		#0L<#2L	2.0	
		D800L<D802L		
		U3E1\G10000L<U3E1\G10002L	2.5	
		#0F<#4F	2.0	
		D800F<D804F		
U3E1\G10000F<U3E1\G10004F	3.5			

Processing time of transition conditional expressions (continued)

Classifications	Symbol	Instruction	Operation expression	Processing time [μs] Q170MCPU
Comparison operation	<=	Less than or equal to (Completion of condition)	#0<=#1	1.5
			D800<=D801	
			U3E1\G10000<=U3E1\G10001	
			#0L<=#2L	1.5
			D800L<=D802L	
			U3E1\G10000L<=U3E1\G10002L	
			#0F<=#4F	2.5
			D800<=D804F	
			U3E1\G10000F<=U3E1\G10004F	
	>	More than (Completion of condition)	#0>#1	1.5
			D800>D801	
			U3E1\G10000>U3E1\G10001	
			#0L>#2L	1.5
			D800L>D802L	
			U3E1\G10000L>U3E1\G10002L	
			#0F>#4F	2.0
			D800F>D804F	
	U3E1\G10000F>U3E1\G10004F			
	>=	More than or equal to (Completion of condition)	#0>=#1	2.0
			D800>=D801	
			U3E1\G10000>=U3E1\G10001	
#0L>=#2L			1.5	
D800L>=D802L				
U3E1\G10000L>=U3E1\G10002L				
#0F>=#4F			2.0	
D800F>=D804F				
U3E1\G10000F>=U3E1\G10004F				

(3) Processing time by the combination F and G (program described in F/G is NOP)

	F alone	G alone	F+G	G SUB	CLR	JMP/coupling
Processing time [μ s] Q170M CPU	14.0	13.5	15.5	22.0	14.5	4.5

(Note): Varies greatly with the started or cleared program.

	Parallel branch (2 Pcs.)		Parallel branch (5 Pcs.)	
	At branch	At coupling	At branch	At coupling
Processing time [μ s] Q170M CPU	23.0	18.5	49.0	32.5

	Selective branch (2 Pcs.)	Selective branch (5 Pcs.)
Processing time [μ s] Q170M CPU	48.0	55.0

POINT
<p>Long processing time may cause a Motion CPU WDT error or servo fault. Especially for the Motion SFC programs run by event/NMI tasks, take care so that the processing time will not be too long (the processing time will not exceed the operation cycle).</p>

APPENDICES

APPENDIX 3.2 Processing time of Motion dedicated PLC instruction

Processing time of Motion dedicated PLC instruction

Classifications	Symbol	Instruction (Condition)	Processing time [μs] Q170MCPUCPU (PLC CPU area)		
			Min.	Max.	
Multiple CPU high speed bus Motion dedicated instruction	D.SFCS	Start request of the specified Motion SFC program	62.0	95.0	
	D.SVST	Start request of the specified servo program	82.0	122.0	
	D.CHGA	Current value change request of the specified axis	82.0	122.0	
	D.CHGV	Speed change request of the specified axis	82.0	122.0	
	D.CHGT	Torque control value change request of the specified axis	82.0	122.0	
Multiple CPU high speed bus other CPU access instruction	D.DDWR	Write device data of the self CPU to the device of other CPU	Number of writing data = 1	76.0	126.0
			Number of writing data = 16	91.0	142.0
	D.DDRD	Read device data of other CPU to the device of self CPU	Number of reading data = 1	82.0	133.0
			Number of reading data = 16	82.0	133.0
	D.GINT	Execute request of an event task of Motion SFC program	50.0	80.0	

APPENDICES

APPENDIX 4 Cables

In this cable connection diagram, maker names of connectors are omitted. Refer to "APPENDIX 5.5 Connector" for maker names of connectors.

APPENDIX 4.1 SSCNET III cables

Generally use the SSCNET III cables available as our products.

(1) Model explanation

Numeral in the column of cable length on the table is a symbol put in the "□" part of cable model. Cables of which symbol exists are available.

Cable model	Cable length [m(ft.)]											Flex life	Application/remark
	0.15 (0.49)	0.3 (0.98)	0.5 (1.64)	1 (3.28)	3 (9.84)	5 (16.40)	10 (32.81)	20 (65.62)	30 (98.43)	40 (131.23)	50 (164.04)		
MR-J3BUS□M	015	03	05	1	3	/	/	/	/	/	/	Standard	Standard cord for inside panel
MR-J3BUS□M-A	/	/	/	/	/	5	10	20	/	/	/	Standard	Standard cable for outside panel
MR-J3BUS□M-B (Note-1)	/	/	/	/	/	/	/	/	30	40	50	Long flex	Long distance cable

(Note-1) : For the cable of less than 30[m](98.43[ft.]), contact your nearest Mitsubishi sales representative.

(2) Specifications

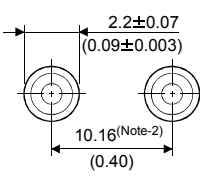
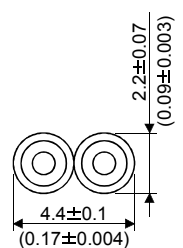
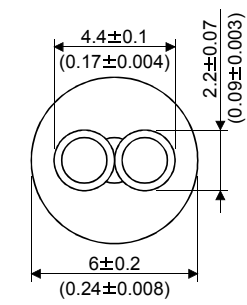
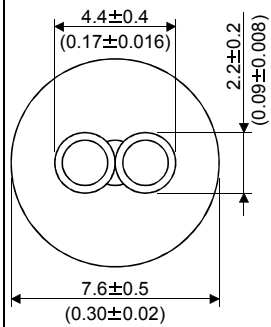
		Description			
SSCNET III cable model		MR-J3BUS□M		MR-J3BUS□M-A	MR-J3BUS□M-B
SSCNET III cable length [m(ft.)]		0.15 (0.49)	0.3 to 3 (0.98 to 9.84)	5 to 20 (16.40 to 65.62)	30 to 50 (98.43 to 164.04)
Optical cable (Cord)	Minimum bend radius [mm(inch)]	25(0.98)		Enforced covering cord: 50 (1.97) Cord: 25 (0.98)	Enforced covering cord: 50 (1.97) Cord: 30(1.18)
	Tension strength [N]	70	140	420 (Enforced covering cord)	980 (Enforced covering cord)
	Temperature range for use [°C(°F)] (Note-1)	-40 to 80 (-40 to 176)			-20 to 70 (-4 to 158)
	Ambient	Indoors (no direct sunlight), No solvent or oil			
	External appearance [mm(inch)]				

(Note-1): This temperature range for use is the value for optical cable (cord) only.

(Note-2): Dimension of connector fiber insert location. The distance of two cords is changed by how to bend it.

POINTS	
(1)	If the end face of cord tip for the SSCNETⅢ cable is dirty, optical transmission is interrupted and it may cause malfunctions. If it becomes dirty, wipe with a bonded textile, etc. Do not use solvent such as alcohol.
(2)	Do not add impossible power to the connector of the SSCNETⅢ cable.
(3)	When incinerating the SSCNETⅢ cable (optical fiber), hydrogen fluoride gas or hydrogen chloride gas which is corrosive and harmful may be generated. For disposal of the SSCNETⅢ cable (optical fiber), request for specialized industrial waste disposal services who has incineration facility for disposing hydrogen fluoride gas or hydrogen chloride gas.

(a) MR-J3BUS□M

1) Model explanation

Type: MR-J3BUS□M-*

Symbol	Cable type
None	Standard cord for inside panel
A	Standard cable for outside panel
B	Long distance cable

Symbol	Cable length [m(ft.)]
015	0.15(0.49)
03	0.3(0.98)
05	0.5(1.64)
1	1(3.28)
3	3(9.84)
5	5(16.40)
10	10(32.81)
20	20(65.62)
30	30(98.43)
40	40(131.23)
50	50(164.04)

2) Exterior dimensions

• MR-J3BUS015M

[Unit: mm(inch)]

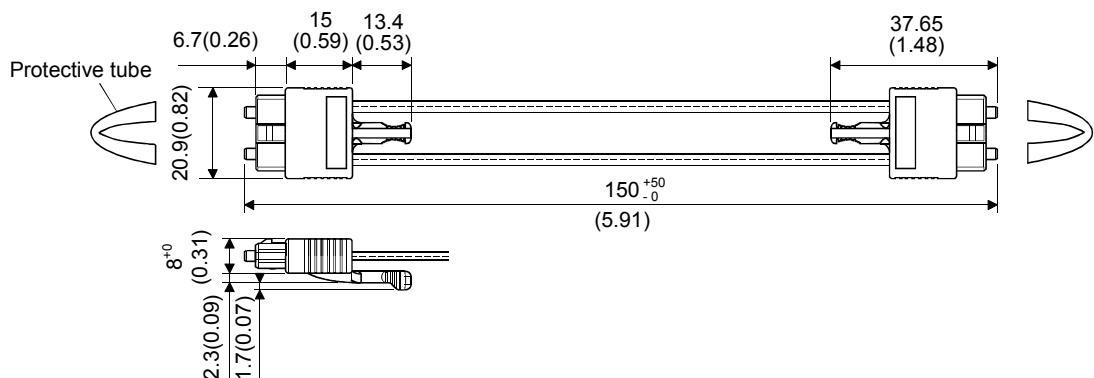

• MR-J3BUS03M to MR-J3BUS3M

Refer to the table of this section (1) for cable length (L).

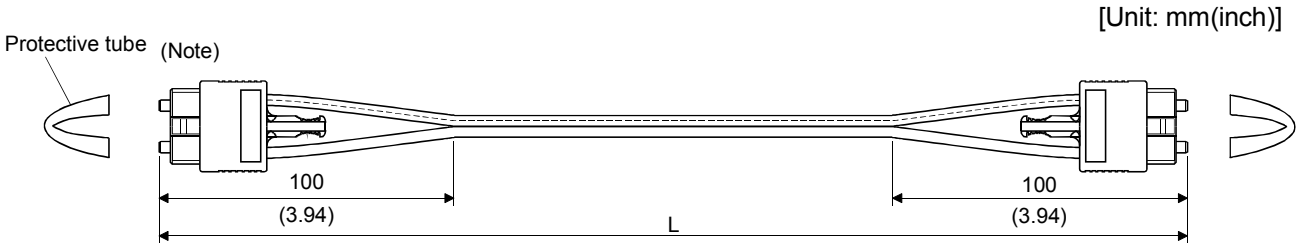

(Note) : Dimension of connector part is the same as that of MR-J3BUS015M.

• MR-J3BUS5M-A to MR-J3BUS20M-A, MR-J3BUS30M-B to MR-J3BUS50M-B

Refer to the table of this section (1) for cable length (L).

SSCNETⅢ cable	Variation [mm(inch)]	
	A	B
MR-J3BUS5M-A to MR-J3BUS20M-A	100(3.94)	30(1.18)
MR-J3BUS30M-B to MR-J3BUS50M-B	150(5.91)	50(1.97)

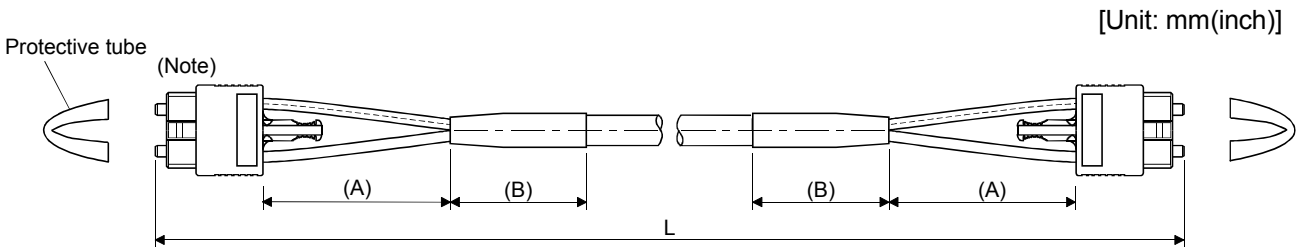

(Note) : Dimension of connector part is the same as that of MR-J3BUS015M.

POINTS

Keep the cap and the tube for protecting light cord end of SSCNETⅢ cable in a plastic bag with a zipper of SSCNETⅢ cable to prevent them from becoming dirty.

APPENDIX 4.2 Forced stop input cable

Generally use the forced stop input cable available as our products. If the required length is not found in our products, fabricate the cable on the customer side. Make the forced stop input cable within 30m(98.43ft.).

- (1) Q170DEMICBL□M
 - (a) Model explanation

Type : Q170DEMICBL□M

Symbol	Cable length [m(ft.)]
05	0.5(1.64)
1	1(3.28)
3	3(9.84)
5	5(16.40)
10	10(32.81)
15	15(49.21)
20	20(65.62)
25	25(82.02)
30	30(98.43)

- (b) Connection diagram

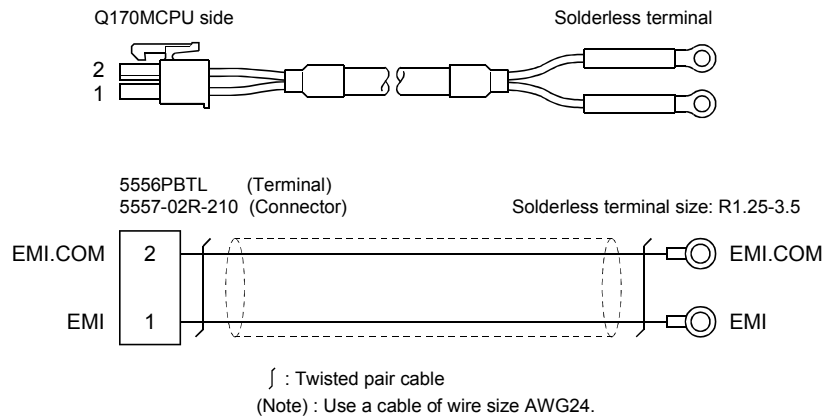

APPENDIX 4.3 24VDC power supply cable

Fabricate the 24VDC power supply cable on the customer side.

(1) Connection diagram

(a) Without EMI terminal

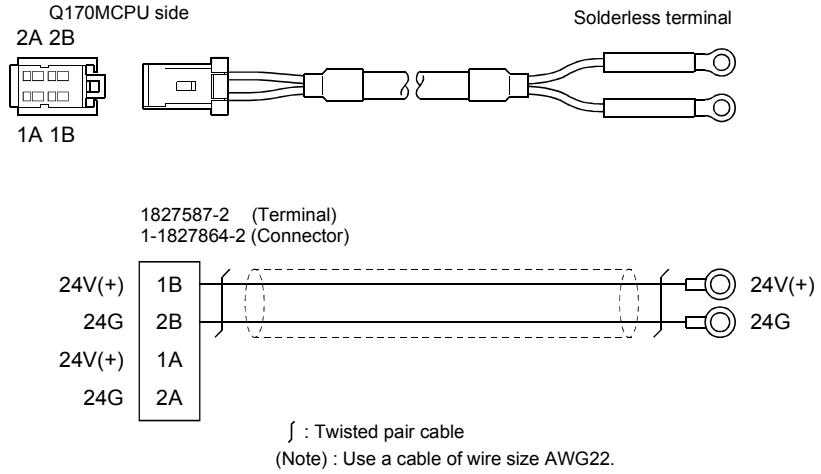

(b) With EMI terminal

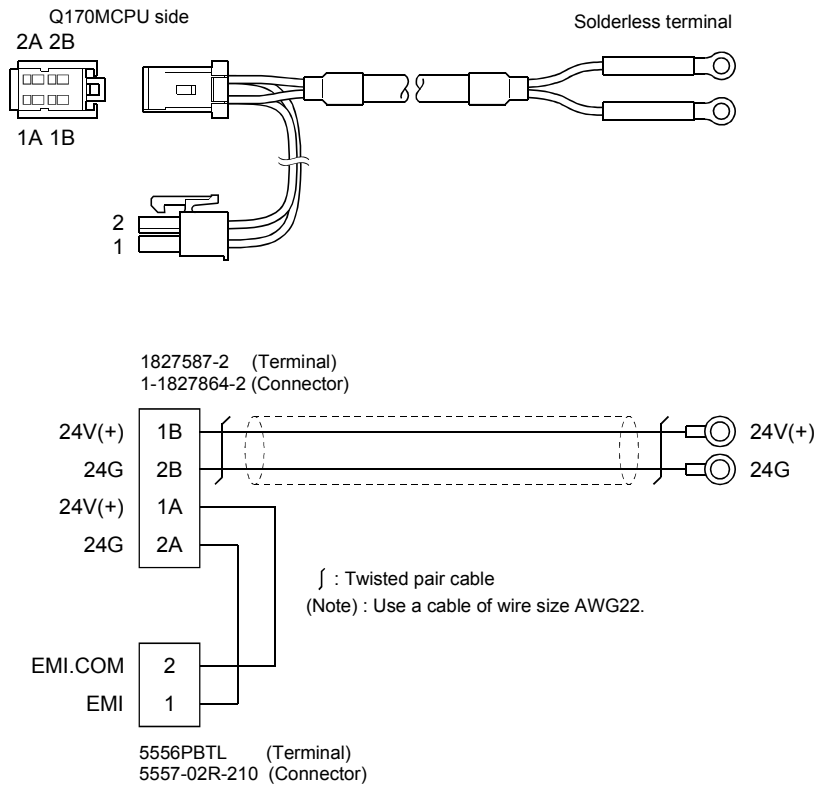

APPENDICES

APPENDIX 5 Exterior Dimensions

APPENDIX 5.1 Motion controller (Q170MCPU)

[Unit: mm (inch)]

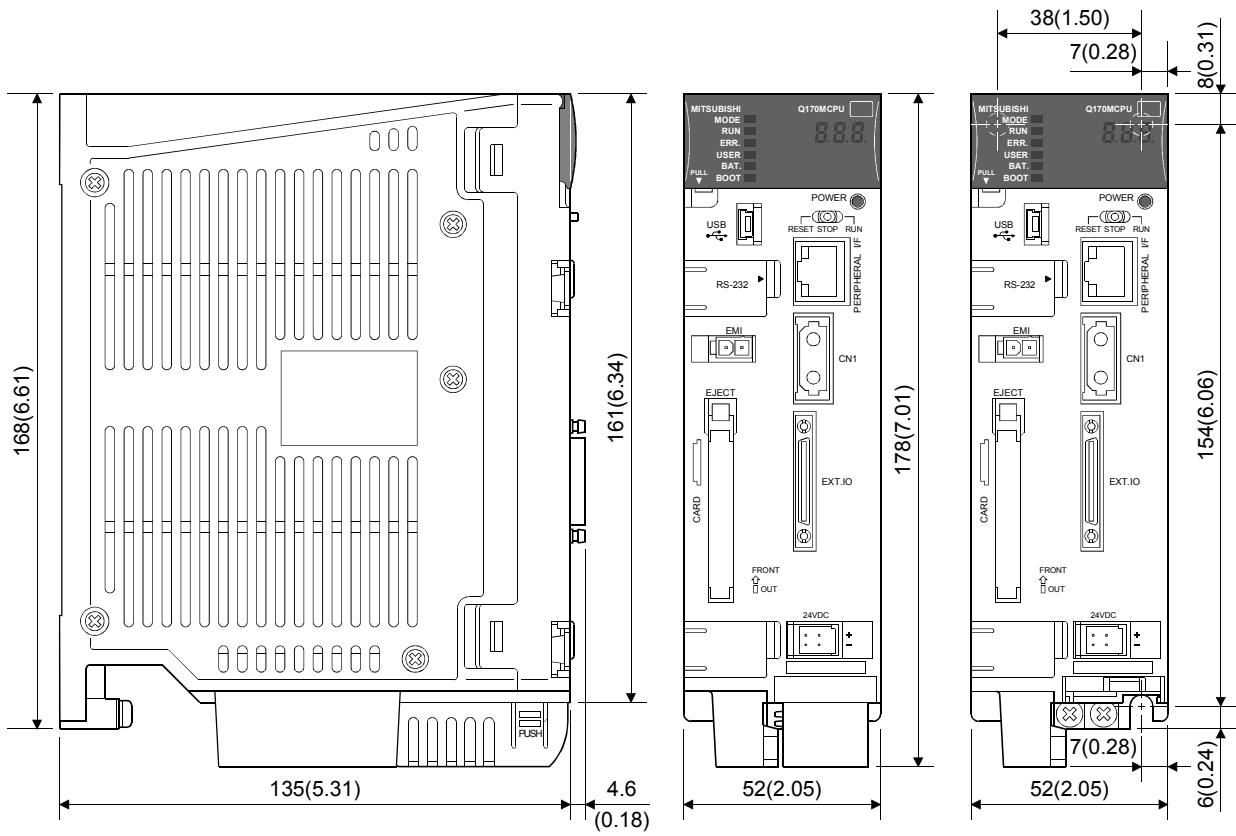

APPENDICES

APPENDIX 5.2 Servo external signals interface module (Q172DLX)

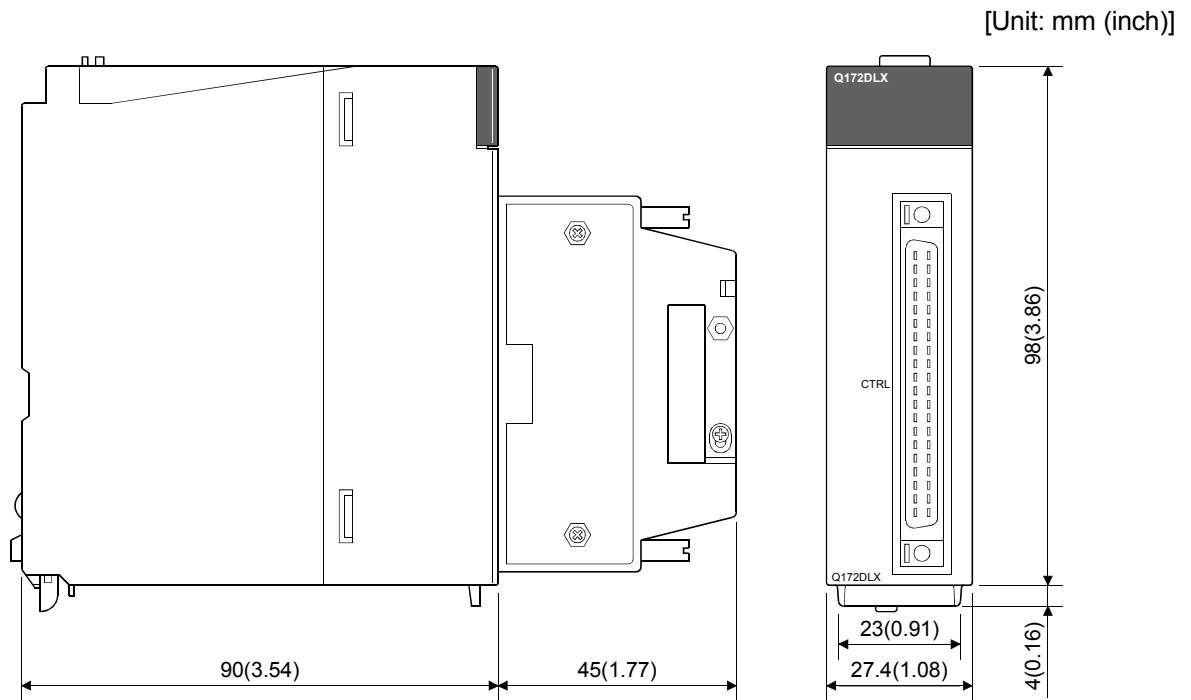

APPENDIX 5.3 Manual pulse generator interface module (Q173DPX)

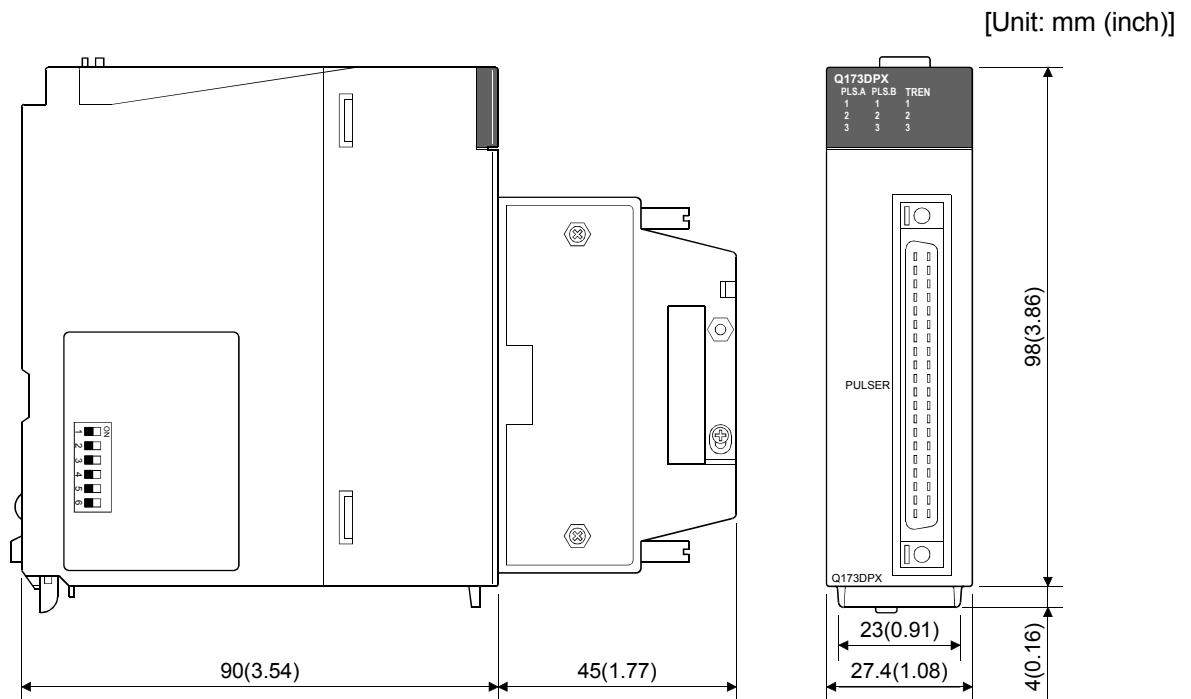

APPENDIX 5.4 Battery holder

(1) Battery holder (For Q6BAT)

[Unit: mm (inch)]

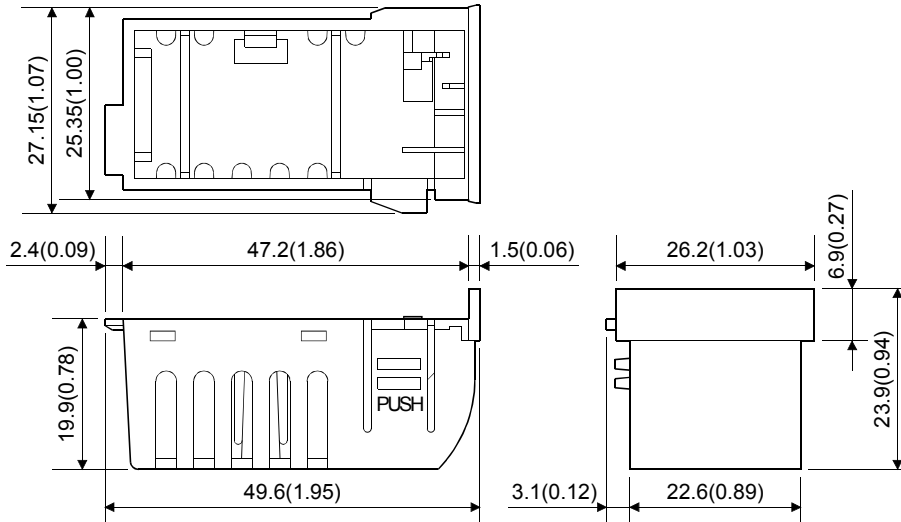

(2) Battery holder (For Q7BAT)

[Unit: mm (inch)]

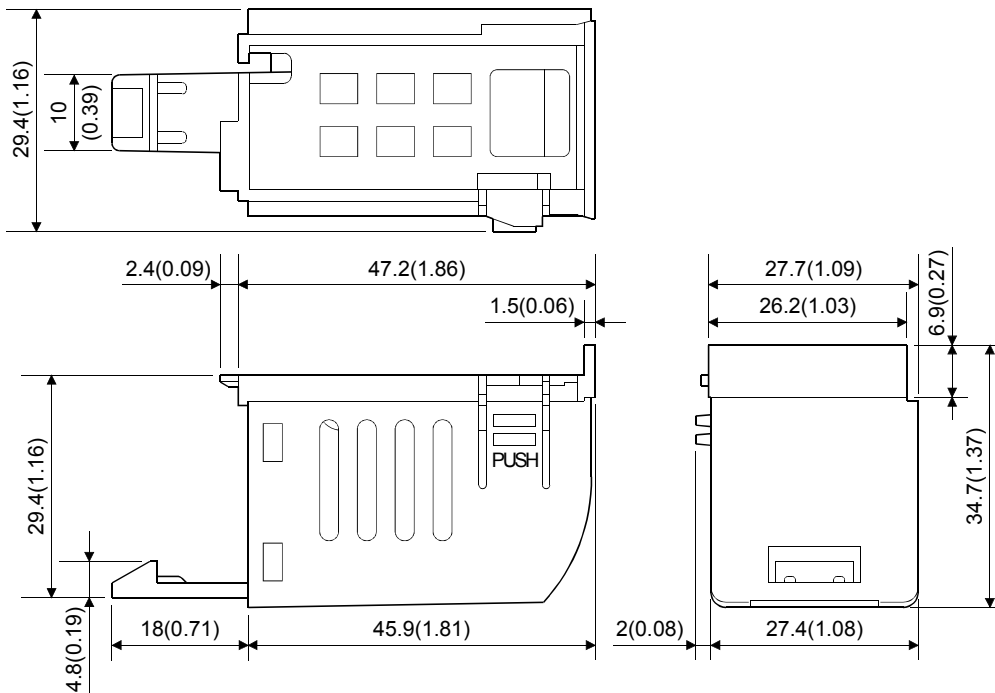

APPENDIX 5.5 Connector

(1) SSCNET III cable connector

[Unit: mm (inch)]

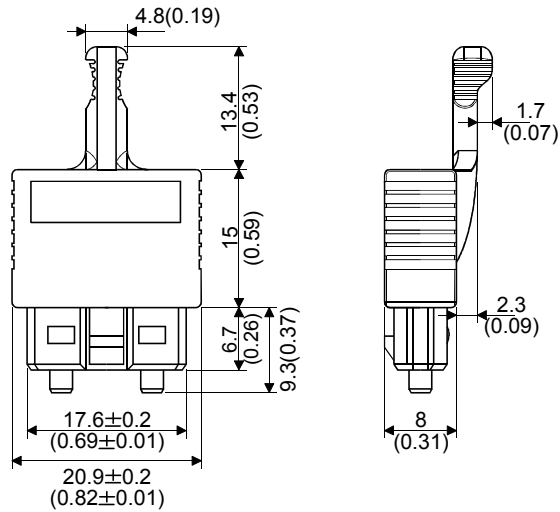

(2) Forced stop input connector (Molex Incorporated make)

Type Connector : 5557-02R-210

Terminal : 5556PBTB

[Unit: mm (inch)]

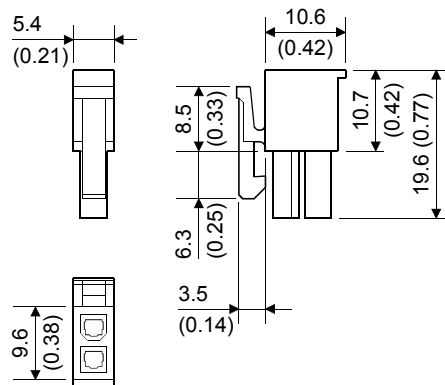

APPENDICES

(3) 24VDC power supply connector (Tyco Electronics AMP K.K. make)

Type Connector : 1-1827864-2

Terminal : 1827587-2

[Unit: mm (inch)]

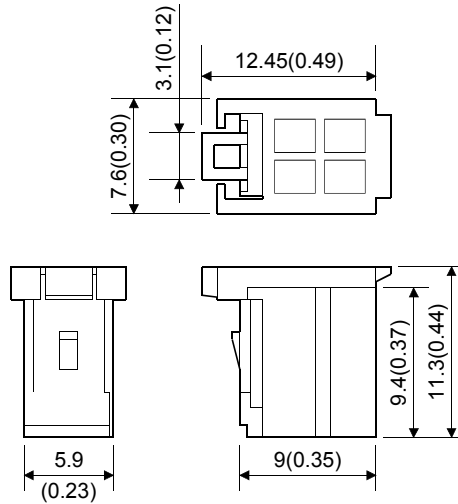

APPENDIX 5.6 Manual pulse generator (MR-HDP01)

[Unit: mm (inch)]

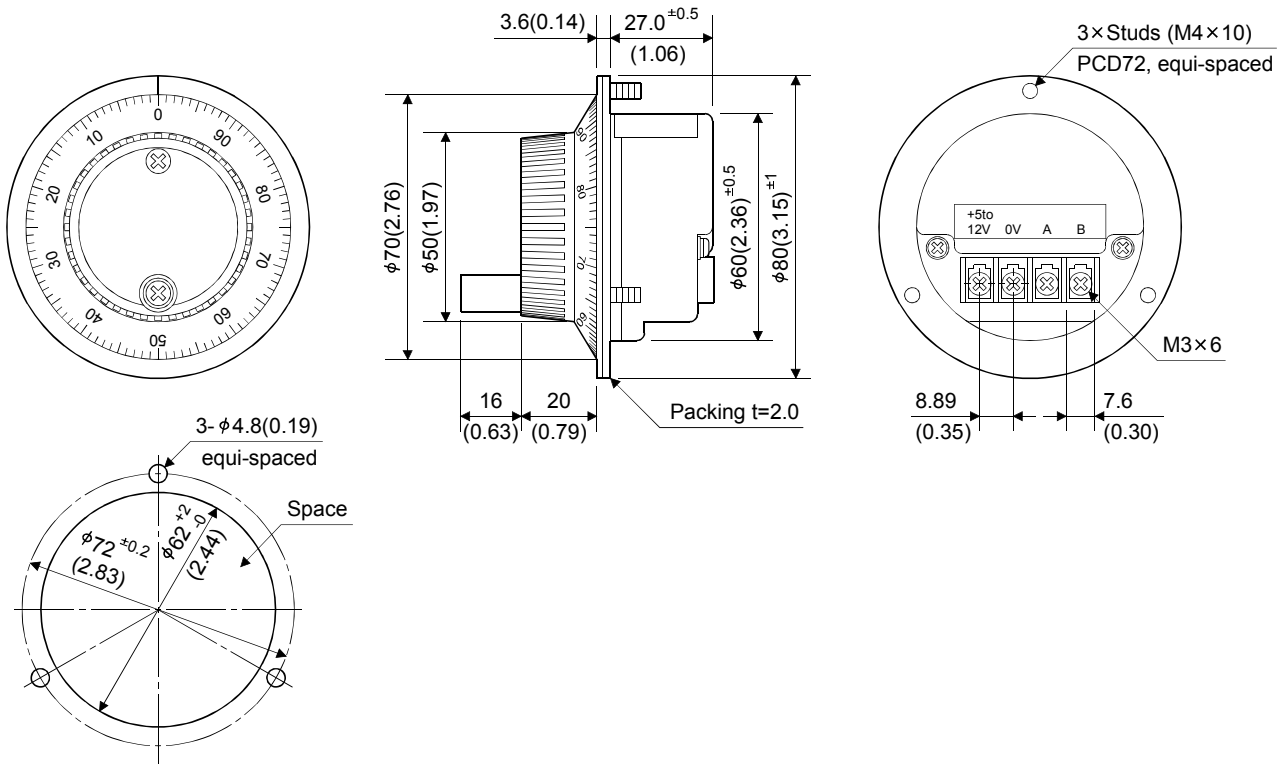

The figure of processing a disc

WARRANTY

Please confirm the following product warranty details before using this product.

1. Gratis Warranty Term and Gratis Warranty Range

We will repair any failure or defect hereinafter referred to as "failure" in our FA equipment hereinafter referred to as the "Product" arisen during warranty period at no charge due to causes for which we are responsible through the distributor from which you purchased the Product or our service provider. However, we will charge the actual cost of dispatching our engineer for an on-site repair work on request by customer in Japan or overseas countries. We are not responsible for any on-site readjustment and/or trial run that may be required after a defective unit are repaired or replaced.

[Gratis Warranty Term]

The term of warranty for Product is thirty six (36) months after your purchase or delivery of the Product to a place designated by you or forty two (42) months from the date of manufacture whichever comes first "Warranty Period". Warranty period for repaired Product cannot exceed beyond the original warranty period before any repair work.

[Gratis Warranty Range]

- (1) You are requested to conduct an initial failure diagnosis by yourself, as a general rule.
It can also be carried out by us or our service company upon your request and the actual cost will be charged. However, it will not be charged if we are responsible for the cause of the failure.
- (2) This limited warranty applies only when the condition, method, environment, etc. of use are in compliance with the terms and conditions and instructions that are set forth in the instruction manual and user manual for the Product and the caution label affixed to the Product.
- (3) Even during the term of warranty, the repair cost will be charged on you in the following cases;
 - 1) A failure caused by your improper storing or handling, carelessness or negligence, etc., and a failure caused by your hardware or software problem
 - 2) A failure caused by any alteration, etc. to the Product made on your side without our approval
 - 3) A failure which may be regarded as avoidable, if your equipment in which the Product is incorporated is equipped with a safety device required by applicable laws and has any function or structure considered to be indispensable according to a common sense in the industry
 - 4) A failure which may be regarded as avoidable if consumable parts designated in the instruction manual, etc. are duly maintained and replaced
 - 5) Any replacement of consumable parts (battery, fan, etc.)
 - 6) A failure caused by external factors such as inevitable accidents, including without limitation fire and abnormal fluctuation of voltage, and acts of God, including without limitation earthquake, lightning and natural disasters
 - 7) A failure generated by an unforeseeable cause with a scientific technology that was not available at the time of the shipment of the Product from our company
 - 8) Any other failures which we are not responsible for or which you acknowledge we are not responsible for

2. Onerous Repair Term after Discontinuation of Production

- (1) We may accept the repair at charge for another seven (7) years after the production of the product is discontinued.
The announcement of the stop of production for each model can be seen in our Sales and Service, etc.
- (2) Please note that the Product (including its spare parts) cannot be ordered after its stop of production.

3. Service in overseas countries

Our regional FA Center in overseas countries will accept the repair work of the Product; However, the terms and conditions of the repair work may differ depending on each FA Center. Please ask your local FA center for details.

4. Exclusion of Loss in Opportunity and Secondary Loss from Warranty Liability

Whether under or after the term of warranty, we assume no responsibility for any damages arisen from causes for which we are not responsible, any losses of opportunity and/or profit incurred by you due to a failure of the Product, any damages, secondary damages or compensation for accidents arisen under a specific circumstance that are foreseen or unforeseen by our company, any damages to products other than the Product, and also compensation for any replacement work, readjustment, start-up test run of local machines and the Product and any other operations conducted by you.

5. Change of Product specifications

Specifications listed in our catalogs, manuals or technical documents may be changed without notice.

6. Precautions for Choosing the Products

- (1) For the use of our Motion controller, its applications should be those that may not result in a serious damage even if any failure or malfunction occurs in Motion controller, and a backup or fail-safe function should operate on an external system to Motion controller when any failure or malfunction occurs.
- (2) Our Motion controller is designed and manufactured as a general purpose product for use at general industries. Therefore, applications substantially influential on the public interest for such as atomic power plants and other power plants of electric power companies, and also which require a special quality assurance system, including applications for railway companies and government or public offices are not recommended, and we assume no responsibility for any failure caused by these applications when used.

In addition, applications which may be substantially influential to human lives or properties for such as airlines, medical treatments, railway service, incineration and fuel systems, man-operated material handling equipment, entertainment machines, safety machines, etc. are not recommended, and we assume no responsibility for any failure caused by these applications when used.

We will review the acceptability of the abovementioned applications, if you agree not to require a specific quality for a specific application. Please contact us for consultation.

MOTION CONTROLLER Qseries

User's Manual (Q170MCPU)



HEAD OFFICE : TOKYO BUILDING, 2-7-3 MARUNOUCHI, CHIYODA-KU, TOKYO 100-8310, JAPAN

MODEL	Q170M-U-E
MODEL CODE	1XB941
IB(NA)-0300156-A(0902)MEE	

When exported from Japan, this manual does not require application to the Ministry of Economy, Trade and Industry for service transaction permission.