

Pro-face

by Schneider Electric

GP4000 Series Rear Mount Model Installation Guide



Please read the “Warning/Caution Information” on the attached sheet before using the product.

Overview

Package Contents.....	4
About the Manual.....	5
Global Code.....	5

Electrical Specifications

1. PFXGP4301TADR/PFXGP4401TADR.....	6
2. PFXGP4501TADR/PFXGP4601TADR.....	7

Part Numbers and Functions

1. PFXGP4301TADR.....	8
2. PFXGP4401TADR.....	9
3. PFXGP4501TADR.....	10
4. PFXGP4601TADR.....	11
5. LED Indications.....	12

Interface

Serial Interface.....	14
-----------------------	----

Installation

1. Installation Method.....	17
2. Installation Requirements.....	18
3. Panel Cut Dimensions.....	20
4. Panel Type.....	24
5. Resin Boss Type.....	33

Wiring

Wiring.....	41
-------------	----

USB Cable Clamp

USB Cable Clamp.....	46
----------------------	----

Standards

Relevant Standards.....	48
-------------------------	----

Package Contents

The following items are included in the package. Before using the GP unit, please confirm that all items listed here are present:

- 1 GP unit: 1
- 2 DC power supply connector: 1 *1
- 3 USB cable clamp Type A: 1 set (1 clip and 1 tie)
- 4 Installation gasket: 1 set (8 per set)
- 5 Installation fasteners: 2 per set (attached to the top and bottom surfaces of the GP unit)
- 6 Installation screws: 4 per set (attached to the top and bottom surfaces of the GP unit)
- 7 GP4000 Series Rear Mount Model Installation Guide (this guide): 1
- 8 Warning/Caution Information: 1

1

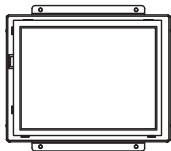

2

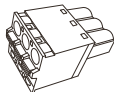
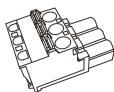
For
GP-4300/4400 SeriesFor
GP-4500/4600 Series

3

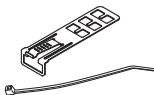

4

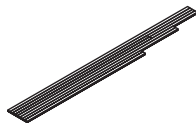

This unit has been carefully packed, with special attention to quality. However, should you find anything damaged or missing, please contact your local GP unit distributor immediately.

- *1 You can use the DC power connector for GP-4300/4400 series to supply power to GP-4500/4600 series. However the reverse is not possible. You cannot use the power connector for GP-4500/4600 series on GP-4300/4400 series.

About the Manual

This manual describes wiring and installation procedures. For more detailed information, refer to the GP4000 Series Hardware Manual.

You can download the manual from our website at
<http://www.pro-face.com/trans/en/manual/1001.html>

Global Code

A global code is assigned to every Pro-face product as a universal model number.

For more information on product models and their matching global codes, please refer to the following URL.

<http://www.pro-face.com/trans/en/manual/1003.html>

1. PFXGP4301TADR/PFXGP4401TADR

Specification		PFXGP4301TADR	PFXGP4401TADR
Power Supply	Rated Input Voltage	24 Vdc	
	Input Voltage Limits	19.2...28.8 Vdc	
	Voltage Drop	5 ms or less	
	Power Consumption	10.5 W or less	12 W or less
	When power is not supplied to external devices	6.5 W or less	8 W or less
	Backlight is OFF (Standby Mode)	4.5 W or less	5 W or less
	Backlight Dimmed (Brightness: 20 %)	5 W or less	5.5 W or less
In-Rush Current	30 A or less		
Voltage Endurance	1,000 Vac, 20 mA for 1 min. (between charging and FG terminals)		
Insulation Resistance	500 Vdc, 10M Ω or more (between charging and FG terminals)		

2. PFXGP4501TADR/PFXGP4601TADR

Power Supply	Rated Input Voltage	24 Vdc
	Input Voltage Limits	19.2...28.8 Vdc
	Voltage Drop	10 ms or less
	Power Consumption	17 W or less
	When power is not supplied to external devices	12 W or less
	Backlight OFF (Standby Mode)	7 W or less
	Backlight Dimmed (Brightness: 20%)	8 W or less
	In-Rush Current	30 A or less
Voltage Endurance		1,000 Vac, 20 mA for 1 min. (between charging and FG terminals)
Insulation Resistance		500 Vdc, 10 M Ω or more (between charging and FG terminals)

1. PFXGP4301TADR

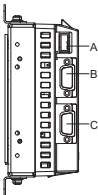
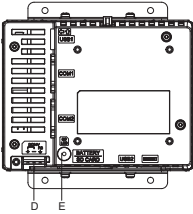
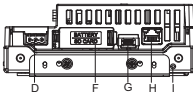
Right	
Rear	
Bottom	

- A: USB (Type A) Interface
- B: Serial Interface (COM1)
- C: Serial Interface (COM2)
- D: Power Plug Connector
- E: SD Card Access LED (see page.13)
- F: SD Card Interface Cover/Replacement Battery Insertion Cover
- G: USB (mini-B) Interface
- H: Ethernet Interface (see page.13)
- I: Maintenance LED (see page. 12)

2. PFXGP4401TADR

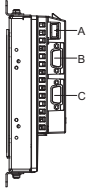
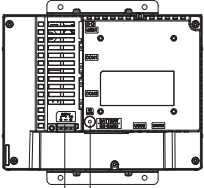
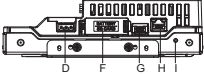
Right	 <p>A diagram showing the right side of the device. Three ports are labeled: A (USB Type A), B (Serial COM1), and C (Serial COM2).</p>
Rear	 <p>A diagram showing the rear of the device. Two connectors are labeled: D (Power Plug Connector) and E (SD Card Access LED).</p>
Bottom	 <p>A diagram showing the bottom of the device. Five connectors are labeled: D (Power Plug Connector), F (SD Card Interface Cover/Replacement Battery Insertion Cover), G (USB mini-B Interface), H (Ethernet Interface), and I (Maintenance LED).</p>

- A: USB (Type A) Interface
- B: Serial Interface (COM1)
- C: Serial Interface (COM2)
- D: Power Plug Connector
- E: SD Card Access LED (see page.13)
- F: SD Card Interface Cover/Replacement Battery Insertion Cover
- G: USB (mini-B) Interface
- H: Ethernet Interface (see page.13)
- I: Maintenance LED (see page.12)

3. PFXGP4501TADR

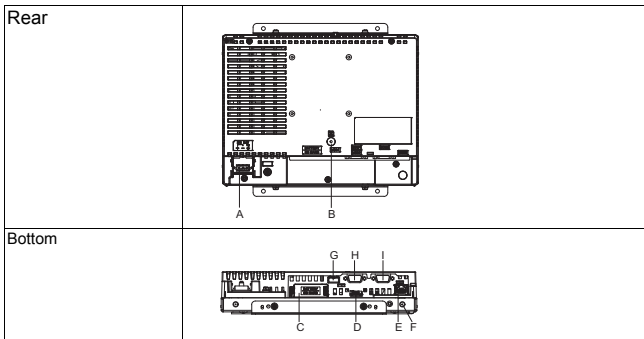

A: Power Plug Connector

B: SD Card Access LED (see page.13)

C: SD Card Interface Cover/Replacement Battery Insertion Cover

D: USB (mini-B) Interface

E: Ethernet Interface (see page.13)

F: Maintenance LED (see page.12)

G: USB (Type A) Interface

H: Serial Interface (COM1)

I: Serial Interface (COM2)

4. PFXGP4601TADR

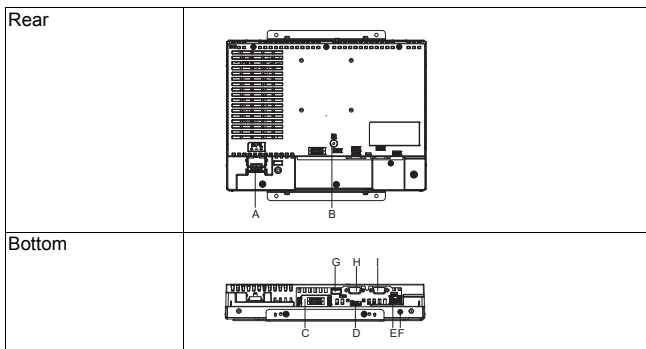

- A: Power Plug Connector
- B: SD Card Access LED (see page.13)
- C: SD Card Interface Cover/Replacement Battery Insertion Cover
- D: USB (mini-B) Interface
- E: Ethernet Interface (see page.13)
- F: Maintenance LED (see page.12)
- G: USB (Type A) Interface
- H: Serial Interface (COM1)
- I: Serial Interface (COM2)

5. LED Indications

(1) Maintenance LED

WARNING

UNINTENDED EQUIPMENT OPERATION

You cannot check the maintenance LED from the front of the GP unit.

- Design software by considering the possibility that touch operations may be performed while an error has occurred.
- To prevent malfunctions caused by touch operations, design software so that switches and other controls arranged on the screen do not function when you want the screen to be off even if these controls are accessed with touch operations. *1

Failure to follow these instructions can result in death, serious injury, or equipment damage.

*1 Refer to your screen editing software manual.

Color	Indicator	Operation Mode (Drawing)	Logic execution mode (when logic is enabled) ^{*1}
Green	ON	Offline	-
		In operation	RUN
	Flashing	In operation	STOP
Orange	Flashing	Software starting up	
Red	ON	Power is turned ON.	
	Flashing	In operation	Major Error
LED fade (Green) ^{*1}	ON	The GP unit's "Backlight Control" is set to Standby Mode and the screen has gone blank.	
-	OFF	Power is turned OFF.	

*1 Make sure your screen editing software supports the function.

(2) SD Card access LED

Color	Indicator	Description
Green (Active)	ON	The SD Card is inserted.
	OFF	The SD Card is not inserted or is not being accessed.

(3) Ethernet LED

	Color	Indicator	Description
	Green (Active)	Flashing	Data transmission is occurring.
		OFF	No data transmission
	Green (Link)	ON	Data transmission is available in 10BASE-T/100BASE-TX.
		OFF	No connection or subsequent transmission is NOT available.

Serial Interface

Note: For information on how to connect controllers and other types of equipment, refer to the corresponding device driver manual of your screen editing software.

DANGER

ELECTRIC SHOCK

The serial port is not isolated. The SG (signal ground) and the FG (frame ground) terminals are connected inside the unit. When using the SG terminal to connect an external device to the unit:

- Verify that a short-circuit loop is not created when you set up the system.
- Connect the #5 SG terminal to remote equipment when the host (PLC) unit is not isolated. Connect the #5 SG terminal to a known reliable ground connection to reduce the risk of damaging the RS-232C/RS422/RS485 circuit.

Failure to follow these instructions will result in death or serious injury.

CAUTION

LOSS OF COMMUNICATION

- All connections to the communication ports must not put excessive stress on the ports.
- Securely attach communication cables to the panel wall or cabinet.

Failure to follow these instructions can result in injury or equipment damage.

1. COM1

D-Sub 9 pin plug connector via an RS-232C cable.

Pin Number	RS-232C		
	Signal Name	Direction	Meaning
1	CD	Input	Carrier Detect
2	RD(RXD)	Input	Receive Data
3	SD(TXD)	Output	Send Data
4	ER(DTR)	Output	Data Terminal Ready
5	SG	–	Signal Ground
6	DR(DSR)	Input	Data Set Ready
7	RS(RTS)	Output	Request to Send
8	CS(CTS)	Input	Send Possible
9	CI(RI)/VCC	Input/–	Called Status Display +5 V±5 % Output 0.25 A* ¹
Shell	FG	–	Frame Ground (Common with SG)

*1 You can switch pin #9 between RI and VCC via software. To prevent damage or a unit malfunction, use only the rated current.

Interfit bracket is #4-40 (UNC).

Recommendations:

- Cable Connector: XM2D-0901 manufactured by OMRON Corporation.
- Cable Cover: XM2S-0913 manufactured by OMRON Corporation.
- Jack Screw (#4-40 UNC): XM2Z-0073 manufactured by OMRON Corporation.

2. COM2

D-Sub 9 pin plug connector via an RS-422/485 cable.

Pin Number	RS-422/RS-485		
	Signal Name	Direction	Meaning
1	RDA	Input	Receive Data A (+)
2	RDB	Input	Receive Data B (-)
3	SDA	Output	Send Data A (+)
4	ERA	Output	Data Terminal Ready A (+)
5	SG	-	Signal Ground
6	CSB	Input	Send Possible B (-)
7	SDB	Output	Send Data B (-)
8	CSA	Input	Send Possible A (+)
9	ERB	Output	Data Terminal Ready B (-)
Shell	FG	-	Frame Ground (Common with SG)

Interfit bracket is #4-40 (UNC).

Recommendations:

- Cable Connector: XM2D-0901 manufactured by OMRON Corporation.
- Cable Cover: XM2S-0913 manufactured by OMRON Corporation.
- Jack Screw (#4-40 UNC): XM2Z-0073 manufactured by OMRON Corporation.

1. Installation Method

Panel type	standard mount
	flat mount
Resin boss type	standard mount
	flat mount

Panel type: Weld the stud bolts to the panel, and then tighten the nuts to fasten the GP unit to the panel.

Resin boss type: Tighten the screws to attach the GP unit to the bosses of the resin boss-molded product.

Standard mount: The GP unit's screen is fixed within the inside of the panel or resin boss-molded product.

Flat mount: The GP unit's screen is fixed to the same surface of the panel or resin boss-molded product.

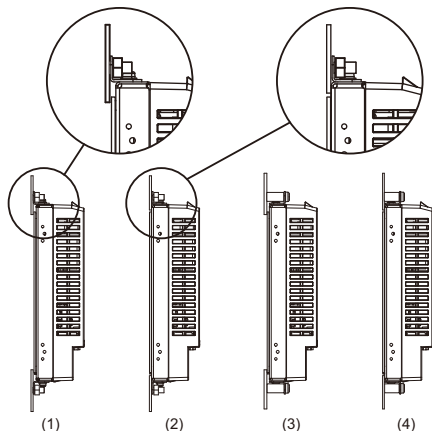

Installation diagrams (profile)

- 1) Panel type, standard mount
- 2) Panel type, flat mount
- 3) Resin boss type, standard mount
- 4) Resin boss type, flat mount

As shown in the figures, installation brackets can be attached at the top and bottom surfaces of the GP unit or on either side of the GP unit.

2. Installation Requirements

- Decide on the thickness of the enclosure wall, based on the level of strength required: For details, read chapter 3, "Panel Cut Dimensions" (see page 20).
- Even if panel thickness is within recommended range for "Panel Cut Dimensions", the panel could warp, depending on panel's material, size, and installation location of GP unit or other devices. To prevent panel warpage, the installation surface may need to be strengthened.
- Check that the installation panel or cabinet's surface is flat, in good condition and has no jagged edges.
- Be sure that the surrounding air temperature and the ambient humidity are within their designated ranges. Surrounding air temperature: 0 to 55 °C (32 to 131 °F)
ambient humidity: 10 to 90 %RH; wet bulb temperature: maximum 39 °C (102 °F).
When installing the GP unit in a cabinet or enclosure, the surrounding air temperature is the cabinet's or enclosure's internal temperature.

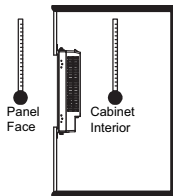

- Be sure that heat from surrounding equipment does not cause the GP unit to exceed its standard operating temperature.
- When installing the GP unit vertically, install the GP unit so that the power supply connector on the rear surface of the unit is at the top.

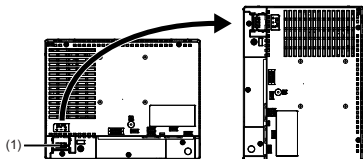

(1) Power Connector

- When installing the GP unit in a slanted position, the GP unit face should not incline more than 30 °.

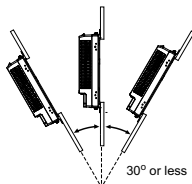

- When installing the GP unit in a slanted position with an incline more than 30 °, the ambient temperature must not exceed 40 °C (104 °F). You may need to use forced air cooling (fan, A/C) to ensure the ambient operating temperature is 40 °C or less (104 °F or less).
- For easier maintenance, operation and improved ventilation, install the GP unit at least 100 mm (3.94 in) away from adjacent structures and other equipment as shown in the following illustration.

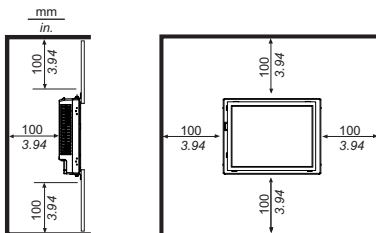

- The holes on the rear of the GP unit are not correspondent with VESA 75 mm standards. Do not attach the GP unit to the commercial-type VESA arm.

3. Panel Cut Dimensions

- Standard mount

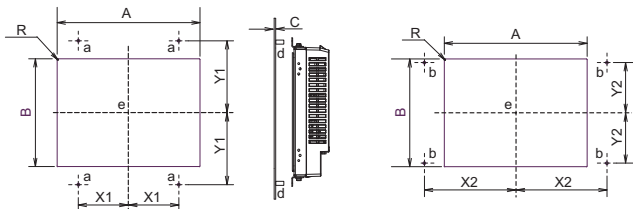

- Installation positions of stud bolts or positions of boss molds when attaching installation brackets at the top and bottom surfaces of the GP unit
- Installation positions of stud bolts or positions of boss molds when attaching installation brackets on either side of the GP unit
- 4-M4 x 10L stud bolts (no foreign material present on the base due to sparking or similar phenomena) or boss molds
- Center of the display area

	A	B	C		R
			Panel Type	Resin Boss Type	
PFXGP4301TADR	118.8 mm (+0.5, -0 mm) (4.68 in [+0.02, -0 in])	90 mm (+0.5, -0 mm) (3.54 in [+0.02, -0 in])	1.6 mm (0.06 in) to 3.2 mm (0.13 in)	2 mm (0.08 in) or more	1 mm (0.04 in) maximum
PFXGP4401TADR	155.3 mm (+0.5, -0 mm) (6.11 in [+0.02, -0 in])	117.4 mm (+0.5, -0 mm) (4.62 in [+0.02, -0 in])	SPCC (JIS G 3141) or SECC (JIS G 3313)		
PFXGP4501TADR	214.8 mm (+0.5, -0 mm) (8.46 in [+0.02, -0 in])	162 mm (+0.5, -0 mm) (6.38 in [+0.02, -0 in])	1.5 mm (0.06 in) to 6 mm (0.24 in)		
PFXGP4601TADR	249.6 mm (+0.5, -0 mm) (9.83 in [+0.02, -0 in])	188.1 mm (+0.5, -0 mm) (7.41 in [+0.02, -0 in])	SUS304 (JIS G 4305)		

Note : If you are designing the panel with a material other than sheet metal, ensure that the material has sufficient strength.

Unit mm [in]

	Attaching Installation Brackets on the Top and Bottom Surfaces of the GP Unit		Attaching Installation Brackets on the Sides of the GP Unit	
	X1	Y1	X2	Y2
PFXGP4301TADR	43 (±0.15) [1.69, (±0.01)]	69.5 (±0.15) [2.74, (±0.01)]	85.6 (±0.15) [3.37, (±0.01)]	43 (±0.15) [1.69, (±0.01)]
PFXGP4401TADR	43 (±0.15) [1.69, (±0.01)]	87.5 (±0.15) [3.45, (±0.01)]	109.8 (±0.15) [4.32, (±0.01)]	43 (±0.15) [1.69, (±0.01)]
PFXGP4501TADR	75.5 (±0.15) [2.97, (±0.01)]	108.55 (±0.15) [4.27, (±0.01)]	137.65 (±0.15) [5.42, (±0.01)]	75.5 (±0.15) [2.97, (±0.01)]
PFXGP4601TADR	75.5 (±0.15) [2.97, (±0.01)]	121.8 (±0.15) [4.80, (±0.01)]	158.8 (±0.15) [6.25, (±0.01)]	75.5 (±0.15) [2.97, (±0.01)]

Note : Note that the panel cut dimensions have been calculated with the display area, not the panel cut (A or B), as the reference.

Installation

• Flat mount

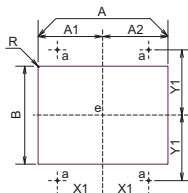

Rear panel (resin plate) surface

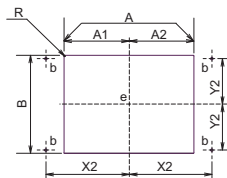
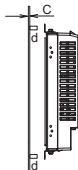

Rear panel (resin plate) surface

- Installation positions of stud bolts or positions of boss molds when attaching installation brackets at the top and bottom surfaces of the GP unit
- Installation positions of stud bolts or positions of boss molds when attaching installation brackets on either side of the GP unit
- 4-M4 x 10L stud bolts (no foreign material present on the base due to sparking or similar phenomena) or boss molds
- Center of the display area

	A		B	C		R
	A1	A2		Panel Type	Resin Boss Type	
PFXGP4301 TADR	143 mm (+0.5, -0 mm) (5.63 in [+0.02, -0 in])	72.5 mm (2.85 in [+0.01, -0 in])	109 mm (+0.5, -0 mm) (4.29 in [+0.02, -0 in])	1.6 mm (0.06 in) SPCC (JIS G 3141) or SECC(JIS G 3313)	2 mm (0.08 in) maximum	1 mm (0.04 in) maximum
	70.5 mm (+0.25, -0 mm) (2.78 in [+0.01, -0 in])	72.5 mm (+0.25, -0 mm) (2.85 in [+0.01, -0 in])				
PFXGP4401 TADR	174.5 mm (+0.5, -0 mm) (6.87 in [+0.02, -0 in])	88.2 mm (3.47 in [+0.01, -0 in])	134.2 mm (+0.5, -0 mm) (5.28 in [+0.02, -0 in])			
	86.3 mm (+0.25, -0 mm) (3.4 in [+0.01, -0 in])	88.2 mm (+0.25, -0 mm) (3.47 in [+0.01, -0 in])				
PFXGP4501 TADR	241 mm (+0.5, -0 mm) (9.49 in [+0.02, -0 in])	121.8 mm (4.8 in [+0.01, -0 in])	188 mm (+0.5, -0 mm) (7.4 in [+0.02, -0 in])			
	119.2 mm (+0.25, -0 mm) (4.69 in [+0.01, -0 in])	121.8 mm (+0.25, -0 mm) (4.8 in [+0.01, -0 in])				
PFXGP4601 TADR	289.4 mm (+0.5, -0 mm) (11.39 in [+0.02, -0 in])	147 mm (5.79 in [+0.01, -0 in])	214.4mm (+0.5, -0mm) (8.44in. [+0.02, -0in.]			
	142.4 mm (+0.25, -0 mm) (5.61 in [+0.01, -0 in])	147 mm (+0.25, -0 mm) (5.79 in [+0.01, -0 in])				

Note : If you are designing the panel with a material other than sheet metal, ensure that the material has sufficient strength.

	Attaching Installation Brackets on the Top and Bottom Surfaces of the GP Unit		Attaching Installation Brackets on the Sides of the GP Unit	
	X1	Y1	X2	Y2
PFXGP4301TADR	43 (±0.15) [1.69, (±0.01)]	69.5 (±0.15) [2.74, (±0.01)]	85.6 (±0.15) [3.37, (±0.01)]	43 (±0.15) [1.69, (±0.01)]
PFXGP4401TADR	43 (±0.15) [1.69, (±0.01)]	87.5 (±0.15) [3.45, (±0.01)]	109.8 (±0.15) [4.32, (±0.01)]	43 (±0.15) [1.69, (±0.01)]
PFXGP4501TADR	75.5 (±0.15) [2.97, (±0.01)]	108.55 (±0.15) [4.27, (±0.01)]	137.65 (±0.15) [5.42, (±0.01)]	75.5 (±0.15) [2.97, (±0.01)]
PFXGP4601TADR	75.5 (±0.15) [2.97, (±0.01)]	121.8 (±0.15) [4.80, (±0.01)]	158.8 (±0.15) [6.25, (±0.01)]	75.5 (±0.15) [2.97, (±0.01)]

Note: Note that the panel cut dimensions have been calculated with the display area, not the panel cut (A or B), as the reference.

4. Panel Type

NOTICE

PANEL UNSTEADY WHEN UNSECURED

Keep GP unit stabilized in the panel-cut while you are installing or removing the screw fasteners.

Failure to follow the instruction can result in equipment damage.

Installation procedure

Step	Procedure Details
1	<p data-bbox="218 170 936 282">Cut an opening in the panel to match the standard mount or flat mount panel cut dimensions, and then weld four M4 x 10L stud bolts perpendicular to the rear surface of the panel in order to fix the GP unit in place.</p> <p data-bbox="218 286 936 311">Note :</p> <ul data-bbox="218 315 936 423" style="list-style-type: none"> <li data-bbox="218 315 936 365">• Before you start this work, carefully read "3. Panel Cut Dimensions" (see page 20). <li data-bbox="218 369 936 394">• Prepare four stud bolts and four nuts within your quality assurance range. <li data-bbox="218 398 936 423">• The stud bolt height is 10 mm (0.39 in). <div data-bbox="218 428 828 859"> <p data-bbox="233 428 414 473">10 0.39 $\frac{mm}{in.}$</p> <p data-bbox="233 864 533 889">Installation diagram (profile)</p> </div> <ul data-bbox="218 927 936 952" style="list-style-type: none"> <li data-bbox="218 927 936 952">• We recommend that you use M4 nuts (ISO4032, JIS B 1181). <div data-bbox="218 962 476 1263"> <p data-bbox="218 962 476 1113">8.1 0.32 $\frac{mm}{in.}$</p> <p data-bbox="305 1077 378 1113">7 0.28</p> <p data-bbox="305 1157 461 1263">3.2 0.13</p> </div>

2

Attach the installation gaskets to the panel.
Installation gaskets are included for the standard mount orientation and for the flat mount orientation.

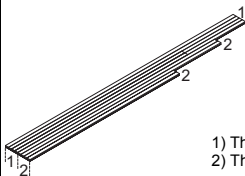

- 1) The installation gaskets for Flat mount
2) The installation gaskets for Standard mount

Peel off the removable paper layer, and then attach the adhesive surface to the rear surface of the panel as shown in the figure. Follow the cross-section of the panel cut and attach the adhesive surface on top of the installation gasket so that the adhesive surface sticks out by approximately 3 mm (0.12 in) past its adjacent adhesive surface.

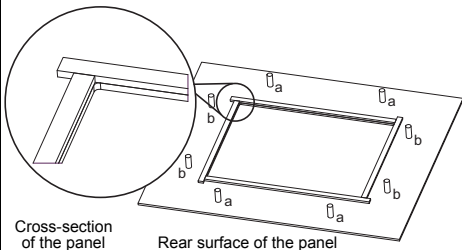

Cross-section
of the panel

Rear surface of the panel

- a) Stud bolts when attaching installation brackets at the top and bottom surfaces of the GP unit
b) Stud bolts when attaching installation brackets on either side of the GP unit

Note :

- Be sure to use the included installation gaskets.
- Due to the installation gasket properties, do not pull on the installation gaskets while you attach them. Doing so may cause the installation gaskets to be embedded in the installation brackets.
- If the installation gaskets are used for a long time, the gaskets may be damaged or dirt may affix to the gaskets, which may cause their effectiveness to decrease. Replace the installation gaskets periodically.

3

Slowly peel the protective sheet off of the GP unit's screen.

Note : Peeling off the protective sheet with excessive force may peel off the film of the touch panel.

4	<p>When the GP unit is shipped from the factory, installation brackets are fixed to its top surface and bottom surface. This corresponds to the standard mount orientation. If you are installing the GP unit in a panel with the GP unit in the same state as when it was shipped from the factory, read step 8.</p> <p>If you are switching the installation brackets to their positions on the sides of the GP unit or if you are installing the GP unit with the flat mount orientation, read steps 5 to 7.</p>
5	<p>[Switching the installation brackets to their positions on the sides of the GP unit or changing to the flat mount orientation]</p> <p>Orient the GP unit so that its screen faces down, and then place the GP unit on a clean and level surface.</p>
6	<p>Use a Phillips head screwdriver to remove the two installation screws fixing the one installation bracket in place on the top surface of the GP unit. In the same manner, remove the one installation bracket from the bottom surface.</p>

7

Attach the installation brackets to the top and bottom surfaces of the GP unit or to the sides of the GP unit. In each case, attach the surface of the installation bracket that has six open holes to the GP unit. Note that the protruding parts and the fixation positions of installation screws vary between the standard mount (figure A) and flat mount (figure B) orientations. Use a Phillips head screwdriver to fix in place two installation screws per installation bracket. The tightening torque is 0.8 N•m (7.1 lb-in).

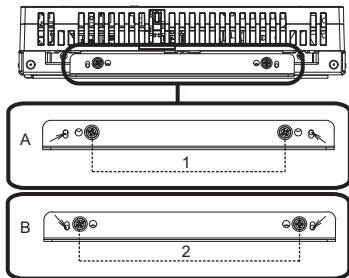

A) Standard mount

- 1) Use two installation screws to fix the bracket in place. (Use the two inner holes.)

B) Flat mount

- 2) Use two installation screws to fix the bracket in place. (Use the two outer holes.)

Note : Check the positions of the protruding parts. Depending on the installation method, the positions of these parts may differ from the positions indicated by the arrows in the figure.

- 8 When you are installing the GP unit horizontally, hold the GP unit so that the arrow pointing in the horizontal direction on the rear surface of the GP unit points up as shown in the figure.

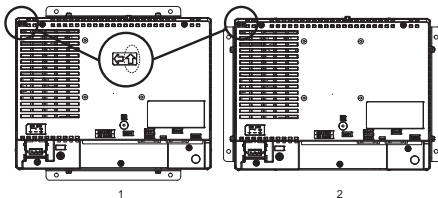

- 1) Figure of the GP unit's rear surface when attaching installation brackets at the top and bottom surfaces of the GP unit
- 2) Figure of the GP unit's rear surface when attaching installation brackets on either side of the GP unit

- 9 Insert the GP unit through the rear surface of the panel, pass the stud bolts through the four installation bracket holes, and then tighten nuts on the stud bolts to fix the GP unit in place. The tightening torque is 0.8 to 1.0 N•m (7.1 to 8.9 lb-in).

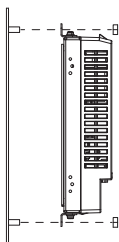

Installation diagram (profile)

10

When installing the GP unit with the flat mount orientation, affix the Overlay to the front of the GP unit.

In advance, align the four corners of the Overlay outline on the panel as shown in the figure, and then mark these corners. Peel off the removable paper layer from the Overlay, align the Overlay with the four marks, and then affix the Overlay to the panel.

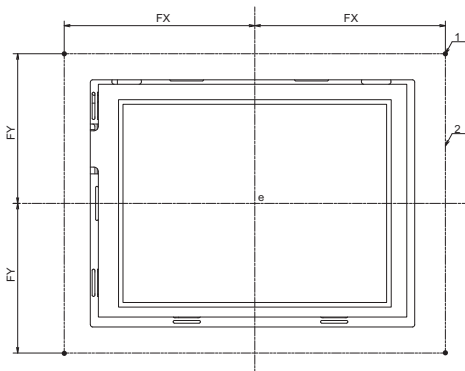

- 1) Locations to mark (four locations)
- 2) Overlay outline
- e) Display area

mm (in)
(dimension tolerance: ± 0.2 mm [± 0.01 in])

	FX	FY
PFXGP4301TADR	84.0 (3.31)	66.0 (2.60)
PFXGP4401TADR	99.7 (3.93)	78.6 (3.09)
PFXGP4501TADR	133.3 (5.25)	105.5 (4.15)
PFXGP4601TADR	158.5 (6.24)	118.7 (4.67)

Note : Use the Overlay manufactured by Pro-face. Use one of the following models.

- PFXZGPF6W1 (for the PFXGP4301TADR)
- PFXZGPF7W1 (for the PFXGP4401TADR)
- PFXZGPF10W1 (for the PFXGP4501TADR)
- PFXZGPF12W1 (for the PFXGP4601TADR)

NOTICE

BROKEN ENCLOSURE

- Attach correctly without a crevice between gaskets and between gasket and the panel.
- Do not attach installation fastener in a different position from mounting instruction.
- Do not exert more than 0.8 N•m (7.1 lb-in) of torque when tightening the installation screws.
- For use on a flat surface of a Type 1 Enclosure
- Attach the Overlay correctly with the installation.
- Do not reuse the Overlay removed once.

Failure to follow these instructions can result in equipment damage.

Removal procedure

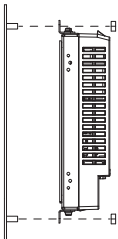
Step	Procedure Details
1	<p>Remove the nuts from the four stud bolts fixed in place on the rear surface of the panel, and then slowly remove the GP unit from the panel.</p>  <p style="text-align: right;">Removal diagram (profile)</p>

CAUTION

RISK OF INJURY

Be careful of the glass of the front of the GP unit.

- Wear gloves when you are installing the GP unit.
- Do not push the LCD panel strongly.
- When installing the GP unit with the flat mount orientation, affix the Overlay to the front of the GP unit.

Do not drop the GP unit when you remove it from the panel.

- Hold the GP unit in place after removing the fasteners.
- Use both hands.

Failure to follow the instruction can result in injury or equipment damage.

5. Resin Boss Type

NOTICE

PANEL UNSTEADY WHEN UNSECURED

Keep GP unit stabilized in the panel-cut while you are installing or removing the screw fasteners.

Failure to follow the instruction can result in equipment damage.

Installation procedure

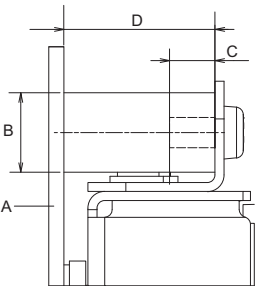
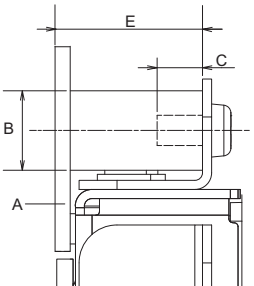
Step	Procedure Details
1	<p>Follow the standard mount or flat mount panel cut dimensions to perform sufficient tests in advance with designs that meet the following conditions, confirm the safety of the system, and then mold the resin plate.</p> <div style="display: flex; justify-content: space-around; align-items: flex-end;"> <div style="text-align: center;">  <p>Standard mount</p> </div> <div style="text-align: center;">  <p>Flat mount</p> </div> </div>

- A) Resin plate
 B) Boss diameter: $\varnothing 10.5 \text{ mm} \pm 0.5 \text{ mm}$ ($\varnothing 0.41 \text{ in} \pm 0.02 \text{ in}$)
 C) Lower hole depth: 6 mm (0.24 in) or more
 D) Boss height: 20 mm (0.79 in) $\pm 0.1 \text{ mm}$ ($\pm 0 \text{ in}$) for the standard mount orientation
 E) Boss height and resin plate thickness*¹):
 19.5 mm (0.77 in) $\pm 0.1 \text{ mm}$ ($\pm 0 \text{ in}$) for the flat mount orientation
 *1 Resin plate thickness: max. 2 mm (0.08 in)

Note :

- Before you start this work, carefully read "3. Panel Cut Dimensions" (see page 20).
- Design the resin plate on the basis of sufficient testing and within your quality assurance range. However, the boss height cannot be changed.
- Do not construct any ribs outside of the area indicated by diagonal lines in the figure.

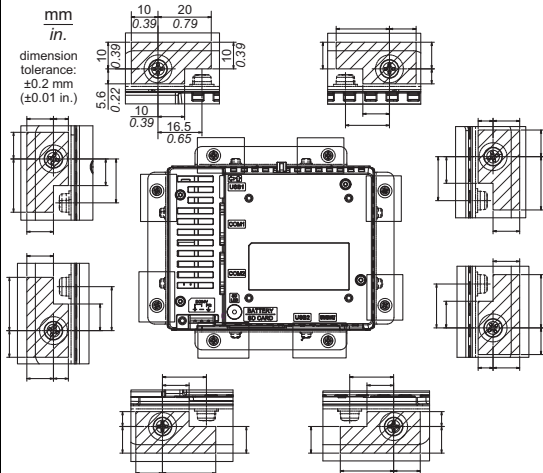

(This figure shows PFXGP4301TADR. The dimensions are common with all of the rear mount models.)

2

Attach the installation gaskets to the panel. Installation gaskets are included for the standard mount orientation and for the flat mount orientation.

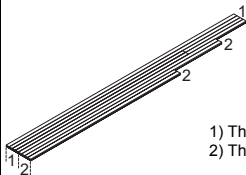

- 1) The installation gaskets for Flat mount
2) The installation gaskets for Standard mount

Peel off the removable paper layer, and then attach the adhesive surface to the rear surface of the resin plate as shown in the figure. Follow the cross-section of the panel cut and attach the adhesive surface on top of the installation gasket so that the adhesive surface sticks out by approximately 3 mm (0.12 in) past its adjacent adhesive surface.

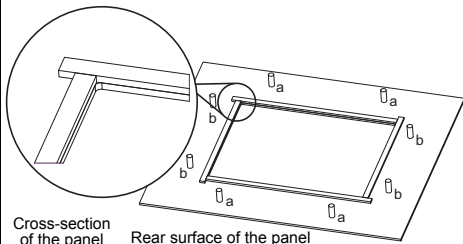

Cross-section
of the panel

Rear surface of the panel

- a) Boss when attaching installation brackets at the top and bottom surfaces of the GP unit
b) Boss when attaching installation brackets on either side of the GP unit

Note :

- Be sure to use the included installation gaskets.
- Due to the installation gasket properties, do not pull on the installation gaskets while you attach them. Doing so may cause the installation gaskets to be embedded in the installation brackets.
- If the installation gaskets are used for a long time, the gaskets may be damaged or dirt may affix to the gaskets, which may cause their effectiveness to decrease. Replace the installation gaskets periodically.

3	<p>Slowly peel the protective sheet off of the GP unit's screen.</p> <p>Note : Peeling off the protective sheet with excessive force may peel off the film of the touch panel.</p>
4	<p>When the GP unit is shipped from the factory, installation brackets are fixed to its top surface and bottom surface.</p> <p>These installation brackets are fixed in positions that do not match the resin boss type, so follow the procedure below to change the positions in which the installation brackets are attached.</p>
5	<p>Orient the GP unit so that its screen faces down, and then place the GP unit on a clean and level surface.</p>
6	<p>Use a Phillips head screwdriver to remove the two installation screws fixing the one installation bracket in place on the top surface of the GP unit. In the same manner, remove the one installation bracket from the bottom surface.</p>
7	<p>Attach the installation brackets to the top and bottom surfaces of the GP unit or to the sides of the GP unit. In each case, attach the surface of the installation bracket that has six open holes to the GP unit as shown. Use a Phillips head screwdriver to fix in place two installation screws per installation bracket. The tightening torque is 0.8 N•m (7.1 lb-in).</p> <div data-bbox="350 710 785 952" data-label="Image"> </div> <p>1) Use two installation screws to fix the bracket in place. (Use the two inner holes.)</p>

- 8 When you are installing the GP unit horizontally, hold the GP unit so that the arrow pointing in the horizontal direction on the rear surface of the GP unit points up as shown in the figure.

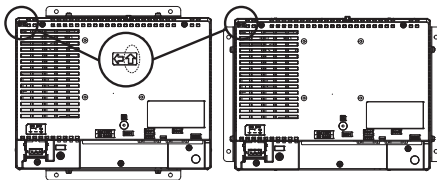

- 1) Figure of the GP unit's rear surface when attaching installation brackets at the top and bottom surfaces of the GP unit
- 2) Figure of the GP unit's rear surface when attaching installation brackets on either side of the GP unit

- 9 Insert the GP unit through the rear surface of the resin plate, pass the bosses through the four installation bracket holes, and then tighten the screws to fix the GP unit in place. We recommend that you use M4 screws. The tightening torque is $0.8 \text{ N}\cdot\text{m}$ (7.1 lb-in).



Installation diagram (profile)

10

When installing the GP unit with the flat mount orientation, affix the Overlay to the front of the GP unit.

In advance, align the four corners of the Overlay outline on the panel as shown in the figure, and then mark these corners. Peel off the removable paper layer from the Overlay, align the Overlay with the four marks, and then affix the Overlay to the panel.

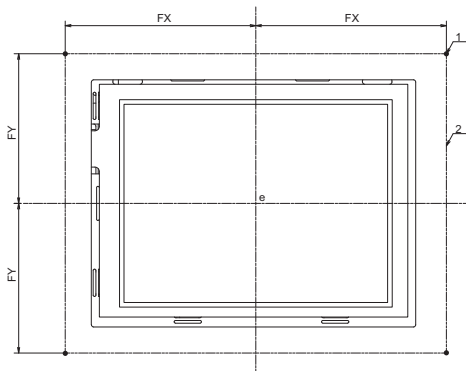

- 1) Locations to mark (four locations)
- 2) Overlay outline
- e) Display area

mm (in)
(dimension tolerance: ± 0.2 mm [± 0.01 in])

	FX	FY
PFXGP4301TADR	84.0 (3.31)	66.0 (2.60)
PFXGP4401TADR	99.7 (3.93)	78.6 (3.09)
PFXGP4501TADR	133.3 (5.25)	105.5 (4.15)
PFXGP4601TADR	158.5 (6.24)	118.7 (4.67)

Note : Use the Overlay manufactured by Pro-face. Use one of the following models.

- PFXZGPFSR6W1 (for the PFXGP4301TADR)
- PFXZGPFSR7W1 (for the PFXGP4401TADR)
- PFXZGPFSR10W1 (for the PFXGP4501TADR)
- PFXZGPFSR12W1 (for the PFXGP4601TADR)

NOTICE

BROKEN ENCLOSURE

- Attach the Overlay correctly with the installation.
- Do not reuse the Overlay removed once.
- Do not exert more than 0.8 N•m (7.1 lb-in) of torque when tightening the installation screws.
- For use on a flat surface of a Type 1 Enclosure
- Attach correctly without a crevice between gaskets and between gasket and the panel.
- Do not attach installation fastener in a different position from mounting instruction.

Failure to follow these instructions can result in equipment damage.

Removal procedure

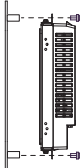
Step	Procedure Details
1	<p>Remove the screws from the four bosses fixed in place on the rear surface of the resin plate, and then slowly remove the GP unit from the resin plate.</p>  <p>Removal diagram (profile)</p>

⚠ CAUTION**RISK OF INJURY**

Be careful of the glass of the front of the GP unit.

- Wear gloves when you are installing the GP unit.
- Do not push the LCD panel strongly.
- When installing the GP unit with the flat mount orientation, affix the Overlay to the front of the GP unit.

Do not drop the GP unit when you remove it from the panel.

- Hold the GP unit in place after removing the fasteners.
- Use both hands.

Failure to follow the instruction can result in injury or equipment damage.

Wiring

WARNING

HAZARD OF ELECTRIC SHOCK, EXPLOSION OR ARC FLASH

- Remove all power from the device before removing any elements of the system, and prior to installing or removing any accessories, hardware, or cables.
- Remove power before wiring the GP unit's power terminals.
- The DC model uses only 24 Vdc power. Using any other level of power can damage both the power supply and the GP unit.
- Since the GP unit is not equipped with a power switch, be sure to connect a power switch to the power supply.
- Be sure to ground the GP unit's FG terminal.
- Replace and secure all elements of the system before applying power to the GP unit.

Failure to follow these instructions can result in death, serious injury, or equipment damage.

Note:

- The shield ground (SG) and FG terminals are connected internally in the GP unit.
- When the functional ground (FG) terminal is connected, be sure the wire is grounded. Not grounding the GP unit can result in excessive Electromagnetic Interference (EMI). Grounding is required to meet EMC level immunity.

1. Connecting the DC Power Cord

Field wiring terminal marking for wire type (75 °C (167 °F) Copper conductors only)

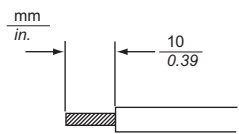
Power Cord Diameter	0.75 to 2.5 mm ² (18-13 AWG)
Conductor type	Simple or Stranded Wire*1
Conductor length	

*1 If the conductor's end (individual) wires are not twisted correctly, the end wires may either short against each other or against an electrode.

Power Connector Specifications: Spring Clamp Terminal Blocks

PFXGP4301TADR
PFXGP4401TADR

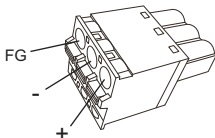

PFXGP4501TADR
PFXGP4601TADR

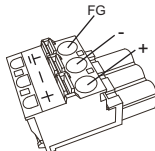

Connection	Wire
+	24 Vdc
-	0 Vdc
FG	Grounded terminal connected to the panel chassis.

Note: The DC power supply connector (plug) for PFXGP4301TADR/PFXGP4401TADR is PFXZCBCNDC1 (manufactured by Pro-face). The DC power supply connector (plug) for PFXGP4501TADR/PFXGP4601TADR is PFXZCBCNDC2 (manufactured by Pro-face).

Recommended Driver	SZS 0.6x3.5 (1205053)
Recommended Pin Terminals	3201288 AI 0,75-10 GY 3200182 AI 1 -10 RD 3200195 AI 1,5 -10 BK 3202533 AI 2,5 -10 BU
Recommended Pin Terminal Crimp Tool	CRIMPFOX 6

(Items are made by Phoenix Contact.)

How to connect the DC Power Cord

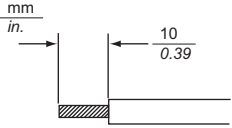
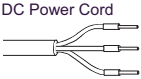
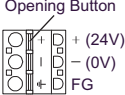
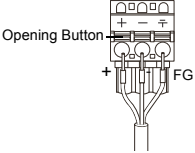
Step	Action
1	Confirm the power cord is not connected to the power supply.
2	Check the rated voltage, and remove the "DC24V" sticker on the DC power supply connector.
3	Remove 10 mm (0.39 in) of the vinyl membrane off the ends of the power cord wires. 
4	If using stranded wire, twist the ends. Tinning the ends with solder reduces risk of fraying and ensures good electrical transfer.
5	Push the Opening button with a small and flat screwdriver to open the desired pin hole.
6	Insert each pin terminal into its corresponding holder. Release the Opening button to clamp the pin in place. <div style="display: flex; justify-content: space-around; align-items: flex-start;"> <div style="text-align: center;"> <p>PFXGP4301TADR PFXGP4401TADR</p>  </div> <div style="text-align: center;"> <p>Opening Button</p>  </div> <div style="text-align: center;"> <p>PFXGP4501TADR PFXGP4601TADR</p>  </div> </div>
7	After inserting all three pins, insert the DC power supply connector into the power connector on the GP unit.

Note:

- Do not solder the wire directly to the power receptacle pin.
- To prevent the possibility of a terminal short, use a pin terminal that has an insulating sleeve.
- The DC power supply connector for PFXGP4301TADR/PFXGP4401TADR can be connected to PFXGP4501TADR/PFXGP4601TADR. However, the DC power supply connector for PFXGP4501TADR/PFXGP4601TADR is unable to connect to PFXGP4301TADR/PFXGP4401TADR.

2. Wiring Cautions

Improving Noise/Surge Resistance

- The GP unit's power supply cord should not be bundled with or kept close to main circuit lines (high voltage, high current), power lines, or input/output lines, and their various systems should be kept separate. When power lines cannot be wired via a separate system, use shielded cables for input/output lines.
- Make the power cord as short as possible, and be sure to twist the ends of the wires together (i.e. twisted pair cabling) from close to the power supply unit.
- If there is an excess amount of noise on the power supply line, connect a noise reducing transistor before turning on the power.
- Connect a surge absorber to handle power surges. Be sure to ground the surge absorber (E1) separately from the GP unit (E2).

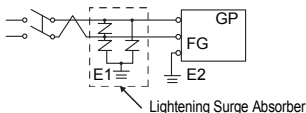

Short Circuit Prevention

- The SG (signal ground) and FG (functional ground) terminals are connected internally in the GP unit. When connecting the SG line to another device, be sure that no shorting loops are formed.

Grounding

- Use an exclusive grounding wire with a grounding resistance of $100\ \Omega$ or less and a wire of $2\ \text{mm}^2$ (AWG 14) or thicker, or your country's applicable standard.

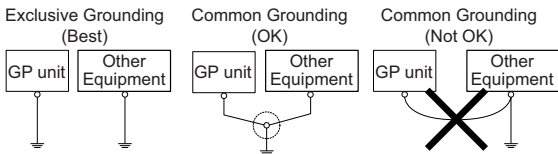

USB Cable Clamp

When using a USB device, attach a USB cable clamp to the USB interface to prevent the USB cable from being disconnected.

WARNING

RECOMMENDATION FOR RESTRICTED AREAS

- Verify the power, input, and output (I/O) wiring are in accordance with Class I, Division 2 wiring methods.
- Substitution of any component may impair suitability for Class I, Division 2.
- Confirm that the USB cable has been fixed with the USB cable clamp before using the USB interface.
- Remove power before attaching or detaching any connectors to or from the unit.

Failure to follow these instructions can result in death, serious injury, or equipment damage.

1. Attaching the USB Cable Clamp

Note: Watch your fingers. The edge of the clip is sharp.

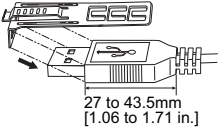
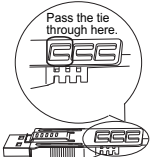
Step	Action
1	<p>Mount the clip to the USB mark  connector shell so that it overlaps. The clip matches the 27 to 43.5 mm [1.06 to 1.71 in] length of the USB connector.</p> 
2	<p>Align the clip and the USB cable connector shell. Adjust the position of the holes where the clip is attached. To ensure stability, select the clip-hole position that is closest to the base of the connector shell.</p> 

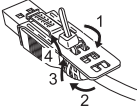
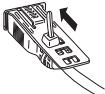
3	<p>As shown, pass the tie through the clip hole. Next, turn the tie and pass it through the head so that the USB cable can pass through the center of the tie loop. The clip is now attached to the USB cable.</p>  <p>Note:</p> <ul style="list-style-type: none"> • Check the direction of the head beforehand. Make sure the USB cable is through the center of the tie loop and that the tie can pass through the head. • You can substitute the tie provided with PFXZCBCLUSA1 (manufactured by Pro-face) or other commercially available ties with a width of 4.8 mm [0.19 in] and thickness of 1.3 mm [0.05 in].
4	<p>While pressing the grip on the clip, insert the cable from step 3 all the way into the USB host interface. Make sure that the clip tab is secured to the USB cable attached to the GP unit.</p> 

2. Removing the USB Cable

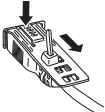
Step	Action
1	<p>Remove the USB cable while pushing the grip section of the clip.</p> 

Relevant Standards

For information on certifications and standards, such as certified models and certificates, see the product markings or the following URL:

<http://www.pro-face.com/trans/en/manual/1002.html>

	Names	Registration Model No.
GP-4300 Series	GP-4301T	PFXGP4301TADR
GP-4400 Series	GP-4401T	PFXGP4401TADR
GP-4500 Series	GP-4501T (Analog Touch Panel)	PFXGP4501TADR
GP-4600 Series	GP-4601T (Analog Touch Panel)	PFXGP4601TADR

The GP unit is manufactured in accordance with:

- Standard UL 508 and CSA C22.2 n°142 for Industrial Control Equipment

Note:

- For use in Pollution Degree 2 environments.
- For use on a flat surface of a Type 1 Enclosure.
- 24V DC input unit must be used with a Class 2 power supply.

WARNING

RECOMMENDATION FOR RESTRICTED AREAS

- Verify the power, input, and output (I/O) wiring are in accordance with Class I, Division 2 wiring methods.
- Substitution of any component may impair suitability for Class I, Division 2.
- Do not disconnect equipment while the circuit is live or unless the area is known to be free of Ignitable concentrations.
- Securely lock externally connected units and each interface before turning on the power supply.
- The USB (mini-B) interface is for temporary connection only during maintenance and setup of the device. Do not use, connect, or disconnect USB (mini-B) cable unless area is known to be non-hazardous.
- Potential electrostatic charging hazard: wipe the front panel of the terminal with a damp cloth before turning ON.

Failure to follow these instructions can result in death, serious injury, or equipment damage.

CAUTION

ENVIRONMENTAL HAZARDS TO THE EQUIPMENT

- Allow the device to reach the surrounding air temperature, not exceeding 55 °C (131 °F), before turning the device on:
- Do not turn on the device if condensation has occurred inside the device. After it is completely dry again, the device may be turned on.
- Do not expose the device to direct sunlight.
- Do not obstruct the vents in the device casing.
- Remove any dust from the device before turning it on.
- Ensure that the cable installation fasteners are not damaged. Replace them, if necessary.
- Only qualified personnel can change the primary battery.

Failure to follow these instructions can result in injury or equipment damage.

Inquiry

Do you have any questions about difficulties with your GP?

Please access our site anytime that you need help with a solution.

<http://www.pro-face.com/trans/en/manual/1001.html>

Notes

Please be aware that Digital Electronics Corporation shall not be held liable by the user for any damages, losses, or third party claims arising from the uses of this product.

中国 RoHS 相关资料

(本资料是中国 RoHS 的必备资料。)(This information is essential for China RoHS.)

部件名称 Part Name	有害物质 Hazardous Substances					
	铅 (Pb)	汞 (Hg)	镉 (Cd)	六价铬 (Cr (VI))	多溴联苯 (PBB)	多溴二苯醚 (PBDE)
金属部件 Metal parts	○	○	○	○	○	○
塑料部件 Plastic parts	○	○	○	○	○	○
电子件 Electronic	×	○	○	○	○	○
触点 Contacts	○	○	○	○	○	○
线缆和线缆附件 Cables & cabling accessories	○	○	○	○	○	○

本表格依据 SJ/T 11364 的规定编制。

○：表示该有害物质在该部件所有均质材料中的含量均在 GB/T 26572 规定的限量要求以下。

×：表示该有害物质至少在该部件的某一均质材料中的含量超出 GB/T 26572 规定的限量要求。

This table is made according to SJ/T 11364.

○：Indicates that the concentration of hazardous substance in all of the homogeneous materials for this part is below the limit as stipulated in GB/T 26572.

×：Indicates that concentration of hazardous substance in at least one of the homogeneous materials used for this part is above the limit as stipulated in GB/T 26572.